

Controlling pocket gopher damage to agricultural crops

W.D. Edge and J.P. Loegering

Pocket gophers cause considerable damage to hay and grain crops as well as to cherry, apple, pear, and filbert orchards. Some of the losses are a direct result of feeding activities of gophers: root-clipping apple and cherry trees, eating alfalfa hay and filbert nuts. Other losses result from tunneling and mound-building activities: soil and rocks from mounds damage harvesting machinery and degrade quality of crops. This publication describes activities designed to reduce damages by pocket gophers to hay, grain, and orchard crops.

Although pocket gophers also are a serious problem to homeowners and gardeners, damage to hay, grain, and orchards usually occurs over larger acreages, calling for control methods that differ from those used by the homeowner and gardener.

Although damage is the focus of this publication, it is noteworthy that pocket gophers can be an important part of an agricultural system. They provide many beneficial functions and may improve soils, thereby enhancing crop growth. Their burrowing activity mixes and aerates the soil, bringing fresh minerals to the surface and permitting deeper penetration of water.

Gophers also are an important component of ecosystems, affecting both the character of the vegetation and many small mammals and birds. For example, many animals, such as hawks, owls, foxes, coyotes, badgers, weasels, and snakes, rely on gophers as prey and are affected by their absence.

Identify the pest

As with any control program, the first step is to ensure that the pest is identified properly. Damages by other pests such as moles and mice may approximate those of gophers, but control methods for these pests are

different and are inappropriate for pocket gophers. Because the mole also is a burrower and mound builder, it's easy to misidentify the pest.

Pocket gophers extend lateral (side) tunnels to the surface from their deeper main tunnels and push out the excess soil in flattened or fan-shaped mounds. These range from 12 to 24 inches in diameter and 4 or more inches in height. Gophers then plug the surface opening through which this soil is pushed, leaving a noticeable dent or plug at one end of the pile (Figure 1). The entire lateral may be backfilled to the main tunnel.

Moles. Mounds are the result of repeated eruptions from below and simply continue to grow or enlarge until the mole has disposed of the excess soil and moved on. Mole mounds are higher and generally rounder in shape than gopher mounds and look more like miniature volcanoes.

No hole at the side of the mound is evident. However, if you place your finger in the middle of the mound and push it down in a circular fashion, you'll discover the mole's hole is in the middle rather than on the edge of the mound.

The pattern of mounds helps to distinguish gopher from mole activity. Gopher mounds tend to be clumped in tight groups; the mole's tend to be spaced in a line as single mounds (Figure 2).

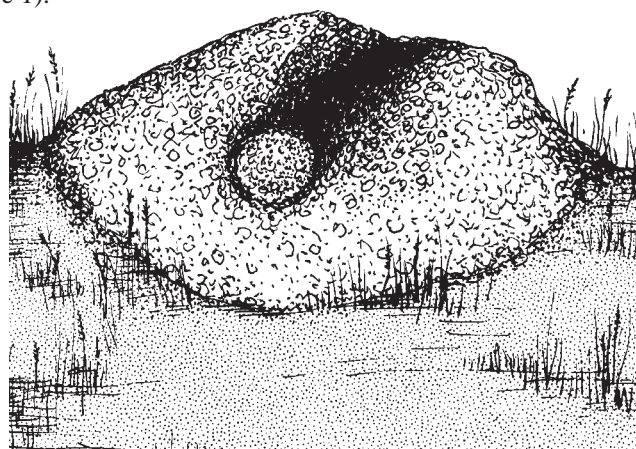

Figure 1.—Pocket gopher mound.

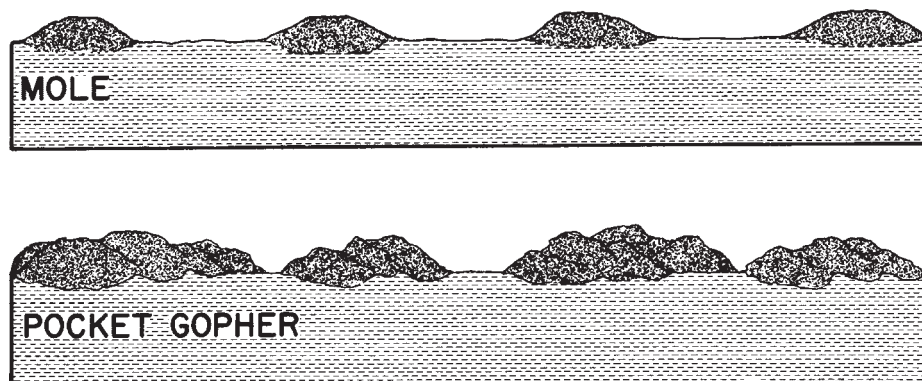

Figure 2.—Mound patterns, mole and pocket gopher.

W. Daniel Edge, Extension wildlife specialist, and John P. Loegering, instructor in fisheries and wildlife, both of Oregon State University, prepared this revision. The original author was David S. deCalesta, former Extension wildlife specialist, Oregon State University.

Meadow mice (voles) are another pest commonly confused with the pocket gopher. These small animals girdle the base of cherry and apple trees, often killing the trees.

A good clue is the presence of small tunnel systems at or just below the surface of the ground in the shelter of grass or weedy cover. Meadow mice do not produce mounds at the entrance of their open burrows, which are about the size of a 50¢ piece. Tooth marks of voles are very small and leave a fuzzy appearance on the bark of damaged trees.

Pocket gophers may girdle but more often tend to clip off roots and rootlets. When the root system of damaged trees is exposed, the loss of roots and rootlets is very typical (Figure 3).

Voies may use pocket gopher burrow systems but may make their own excavations as well. Any area with pocket gopher burrows and mounds that also has small open holes with interconnecting surface tunnels can be suspected of harboring both voles and pocket gophers.

Tree squirrels have been known to strip bark from the base of filbert and other orchard trees. This type of damage is totally different from that caused by pocket gophers or voles, so there should be little confusion. Also, there are no burrow openings or mounds; tree squirrels make their homes in hollow openings in trees as well as in large, bulky leaf nests. Almost always there is an adjacent hardwood woodlot from which squirrels forage.



Figure 3.—Root damage by pocket gophers.

Other species, such as porcupines, cottontail, and jackrabbits, also girdle fruit, nut, and ornamental trees. However, their damage is usually quite extensive around the base of trees. Pocket gopher damage is much lower on the tree.

Legal status

Pocket gophers are classified as nongame wildlife under the Oregon Wildlife Codes, and they're not afforded any specific protection. Furthermore, the wildlife codes permit a landowner or agent to control noxious animals on his or her property. Pocket gophers in Oregon are not protected under Federal regulations.

Control methods

Flood irrigation. Years ago, farmers flooded hay and grain crops requiring irrigation with a thin sheet of water in spring and at intervals throughout early summer. This forced pocket gophers to leave their burrow systems or drown—and resulted in nearly 100 percent control. Invasion from adjacent nonirrigated lands or reinvasion by animals forced to nearby higher ground often was a problem.

The advent of sprinkler irrigation increased acreages where irrigated crops could be grown, such as on hillsides and uneven lands, but pocket gophers aren't flooded out under sprinkler irrigation, so this form of cheap control isn't generally available.

In situations where you can use flood irrigation and pocket gophers are a serious problem, consider this method but give careful attention to control in surrounding areas, to prevent reinvasion.

Vegetation management. Pocket gopher damages can be reduced by about 50 percent by applying herbicides that remove vegetation pocket gophers require for food. This option is limited to orchards and to noncrop areas close to hay and grain crops.

Removing existing crops (such as alfalfa), followed by deep tilling, disrupts burrow systems, removes food, and results in a significant reduction in pocket gopher numbers in fields so treated.

When alfalfa fields begin to decline in productivity for one reason or another, plow them and plant some alternate crop rather than keep them in

alfalfa for a few additional years at greatly reduced yields.

Trapping. Techniques for trapping pocket gophers are outlined in EC 1255. In situations where infestations are limited to 5 or fewer acres, trapping might be an option. Trapping as a followup to larger-scale poisoning operations, to remove pocket gophers that escaped or avoided the poison baiting, is recommended.

Trapping is not recommended as the primary control method on large acreages because of labor requirements to simultaneously trap the entire area.

Poison baiting. Because of constantly changing labels, laws, and regulations, Oregon State University can assume no liability for the consequences of use of chemicals suggested here. In all cases, read and follow the directions and precautionary statements on the specific pesticide product label.

The application of toxicants to control pocket gopher damage generally is recommended when larger agricultural areas (10+ acres) are heavily infested. A variety of toxicants are available in the form of poison baits, such as oats and wheat seeds, alfalfa pellets, seed mixtures, and dried fruits.

Toxicants currently registered by the U.S. Environmental Protection Agency and the Oregon Department of Agriculture include strychnine, zinc phosphide, aluminum phosphide, acute anticoagulants such as diphacinone, and potassium nitrate and sulfur "smoke sticks."

Most commercially available baits have a seed base, but the pelletized alfalfa and grain-raisin-apple mixtures have been highly effective under some circumstances.

Use pesticides safely!

- **Wear** protective clothing and safety devices as recommended on the label. **Bathe or shower** after each use.
 - **Read** the pesticide label—even if you've used the pesticide before. **Follow closely** the instructions on the label.
 - **Be cautious** when you apply pesticides. **Know** your legal responsibility as a pesticide applicator. You may be liable for injury or damage.
-
-

Pocket gophers are active year-round, but the best times for baiting coincide with the best soil conditions for applying baits. Begin baiting in late winter and early spring when the soil softens, just before the pocket gophers reproduce and have young. Eliminating one female pocket gopher at this time will prevent several little pocket gophers from developing into problems later.

During summer, the soil generally hardens as it dries. There is less burrowing activity, and baits are more difficult to apply. With the rains in early fall, the soil begins to soften again, and burrowing activity of pocket gophers increases. Apply baits then to remove adults plus the young produced earlier in the breeding season.

Apply baits only to fresh burrow systems. Identify these by leveling mounds with a hard iron rake or by foot, returning in a day or two to determine where fresh activity is occurring. Revisit areas 2 to 3 days after baiting to search for fresh mounds, which indicate where pocket gophers avoided control. Such areas require additional baiting or trapping.

Because pocket gophers rapidly reinvade areas that have been cleared by poison baiting, survey such areas periodically so that any invading pocket gophers can be controlled quickly.

Applying poison baits underground to pocket gophers results in low hazard to nontarget wildlife. Some mice and voles may be accidentally poisoned in the burrow systems, but relatively few other nontarget animals contact the baits directly.

Poisoned pocket gophers almost always die below ground, so their carcasses are rarely available on the surface to nontarget scavengers such as hawks and owls. Avoid bait spillage, but if it occurs, bury baits promptly to avoid hazard to nontarget birds and mammals.

Hand-baiting. Hand-baiting is described in EC 1255 and is recommended only where infestations are localized on small (2 to 5 acres) areas. Hand-baiting is slow, requiring 7 to 20 hours to treat 1 acre.

Probe-bait dispensers. Probe-bait dispensers (Figure 4) allow probing for runways and dispensing the poison bait in one step. Their use is about twice as fast as hand-baiting. The probe-bait

dispensers generally require use of grain baits. (Pelleted baits and baits containing raisins and dried fruits usually won't pass through the dispensing mechanism.)

Push the probe-bait dispenser into the ground in a circular pattern around fresh mounds to find the runways. Once a runway is found (the dispenser suddenly sinks 2 to 4 inches deeper in the ground), a twist of a lever dispenses a measured amount of bait into the runway. Place three to five baits in runways around each cluster of fresh gopher mounds.

Burrow builder. Where pocket gopher infestations are severe on 10 or more acres, the burrow builder (Figure 5) is the most effective way to dispense baits.

The burrow builder is designed for use with a tractor of at least 25 horsepower and having a conventional three-point hitch. The device consists of a supporting frame, a depth-adjustable, burrow-forming torpedo at the end of a shank, a rolling coulter to cut surface trash and shallow roots ahead of the shank, a bait-metering device, and press wheels to drive the metering unit and close the knifelike slit made by the upper portion of the shank. The bait is dropped into the artificial burrow through a tube built into the shank.

The torpedo is pulled 6 to 10 inches below ground level, forming an artificial burrow. Baits are dispensed at 18- to 48-inch intervals. Pocket gophers use the artificial burrows where they intercept their own burrow system.

When they discover and eat the machine-placed baits, they're poisoned.

Pull the burrow builder at a speed of 2½ to 3½ miles per hour. An acre can be treated in 6 to 12 minutes, a marked improvement over baiting by hand or with the probe-bait dispenser.

For maximum effectiveness, the artificial burrow must be at the same approximate depth as natural gopher burrows. Dig into a burrow system, measure the depth, and adjust the depth of the torpedo as needed.

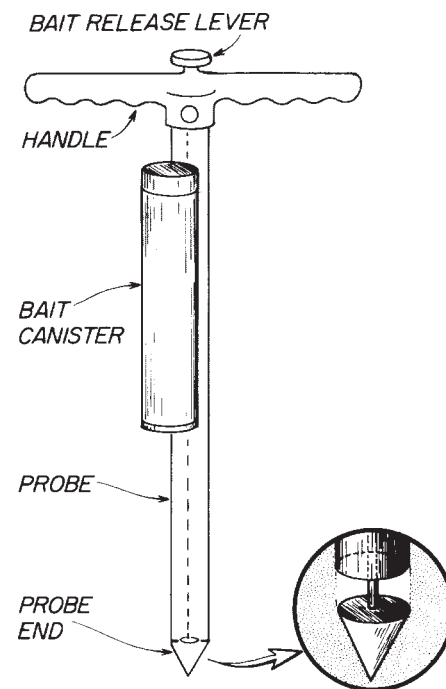

Figure 4.—Probe-bait dispenser.

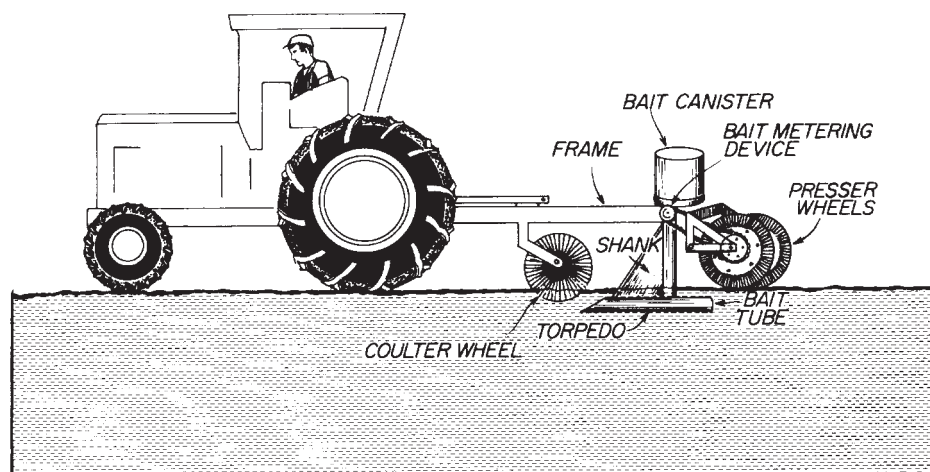

Figure 5.—Burrow builder.

The torpedo must be level under ground. If it is angled downward, it will be hard for the tractor to pull. If the torpedo is angled upward, it will not stay below ground. Build these artificial burrows 20 to 25 feet apart.

Soil conditions are critical for proper use of the burrow builder. If the soil is too dry, the burrow builder won't penetrate well, will pull hard, and the burrow will tend to cave in. A good rule of thumb: If the soil is too hard to easily push a hand probe 10 inches into the soil, it's too hard for the burrow builder.

The soil is moist enough when a handful of it is squeezed and retains its shape and doesn't crumble. If the soil is sticky when squeezed in a ball and sticks to the press wheels, it's too wet. In eastern Oregon, burrows may be formed in sandy soils 2 days after irrigation. Generally, the soil moisture should be near the upper limits of the range for good plowing or cultivating.

Here are a few helpful tips:

1. Scour the burrow-forming shank and torpedo thoroughly like a plow so they will form a smooth burrow. They will scour more quickly if the coulter is temporarily given a shallow setting (3 to 5 inches) in the ground.
2. Adjust the machine so that the torpedo is drawn through the soil parallel to the surface. This requires a certain amount of trial and error.
3. Carefully align the coulter wheel to cut directly in front of the burrow-forming shank at a depth of 4 to 6 inches, to minimize soil or sod disturbances.
4. Run the press wheels firmly on the ground, to close the narrow slit in the soil formed by the upper portion of the burrow-forming shank.
5. Lower the torpedo into the ground while the machine is in forward motion; likewise, withdraw it while you're still moving forward.

6. Raise the torpedo out of the ground to make turns. Some models will permit moderate turns; however, with all models, raise the torpedo out of the ground to make sharp turns.
7. Avoid stopping the tractor on an uphill pull with the torpedo buried; even a slight backward movement can clog the bait outlet.
8. At the end of each artificial burrow transect or at intervals of 1,000 feet, whichever is less, check the torpedo to make sure it's not clogged and that the bait tube is open.

To prevent pocket gophers in adjacent areas from invading treated areas, bait the perimeter of treated areas. Generally, building two additional burrows 20 to 25 feet apart around the treated areas is adequate.

Check the treated area after 2 weeks to make sure that gophers have not invaded from adjacent areas. You can treat such small invasions quickly by spot baiting or trapping.

Sources of supply

A manufacturer of probe-bait dispensers and burrow builders is listed below with approximate prices. Your county Extension agent has a listing of nearby distributors. The list isn't exhaustive but represents major manufacturers. The list is offered as an example only, and it does not represent endorsement by the OSU Extension Service.

Elston Co., Inc.
706 North Weber
Sioux Falls, SD 57103
605-336-7716
1-800-845-1385
<http://www.elstonmfg.com/>

Estimated prices:

Probe-bait dispensers, \$95
Burrow builders, \$1,118 + freight

For further reading

OSU Extension publication

deCalesta, D.S., and K. Asman,
Controlling Pocket Gopher Damage to Conifer Seedlings, EC 1255
(Corvallis, reprinted 1993). \$1.50

To order copies of the above publication, or additional copies of this publication, send the complete title and series number and a check or money order for the amount listed (payable to Oregon State University) to:

Publication Orders
Extension & Station Communications
Oregon State University
422 Kerr Administration
Corvallis, OR 97331-2119
Fax: 541-737-0817

We offer discounts on orders of 100 or more copies of a single publication. Call 541-737-2513 for price quotes.

You can view our Publications and Videos catalog and many of our publications on the World Wide Web at eesc.orst.edu

Other publications

Case, R.M., and B.A. Jasch, "Pocket gophers," in Timm, R.M. (ed.), *Prevention and Control of Wildlife Damage* (University of Nebraska Extension Service, Lincoln, 1994).

Salmon, T.P., and P. Gorenzel, *Pest Notes: Pocket Gophers*, University of California Agriculture and Natural Resources Publication 7433.

Verts, B.J., and L.N. Carraway, *Land Mammals of Oregon* (University of California Press, Berkeley and Los Angeles, 1998). 668 pages.



© 1998 Oregon State University. This publication may be photocopied or reprinted in its entirety for noncommercial purposes.

Produced and distributed in furtherance of the Acts of Congress of May 8 and June 30, 1914. Extension work is a cooperative program of Oregon State University, the U.S. Department of Agriculture, and Oregon counties.

Oregon State University Extension Service offers educational programs, activities, and materials—without regard to race, color, religion, sex, sexual orientation, national origin, age, marital status, disability, and disabled veteran or Vietnam-era veteran status—as required by Title VI of the Civil Rights Act of 1964, Title IX of the Education Amendments of 1972, and Section 504 of the Rehabilitation Act of 1973. Oregon State University Extension Service is an Equal Opportunity Employer.

Revised October 1998. Reprinted May 1999.

