

**MODERN ROUNDABOUTS  
FOR OREGON**

**#98-SRS-522**

by

Thaweesak Taekratok

for

Oregon Department of Transportation  
Research Unit  
200 Hawthorne SE, Suite B-240  
Salem, OR 97310

**June 1998**



1. Report No. OR-RD-98-17	2. Government Accession No.	3. Recipient's Catalog No.	
4. Title and Subtitle Modern Roundabouts for Oregon		5. Report Date June 1998	
		6. Performing Organization Code	
7. Author(s) Thaweesak Taekratok		8. Performing Organization Report No.	
9. Performing Organization Name and Address Mark Johnson Oregon Department of Transportation Preliminary Design Unit 207 Transportation Building Salem, Oregon 97310		10. Work Unit No. (TRAIS)	
		11. Contract or Grant No.	
12. Sponsoring Agency Name and Address Oregon Department of Transportation Research Unit 200 Hawthorne SE, Suite B-240 Salem, Oregon 97310		13. Type of Report and Period Covered	
		14. Sponsoring Agency Code	
15. Supplementary Notes			
16. Abstract  This report reviews current research and practice on modern roundabouts, both in the US and other countries. The report compares the advantages and disadvantages of roundabouts, summarizes safety implications, and discusses pedestrian and bicyclist considerations. Guidance from other states on the geometric design of roundabouts is reviewed, as are studies and formulas used to evaluate roundabout performance, measuring capacity and delay. Software models for roundabouts are reviewed. The report makes recommendations for considering and using roundabouts in Oregon, as well as identifying further research needs in this area.			
17. Key Words Roundabouts, intersections, design		18. Distribution Statement	
19. Security Classification (of this report) Unclassified	20. Security Classification (of this page) Unclassified	21. No. of Pages 102 + appendices	22. Price

## SI\* (MODERN METRIC) CONVERSION FACTORS

APPROXIMATE CONVERSIONS TO SI UNITS					APPROXIMATE CONVERSIONS FROM SI UNITS				
Symbol	When You Know	Multiply By	To Find	Symbol	Symbol	When You Know	Multiply By	To Find	Symbol
<b><u>LENGTH</u></b>					<b><u>LENGTH</u></b>				
in	inches	25.4	millimeters	mm	mm	millimeters	0.039	inches	in
ft	feet	0.305	meters	m	m	meters	3.28	feet	ft
yd	yards	0.914	meters	m	m	meters	1.09	yards	yd
mi	miles	1.61	kilometers	km	km	kilometers	0.621	miles	mi
<b><u>AREA</u></b>					<b><u>AREA</u></b>				
in <sup>2</sup>	square inches	645.2	millimeters squared	mm <sup>2</sup>	mm <sup>2</sup>	millimeters squared	0.0016	square inches	in <sup>2</sup>
ft <sup>2</sup>	square feet	0.093	meters squared	m <sup>2</sup>	m <sup>2</sup>	meters squared	10.764	square feet	ft <sup>2</sup>
yd <sup>2</sup>	square yards	0.836	meters squared	m <sup>2</sup>	ha	hectares	2.47	acres	ac
ac	acres	0.405	hectares	ha	km <sup>2</sup>	kilometers squared	0.386	square miles	mi <sup>2</sup>
mi <sup>2</sup>	square miles	2.59	kilometers squared	km <sup>2</sup>	<b><u>VOLUME</u></b>				
fl oz	fluid ounces	29.57	milliliters	mL	mL	milliliters	0.034	fluid ounces	fl oz
gal	gallons	3.785	liters	L	L	liters	0.264	gallons	gal
ft <sup>3</sup>	cubic feet	0.028	meters cubed	m <sup>3</sup>	m <sup>3</sup>	meters cubed	35.315	cubic feet	ft <sup>3</sup>
yd <sup>3</sup>	cubic yards	0.765	meters cubed	m <sup>3</sup>	m <sup>3</sup>	meters cubed	1.308	cubic yards	yd <sup>3</sup>
<b><u>MASS</u></b>					<b><u>MASS</u></b>				
oz	ounces	28.35	grams	g	g	grams	0.035	ounces	oz
lb	pounds	0.454	kilograms	kg	kg	kilograms	2.205	pounds	lb
T	short tons (2000 lb)	0.907	megagrams	Mg	Mg	megagrams	1.102	short tons (2000 lb)	T
<b><u>TEMPERATURE (exact)</u></b>					<b><u>TEMPERATURE (exact)</u></b>				
°F	Fahrenheit temperature	5(F-32)/9	Celsius temperature	°C	°C	Celsius temperature	1.8 + 32	Fahrenheit	°F

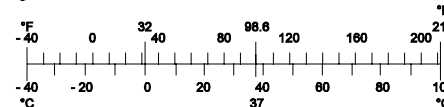

\* SI is the symbol for the International System of Measurement

## SELECTED METRIC VALUES FOR GEOMETRIC DESIGN

The AASHTO Task Force on Geometric Design has reviewed the "Policy on Geometric Design of Highways and Streets" and identified the following geometric design elements as critical elements in metric conversion.

<b>SPEED</b>	
Design Speed km/h	Running Speed km/h
30	(18.64 mph)
40	(24.85 mph)
50	(31.07 mph)
60	(37.28 mph)
70	(43.50 mph)
80	(49.71 mph)
90	(55.92 mph)
100	(62.14 mph)
110	(68.35 mph)
120	(74.56 mph)

<b>LANE WIDTH</b>		
2.7 m	(8.86 ft)	(1.56% less than 9' lane)
3.0 m	(9.84 ft)	(1.60% less than 10' lane)
3.3 m	(10.83 ft)	(1.55% less than 11' lane)
3.6 m	(11.81 ft)	(1.58% less than 12' lane)

<b>SHOULDERS</b>	
0.6 m	(1.97 ft)
1.2 m	(3.94 ft)
1.8 m	(5.91 ft)
2.4 m	(7.87 ft)
3.0 m	(9.84 ft)

<b>VERTICAL CLEARANCE</b>	
3.8 m	(12.47 ft)
4.3 m	(14.11 ft)
4.9 m	(16.08 ft)
The 4.9 m value is seen to be the critical value since the federal legislation required Interstate design to have 16 feet vertical clearance. Other vertical clearance values are not deemed to be as rigid as this value.	

<b>CLEAR ZONE</b>		
Urban Conditions	0.5 m	(1.64 ft)
Locals/Collectors	3.0 m minimum	(9.84 ft)

<b>CURBS</b>		
Curb Heights		
Mountable Curb	150 mm maximum	(5.91")
Barrier Curb	225 mm maximum	(8.86")
The definition of high speed/low speed has an impact on where curb is used:		
Low Speed	60 km/h or less design speed	
High Speed	80 km/h or more design speed	

<b>SIGHT DISTANCE</b>			
Stopping Sight Distance	Eye Height	1070 mm	(3.51 ft)
	Object Height	150 mm	(5.91 ft)
	Headlight Height	610 mm	(2 ft)
Passing Sight Distance	Eye Height	1070 mm	(3.51 ft)
	Object Height	1300 mm	(4.27 ft)

## **ACKNOWLEDGEMENTS**

This report has been made possible by ODOT funding support.

I would like to thank everybody who has helped me produce this document, including Mark Johnson and Elizabeth A. Hunt for coordinating work, Michael P. Ronkin for his help translating French guidelines, Garnet K. Elliott for her help acquiring the literature, Joni E. Reid for her editing work, and the Technical Advisory Committee for their helpful opinion.

Also, I would like to thank my graduate committee, including Professor Chris A. Bell, Professor Robert D. Layton, and Professor Robert J. Schultz.

## **DISCLAIMER**

This document is disseminated under the sponsorship of the Oregon Department of Transportation in the interest of information exchange. The State of Oregon assumes no liability of its contents or use thereof.

The contents of this report reflect the views of the author(s) who are solely responsible for the facts and accuracy of the material presented. The contents do not necessarily reflect the official views of the Oregon Department of Transportation.

This report does not constitute a standard, specification, or regulation.

# MODERN ROUNDABOUTS FOR OREGON

## TABLE OF CONTENTS

<b>1</b>	<b>EXECUTIVE SUMMARY .....</b>	<b>ix</b>
<b>1.0</b>	<b>INTRODUCTION .....</b>	<b>1</b>
1.1	BACKGROUND .....	1
1.2	PURPOSE OF THE REPORT .....	1
1.3	SCOPE AND OBJECTIVES OF THE REPORT .....	2
<b>2.0</b>	<b>MODERN ROUNDABOUTS .....</b>	<b>3</b>
2.1	HISTORY OF ROUNDABOUTS .....	4
2.2	TYPES OF ROUNDABOUTS .....	6
2.3	ADVANTAGES AND DISADVANTAGES .....	8
2.4	SITE LOCATIONS.....	9
2.4.1	<i>Appropriate Sites for Roundabouts</i> .....	9
2.4.2	<i>Inappropriate Sites for Roundabouts</i> .....	11
2.5	RECOMMENDATIONS FOR FURTHER CONSIDERATION.....	12
<b>3.0</b>	<b>SAFETY OF ROUNDABOUTS.....</b>	<b>13</b>
3.1	SAFETY BENEFITS .....	13
3.2	TYPES OF ACCIDENTS AT ROUNDABOUTS .....	13
3.3	ACCIDENT STUDIES .....	14
3.4	ACCIDENT RATES .....	20
3.5	RECOMMENDATIONS FOR FURTHER CONSIDERATION.....	24
<b>4.0</b>	<b>PEDESTRIAN AND BICYCLIST CONSIDERATIONS .....</b>	<b>25</b>
4.1	PEDESTRIANS .....	25
4.1.1	<i>French Design Practice for Pedestrians at Roundabouts</i> .....	26
4.2	BICYCLISTS .....	27
4.2.1	<i>Australia Recommendations</i> .....	27
4.2.2	<i>The Netherlands Recommendations</i> .....	28
4.2.3	<i>French Recommendations</i> .....	30
4.3	RECOMMENDATIONS FOR FURTHER CONSIDERATION.....	32
<b>5.0</b>	<b>GEOMETRIC DESIGN OF ROUNDABOUTS .....</b>	<b>33</b>
5.1	DESIGN VEHICLE.....	34
5.2	DESIGN SPEED.....	35
5.3	SIGHT DISTANCE .....	36
5.3.1	<i>Australia and Maryland</i> .....	36
5.3.2	<i>Florida</i> .....	37
5.3.3	<i>California</i> .....	39

5.4	DEFLECTION .....	39
5.4.1	<i>Deflection at Roundabouts with One Circulating Lane</i> .....	39
5.4.2	<i>Deflection At Roundabouts with Two or Three Circulating Lanes</i> .....	40
5.4.3	<i>French Recommendation for Deflection</i> .....	42
5.5	CENTRAL ISLAND.....	42
5.6	CIRCULATING WIDTH .....	43
5.7	INSCRIBED CIRCLE DIAMETER (ICD) .....	43
5.8	ENTRY DESIGN.....	44
5.9	EXIT DESIGN .....	47
5.10	SPLITTER ISLAND.....	48
5.11	GRADES AND SUPERELEVATION.....	49
5.12	PAVEMENT MARKING.....	50
5.12.1	<i>Yield Line</i> .....	50
5.12.2	<i>Splitter Islands and Approaches</i> .....	50
5.12.3	<i>Pavement Marking in the Circulating Roadway</i> .....	50
5.13	SIGNING .....	50
5.14	LIGHTING.....	53
5.15	LANDSCAPING .....	54
5.16	RIGHT-TURN SLIP LANE .....	55
5.17	RECOMMENDATIONS FOR FURTHER CONSIDERATION.....	55
5.17.1	<i>Recommendations for Oregon</i> .....	55
<b>6.0</b>	<b>CAPACITY AND DELAY AT ROUNDABOUTS.....</b>	<b>59</b>
6.1	THE REVIEW OF CAPACITY FORMULAS .....	59
6.1.1	<i>Regression Capacity Formula</i> .....	60
6.1.2	<i>Gap Acceptance Theory and Roundabout Capacity</i> .....	64
6.2	THE STUDY OF DELAY FORMULAS .....	70
6.2.1	<i>The UK Delay Equation</i> .....	71
6.2.2	<i>The Australian Delay Formula</i> .....	74
6.3	THE CAPACITY OF ROUNDABOUTS IN THE US .....	78
6.3.1	<i>Capacity Studies in the US</i> .....	78
6.3.2	<i>Capacity Formula Use in US Roundabout Guidelines</i> .....	79
6.3.3	<i>Proposed Formula in the New Highway Capacity Manual</i> .....	79
6.4	DISCUSSION .....	80
6.5	RECOMMENDATIONS FOR FURTHER CONSIDERATION.....	83
<b>7.0</b>	<b>SOFTWARE MODELS FOR ROUNDABOUTS.....</b>	<b>85</b>
7.1	ARCADY.....	85
7.2	RODEL .....	86
7.3	SIDRA.....	88
7.4	COMPARISON OF ARCADY, RODEL AND SIDRA.....	90
7.5	OTHER SOFTWARE MODELS .....	91
7.6	RECOMMENDATIONS FOR FURTHER CONSIDERATION.....	92
<b>8.0</b>	<b>OTHER RELATED TOPICS.....</b>	<b>93</b>
8.1	PUBLIC PERCEPTION .....	93
8.2	FUNCTIONAL HIERARCHY.....	93



8.3 PUBLIC TRANSIT.....	94
<b>9.0 REFERENCES.....</b>	<b>95</b>

APPENDIX A: Montpelier’s Modern Roundabout at Keck Circle Neighborhood Opinion Survey

## LIST OF TABLES

<b>Table 2.1: Distinguishing Features of Roundabouts and Traffic Circles.....</b>	<b>4</b>
<b>Table 2.2: Advantages and Disadvantages Comparison.....</b>	<b>9</b>
<b>Table 3.1: Accident Rate and Accident Cost Rate .....</b>	<b>15</b>
<b>Table 3.2: Accident Rates .....</b>	<b>20</b>
<b>Table 3.3: Equations for the Prediction of Accident Frequencies at Roundabouts.....</b>	<b>21</b>
<b>Table 5.1: Comparison of Design Guidelines.....</b>	<b>34</b>
<b>Table 5.2: Approach Sight Distance .....</b>	<b>36</b>
<b>Table 5.3: Stopping Sight Distance.....</b>	<b>39</b>
<b>Table 5.4: Approaching Sight Distance.....</b>	<b>39</b>
<b>Table 5.5: Deflection Curve Radii .....</b>	<b>40</b>
<b>Table 5.6: Widths Required for Vehicles to Turn One, Two or Three Abreast.....</b>	<b>43</b>
<b>Table 5.7: Turning Widths Required for Normal Roundabouts.....</b>	<b>45</b>
<b>Table 5.8: Derived Pavement Widths for Turning Roadways for Different Design Vehicles .....</b>	<b>46</b>
<b>Table 5.9: Lighting .....</b>	<b>53</b>
<b>Table 5.10: Minimum Horizontal Illuminance at the Curblines .....</b>	<b>53</b>
<b>Table 6.1: Formula for Calculating Roundabout Capacity .....</b>	<b>63</b>
<b>Table 6.2: Parameters for Linear Regression.....</b>	<b>63</b>
<b>Table 6.3: Dominant Stream Follow-up Headways .....</b>	<b>68</b>
<b>Table 6.4: Ratio of Critical Acceptance Gap to Follow-up Headway .....</b>	<b>68</b>
<b>Table 6.5: Adjustment Times for the Dominant Stream Follow-up Headway.....</b>	<b>69</b>
<b>Table 6.6: Sub-dominant Stream Follow-up Headway.....</b>	<b>69</b>
<b>Table 6.7: Average Headway Between Bunched Vehicles in the Circulating Traffic and the Number of Effective Lanes in the Circulating Roadway .....</b>	<b>69</b>
<b>Table 6.8: Proportion of Bunched Vehicles .....</b>	<b>70</b>
<b>Table 6.9: Geometric Delay for Stopped Vehicles.....</b>	<b>76</b>
<b>Table 6.10: Geometric Delay for Vehicles which Do Not Stop.....</b>	<b>77</b>
<b>Table 6.11: Site Characteristics .....</b>	<b>78</b>
<b>Table 6.12: Findings Comparison.....</b>	<b>79</b>
<b>Table 6.13: Critical Gaps and Follow-up Times.....</b>	<b>80</b>
<b>Table 6.14: Summary of Gap Acceptance Method and Empirical Method .....</b>	<b>80</b>
<b>Table 6.15: Entering Capacity Comparison .....</b>	<b>81</b>
<b>Table 6.16: Comparison of the Australia and US Capacity Formula .....</b>	<b>82</b>
<b>Table 7.1: Main Features of the SIDRA Method for Roundabout Capacity Estimation....</b>	<b>88</b>
<b>Table 7.2: Enhancements to Roundabout Analysis Method Introduced in SIDRA .....</b>	<b>89</b>

## LIST OF FIGURES

Figure 2.1: Basic Geometric Elements of a Roundabout .....	3
Figure 2.2: Henard’s Suggested Gyrotory Crossroads .....	5
Figure 2.3: Roundabout Movements .....	10
Figure 3.1: Different Types of Accidents in Roundabouts .....	14
Figure 3.2: Absolute Number of Accidents per Year.....	15
Figure 3.3: Portion of Accidents with Injured Persons or Damage Only.....	16
Figure 3.4: Path .....	17
Figure 3.5: Lane .....	17
Figure 3.6: Non-Lane .....	17
Figure 3.7: Predicted Number of Bicycle Accidents According to the VTI Model.....	23
Figure 4.1: Relationship Between Speed and Pedestrian Fatality Rate .....	25
Figure 4.2: Roundabout for Mixed Traffic.....	29
Figure 4.3: Roundabout with Cycle Lane .....	29
Figure 4.4: Roundabout with Separate-Lying Cycle-Track and Cyclists Having Right of Way.	30
Figure 5.1: Geometric Elements of a Roundabout .....	33
Figure 5.2: Design Vehicles for California .....	35
Figure 5.3: Sight Distance Requirements.....	37
Figure 5.4: Gap Acceptance Sight Distance.....	38
Figure 5.5: Deflection Criteria for a Single Lane Roundabout .....	40
Figure 5.6: Deflection Criteria for a Multi-lane Roundabout .....	41
Figure 5.7: Determination of Path Curvature.....	41
Figure 5.8: Circulating Roadwidths for Roundabouts.....	44
Figure 5.9: Typical Roundabout Entrance, Exit, and Splitter Island Geometric Configuration ..	44
Figure 5.10: Typical Exit to an Undivided Road .....	48
Figure 5.11: Typical Signing for a State Route Roundabout .....	51
Figure 5.12: Typical Signing for a Local Road Roundabout .....	52
Figure 5.13: Plan of Landscaped Central Island .....	54
Figure 5.14: Interstate Design VehicleWB-20 .....	55
Figure 6.1: Definition of Geometric Parameters .....	61
Figure 6.2: Parameters for Exponential Analysis.....	63
Figure 6.3: Relationship between Entry and Circulating Traffic Volumes.....	66
Figure 6.4: The Calculation of Geometric Delay .....	73
Figure 6.5: Definition of the Terms Used in Table 6.9 and 6.10 .....	75
Figure 6.6: Proportion of Vehicles Stopped on a Single Lane Roundabout .....	77
Figure 6.7: Proportion of Vehicles Stopped on a Multi-Lane Entry Roundabout .....	78
Figure 6.8: Comparison of Capacity Formulas .....	82
Figure 7.1: Data Entry/Edit Screens for Both Modes of RODEL.....	87
Figure 7.2: Volume-Delay Comparison .....	90
Figure 7.3: Effect of Inscribed Circle Diameters on RODEL and SIDRA Predicted Capacities	91

## EXECUTIVE SUMMARY

Roundabouts have been widely accepted in foreign countries for decades. Recently, roundabouts have been used in Florida, Maryland and Vermont. While roundabouts have been proposed as alternative solutions in Oregon, the Oregon Department of Transportation (ODOT) has limited expertise for evaluating these proposals. A roundabouts study was conducted to better comprehend the design and usage of roundabouts. The objective is to evaluate the feasibility of roundabouts as an intersection control alternative in Oregon.

This report provides information collected from the study. An expert task group will further evaluate the data available to determine applicability in Oregon.

### MODERN ROUNDABOUTS

A roundabout is a form of intersection design and control which accommodates traffic flow in one direction around a central island, operates with yield control at the entry points, and gives priority to vehicles within the roundabout (circulating flow). Table S.1 identifies several characteristics that distinguish a modern roundabout from the more general form of a traffic circle.

**Table S.1: Distinguishing Features of Roundabouts and Traffic Circles**

	<b>Modern Roundabout</b>	<b>Traffic Circle</b>
Control at Entry	Yield sign for entering vehicles.	Stop, signal, or give priority to entering vehicles.
Operational Characteristics	Vehicles in the roundabout will have a priority over the entering vehicle.	Allow weaving areas to resolve the conflicted movement.
Deflection	Use deflection to control the low speed operation through roundabout.	Some large traffic circles provide straight path for major movement with higher speed.
Parking	No parking is allowed on the circulating roadway.	Some larger traffic circles permit parking within the circulating roadway.
Pedestrian Crossing	No pedestrian activities take place on the central island.	Some larger traffic circles provide for pedestrian crossing to, and activities on, the central island.
Turning Movement	All vehicles circulate around the central island.	Mini-traffic circles, left-turning vehicles are expected to pass to the left of the central island.
Splitter Island	Required.	Optional.

The roundabout concept was first invented in the early 1900's and deployed throughout Europe and America. During the 1950's there was a loss of confidence in roundabouts, due mainly to the problem of traffic locking and the increasing number of accidents. Many were replaced by traffic signals.

In 1966, the off-side priority rule (an entering vehicle gives way to vehicles in the roundabout) and the yield at entry operation enhanced roundabout capacity and safety performance. The success of this modern roundabout provoked renewed interest in roundabouts worldwide. Table S.2 presents some advantages and disadvantages of roundabouts.

**Table S.2: Advantages and Disadvantages Comparison**

Category	Advantages	Disadvantages
Safety	<ul style="list-style-type: none"> <li>- There are a reduced number of conflict points compared to uncontrolled intersection.</li> <li>- Lower operational speeds yield less severe and fewer accidents.</li> <li>- Slower speeds because of intersection geometry reduce accidents.</li> </ul>	<ul style="list-style-type: none"> <li>- Since roundabouts are unfamiliar to the average driver in the US, there is likely to be an initial period where accidents increase.</li> <li>- Signalized intersections can preempt control for emergency vehicles.</li> </ul>
Capacity	<ul style="list-style-type: none"> <li>- Traffic <i>yields</i> rather than <i>stops</i>, often resulting in the acceptance of smaller gaps.</li> <li>- For isolated intersections, roundabouts should give higher capacity/lane than signalized intersections due to the omission of lost time (red and yellow) at signalized intersections.</li> </ul>	<ul style="list-style-type: none"> <li>- Where the coordinated signal network can be used, a signalized intersection will increase the overall capacity of the network.</li> <li>- Signals may be preferred at intersections that periodically operate at higher than designed capacities.</li> </ul>
Delay	<ul style="list-style-type: none"> <li>- Overall delay will probably be less than for an equivalent volume signalized intersection (this does not equate to a higher level of service).</li> <li>- During the off-peak, signalized intersections with no retiming produce unnecessary delays to stopped traffic when gaps on the other flow are available.</li> </ul>	<ul style="list-style-type: none"> <li>- Drivers may not like the geometric delays which force them to divert their cars from straight paths.</li> <li>- When queuing develops, entering drivers tend to force into the circulating streams with shorter gaps. This may increase the delays on other legs and the number of accidents.</li> </ul>
Cost	<ul style="list-style-type: none"> <li>- In general, less right-of-way is required.</li> <li>- Maintenance costs of signalized intersections include electricity, maintenance of loops, signal heads, controller, timing plans (roundabout maintenance includes only landscape maintenance, illumination, and occasional sign replacement).</li> <li>- Accident costs are low due to the low number of accidents and severity.</li> </ul>	<ul style="list-style-type: none"> <li>- Construction costs may be higher.</li> <li>- In some locations, roundabouts may require more illumination, increasing costs.</li> </ul>
Pedestrians and Bicyclists	<ul style="list-style-type: none"> <li>- A splitter island provides a refuge for pedestrians that will increase safety.</li> <li>- At low speed and low traffic volume, roundabouts should improve safety for bicyclists.</li> </ul>	<ul style="list-style-type: none"> <li>- A splitter island may cause difficulty to people using wheelchairs.</li> <li>- Tight dimensions of roundabouts create an uncomfortable feeling to bicyclists.</li> <li>- Longer paths increase travel distances for both pedestrians and bicyclists.</li> <li>- Roundabouts may increase delay for pedestrians seeking acceptable gaps to cross.</li> </ul>

To make roundabouts a success, the appropriate site criteria are necessary. For instance, a roundabout should not be located close to a signalized intersection where a backup queue from the signalized intersection to the roundabout is possible.

Roundabouts can be classified based on their sizes and applications, as normal, mini or small, double, signalized, interchange, or ring junction. Following the recommendations by the author in Chapter 2, three types of roundabouts could be further investigated for consideration in Oregon; mini or small roundabouts, normal roundabouts, and roundabout interchanges.

## **SAFETY**

There is an expected reduction in accident numbers and severity at roundabouts compared to other control alternatives. Based on numerous studies, higher safety at roundabouts is due to the following:

- Fewer conflict points. For comparison, an uncontrolled four-legged intersection has 28 conflict points, but a roundabout has only eight conflict points.
- No left-turn accidents, the cause of most fatal or serious accidents at cross intersections.
- Simple decision-making at the entry point.
- Slow relative speeds of all vehicles in the conflict area.
- Splitter islands provide refuge for pedestrians and permit them to cross one direction of traffic at a time.

## **PEDESTRIAN AND BICYCLIST CONSIDERATIONS**

One of the objectives in the design of roadway facilities is to provide mobility and safety for all road users, i.e., motorists, pedestrians, and bicyclists. Providing safe mobility for pedestrians and bicyclists can be complex. The roundabout-pedestrian, and roundabout-bicyclist design aspects are compared to existing design standards in the report.

For a roundabout implementation plan in Oregon, some concerns need to be addressed or further study needed to address the following pedestrian and bicyclist issues:

- Identification of priority assignments between motorists and pedestrians,
- Use of marked or unmarked crosswalks,
- Establishment of site criteria when pedestrians and bicyclists are concerned,
- Determination of the proper location of crosswalks,
- Incorporation of the needs of impaired pedestrians,
- Determination of the appropriate size of splitter islands,
- Recommendations for bicycle lanes including exclusive bicycle lanes.

## **GEOMETRIC DESIGN OF ROUNDABOUTS**

Figure S.1 illustrates the basic geometric features of a roundabout.

For the purpose of this report, three US design guidelines (Florida, Maryland and California), the Australia design guideline, and partial translation of the French design guideline are investigated and summarized. Recommendations in the following areas are proposed for consideration and future development in Oregon: design vehicle, design speed, approach characteristic, entry and exit width, circulating width, entry and exit curve, sight distance, deflection, central island, splitter island, and superelevation.

## **CAPACITY AND DELAY AT ROUNDABOUTS**

There has been significant work on methodologies to evaluate the functional performance of roundabouts. Capacity and delay are used by most countries as a measure of performance. Since ODOT uses the volume/capacity ( $v/c$ ) ratio to evaluate intersection performance, more attention is paid to the capacity formula. Moreover, both of the delay formulas presented in the report require a  $v/c$  ratio for computation.

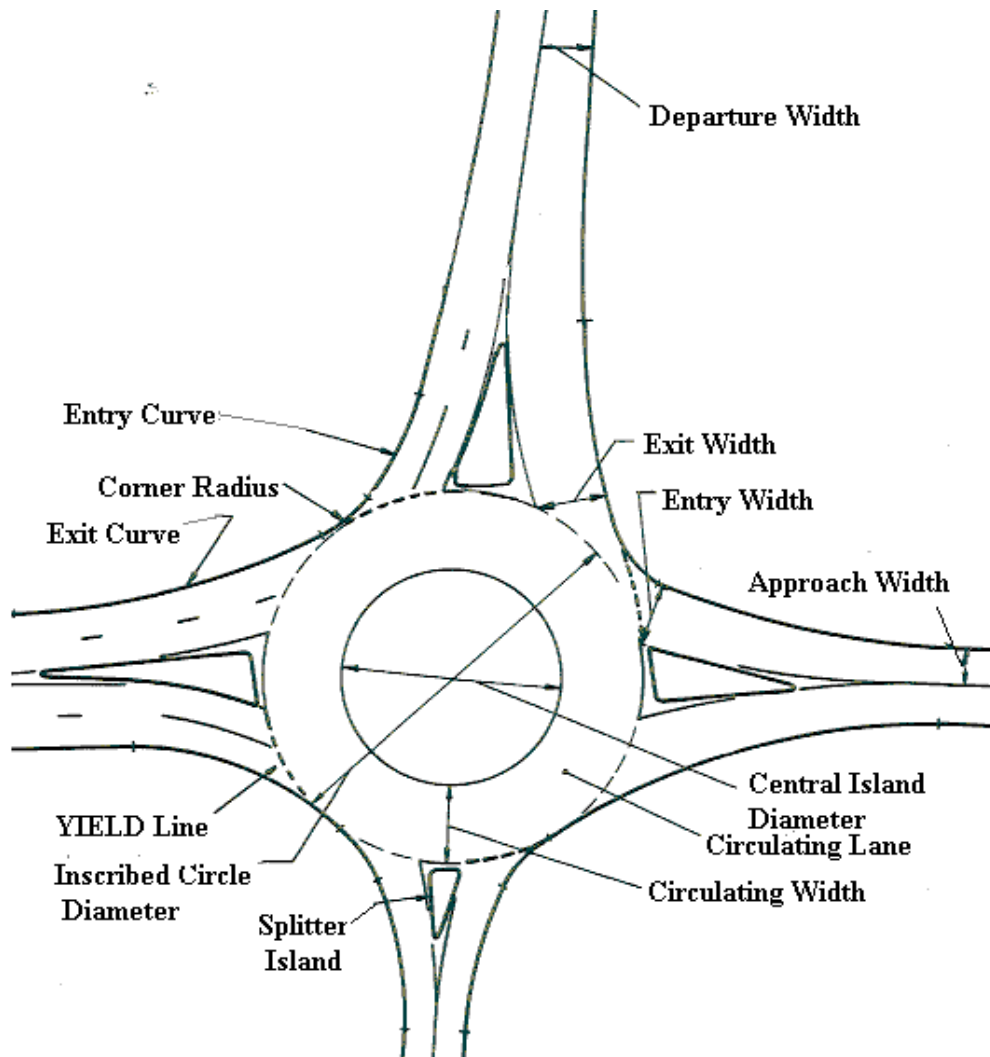

Figure S.1: Geometric Elements of a Roundabout (*Adapted from Austroad 1993*)

This study compares the capacity formulas, but certain conclusions cannot yet be drawn. For future implementation in Oregon, three possible options are available to determine roundabout capacity:

1) Use the Available Capacity Formulas

This is a good temporary solution until further study is conducted. The lower bound US capacity formula is suggested for a single lane, low or middle volume roundabout. For multilane roundabouts, a conservative value from the Australian and German formula is recommended at this point, since roundabouts are new to Oregon.

2) Wait for Research Results from the National Study

Currently, a national study is being conducted with funding support from FHWA. The research, to be complete in mid 1999, is intended to present design guidelines for general use in the US.

### 3) Adopt a Formula for Oregon

An Oregon formula can be adapted from field experiment and simulation. Basic parameters, i.e., critical gap, follow-up time, and headway distribution can be collected from field experiments. Simulation software then can be used to generate the potential capacity and the appropriate formula can be determined.

## **SOFTWARE MODELS FOR ROUNDABOUTS**

The objective of this study was not to acquire or evaluate existing software used for developing roundabouts, but to obtain information on available resources for roundabout analysis and design. Currently, three major software packages from other countries are used to analyze or design roundabouts: SIDRA, ARCADY, and RODEL.

Recently, a test of the SIDRA program in the US environment found agreement between SIDRA delay output and collected field data at low volume. The RODEL package has been used to design roundabouts in the US. However, there has been no study or information on the ability of this program to predict roundabout performance in the US.

## **OTHER RELATED TOPICS**

### **Public Perception**

To avoid public opposition, successful proposals start with educating people about the difference between roundabouts and traffic circles. Brochures, videotapes, and mass media can be used during the development stage. The public will begin to understand, and opposition will be gradually reduced. This strategy has been successful in improving public perception in Florida, Maryland, and Vermont.

### **Functional Hierarchy**

Roundabouts should be appropriate at intersections with similar functional classes. Another appropriate location is the transition between a freeway ramp and an arterial, when speeds on the ramp are approximately equal to the arterial street.

### **Public Transit**

A bus stop can be situated on an entrance leg, upstream from the crosswalk (in a pullout), or on an exit lane. On larger roundabouts, a bus pullout can be considered on the outside perimeter of the circulation roadway.

## **CONCLUSIONS**

Information summarized in this report will be used to develop guidance for roundabout use in Oregon. The Technical Advisory Committee will select an expert task group to further evaluate the issues.

Roundabouts should be considered as a form of traffic control to improve safety of intersections where accidents are high and severity is prominent. Roundabouts can be a good replacement for all-way stop control where traffic volumes are high, because priority is assigned to circulating traffic and yield-at-entry control allows vehicles to enter without stopping when gaps are available.

In order to implement roundabouts successfully, public involvement during the planning stage is important. A task force should be established to develop a public involvement strategy. Educating people on the difference between a traffic circle and a modern roundabout is necessary for success.



# **1.0 INTRODUCTION**

## **1.1 BACKGROUND**

Since being widely-accepted in Europe and Australia, roundabouts have been investigated or constructed as replacements or alternatives to conventional intersections by several highway agencies in the United States, including Florida, Maryland, Vermont, Colorado, Nevada and California. At least two states, Florida and Maryland, have published guidelines for the design and/or justification of roundabouts. Moreover, the Federal Highway Administration (FHWA) is initiating and supporting research on capacity and microsimulation of roundabouts. The new Highway Capacity Manual (1997) has also included the capacity analysis for roundabouts. As a result, interest in modern roundabouts is increasing throughout the United States.

Many early applications of roundabouts eventually failed. In Germany, many roundabouts, especially those constructed during the 1930s and 1950s, were rebuilt into signalized intersections as a result of poor capacity estimations and bad accident experiences. At the same time in the United States, traffic circles had been declared to be a failed traffic control device since they were known to have high accident rates and long delays.

Some researchers explained that the failures occurred because roundabouts were originally designed for merging and weaving maneuvers at relatively high speeds, and thus required large diameters. Unfortunately, the merge distance was always too short for the speed and volume of traffic. The high-speed operations and the short distances were too difficult for drivers to safely maneuver their cars. Another reason for the failure was the design of the entering road square to the circulating roadway and controlled by a stop sign. Entering drivers were required to first stop, then turn right through 90 degrees, thereby severely limiting the capacity of the approach.

In the mid-1960s, the United Kingdom adopted the “offside priority rule” for roundabouts, requiring entering drivers to give way to those already on the roundabouts. This prevented traffic locking and allowed free-flow movement on the circulating roadway. It changed the drivers’ task of merging and weaving at high speeds to the task of accepting a gap in traffic circulating at low speed.

With this new concept, safe and efficient operation of the roundabout now depends on effective measures to reduce vehicle speed. Slower traffic movement means a large central island is no longer needed, and thus the use of much smaller roundabouts has become feasible. Consequently, there has been an increase in new and retrofitted roundabouts in other countries, including Australia, France, Norway, Germany, as well as in the US.

## **1.2 PURPOSE OF THE REPORT**

The Oregon Department of Transportation (ODOT), local jurisdictions, and their consultants are looking for alternative intersection solutions. Roundabouts are one of the proposed solutions,

however, ODOT currently has no guidelines for design or evaluation of roundabouts. The Department has limited knowledge of this new traffic control device's design and operational characteristics. To better comprehend the design and usage of roundabouts, a study of current practice was conducted for the ODOT Research Unit and the Preliminary Design Section.

The objective of the study was to evaluate the feasibility of roundabouts as an intersection control solution. The study was divided into two stages, a literature review of roundabouts, and recommendations for their implementation in Oregon.

The first stage collected available publications that address the issues associated with design, operation, safety, and public perception of roundabouts. The collected information will be compiled and summarized for further evaluation and consideration. During stage two, information gathered from the literature review in stage one will be used to evaluate implementation of roundabouts in Oregon. An expert task group selected by the TAC will make the evaluation and develop an implementation plan based on the findings from the synthesis. The plan will identify any required changes in statute as well as desirable public acceptance and education activities. In addition, workshops or other methods will be recommended for providing the results of the study to ODOT and local jurisdictions.

### **1.3 SCOPE AND OBJECTIVES OF THE REPORT**

This report is the completed stage one literature synthesis for modern roundabouts in Oregon, initiated by the ODOT Research Unit and the Preliminary Design Unit.

The primary objectives of this report are:

- 1) To present a comprehensive review of all technical literature addressing the use, safety, design, and operation of roundabouts;
- 2) To summarize and compare the different guidelines which have been accepted for practice, and to address any conflicts within guidelines that need to be taken into consideration for further implementation;
- 3) To identify which part of existing information is insufficient and/or needs to be studied in stage two.

This report provides information for further study as well as the recommendations on the possible uses of modern roundabouts in Oregon.

## 2.0 MODERN ROUNDABOUTS

A roundabout is a form of intersection design and control which accommodates traffic flow in one direction around a central island, operates with yield control at the entry point, and gives priority to vehicles within the roundabout (circulating flow). Figure 2.1 illustrates the basic geometric elements of a roundabout.

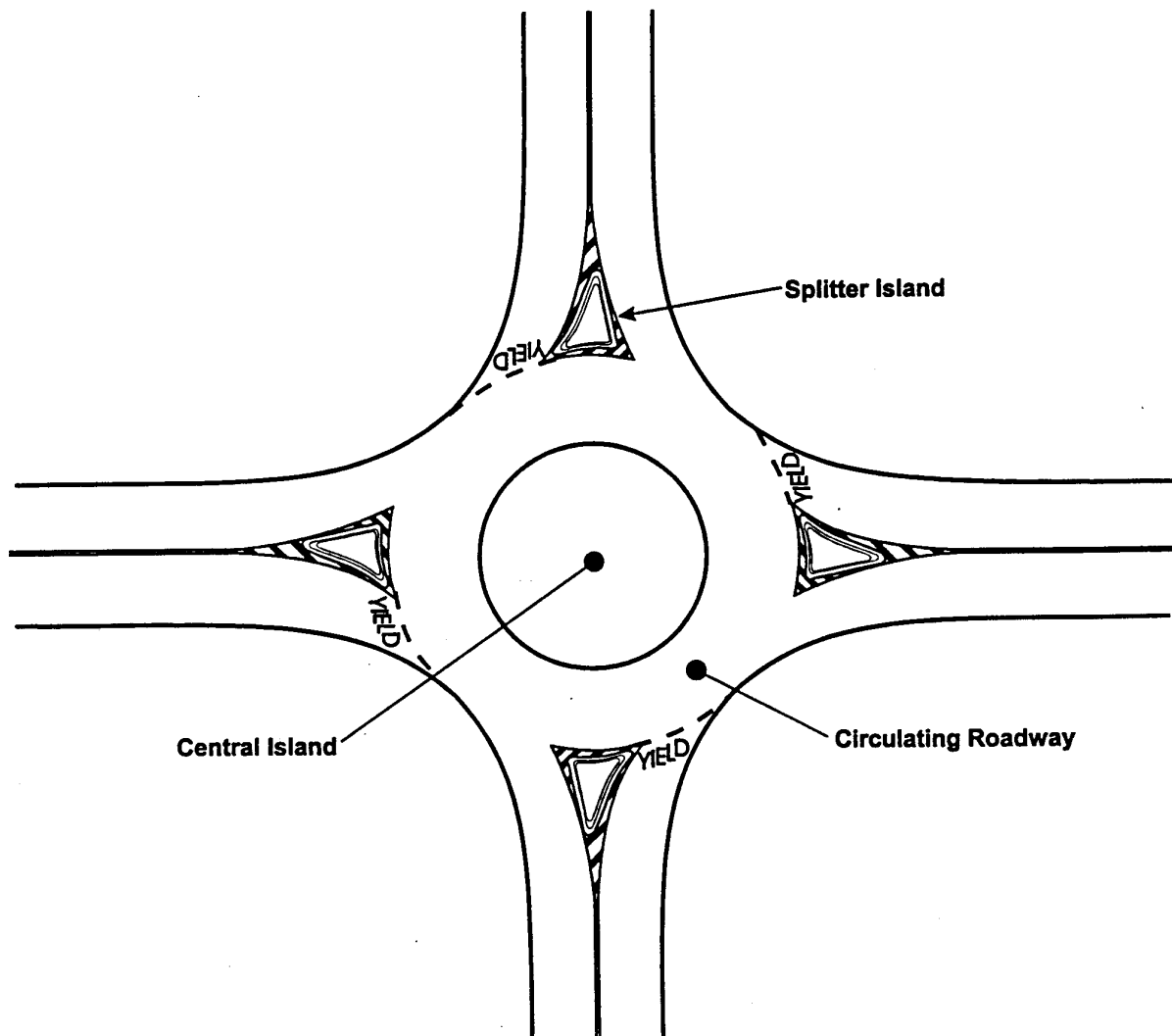

Figure 2.1: Basic Geometric Elements of a Roundabout (*Florida 1996*)

The Florida Roundabout Guide (FRG) (*Florida 1996*) identifies several characteristics that distinguish a modern roundabout from the more general form of a traffic circle. Any traffic circle that does not exhibit these characteristics is not considered a modern roundabout. The common characteristics defining a roundabout are shown in Table 2.1.

**Table 2.1: Distinguishing Features of Roundabouts and Traffic Circles** (*Adapted from Florida 1996*)

	<b>Modern Roundabout</b>	<b>Traffic Circle</b>
Control at Entry	Yield sign for entering vehicles.	Stop, signal, or give priority to entering vehicles.
Operational Characteristics	Vehicles in the roundabout will have a priority over the entering vehicle.	Allow weaving areas to resolve the conflicted movement.
Deflection	Use deflection to control the low speed operation through roundabout.	Some large traffic circles provide straight path for major movement with higher speed.
Parking	No parking is allowed on the circulating roadway.	Some larger traffic circles permit parking within the circulating roadway.
Pedestrian Crossing	No pedestrian activities take place on the central island.	Some larger traffic circles provide for pedestrian crossing to, and activities on, the central island.
Turning Movement	All vehicles circulate around the central island.	Mini-traffic circles, left-turning vehicles are expected to pass to the left of the central island.
Splitter Island	Required.	Optional.

## 2.1 HISTORY OF ROUNDABOUTS

Mike Brown, in his book “The Design of Roundabouts” (*Brown 1995*) gave a review of the history of roundabouts in Europe and the US. The first concept of gyratory operation was invented by Eugene Henard in 1903, where all the traffic would be required to circulate in one direction (see Figure 2.2). The earliest practical use of a gyratory system was the Columbus Circle installed by William Phelps Eno in New York in 1905. The first roundabout in Paris at the Place De l’Etoile was built in 1907. In the UK during 1925-1926, roundabouts were introduced in London, at Aldwych, Parliament Square, Hyde Park Corner, Marble Arch, and Trafalgar Square. The gyratory operational concept, or ‘circus’, continued to spread and was frequently recommended for busy intersections of more than four legs. Design was based solely on commonsense and experience.

The first use of the word ‘roundabout’ appeared in the Ministry of Transport and the Town Planning Institute Circular No. 302 in 1929. This circular was the first to give general guidelines for roundabout design. The design allowed a circular or polygon central island shape, depending on the number of legs. The guideline was updated purposely to improve safety. In 1936, Knight and Beddington suggested an adaptation to a circular central island, since better performance had been observed.

In the US, the first design guideline for a roundabout (called rotary) was published in 1942 by the American Association of State Highway Officials (AASHO) (*Todd 1988*). A rotary was defined as an intersection where all traffic merges into and emerges from a one-way road around a central island. The general concept was that large radii gave long weaving sections, on which both high speeds and high capacities could be maintained. The design was intended for vehicle speeds not less than 25 mph (40 km/h) and required a central island radius of at least 75 ft (23 m) so that entering vehicles could merge and interweave with those on the circulating roadway. The highest design speed contemplated was 40 mph (64 km/h), a speed that required a central island radius of 270 ft (82 m) or more, depending on the superelevation of the circulating roadway. The 1942 AASHO publication considered the use of rotaries impractical for a total intersection

demand above 5000 vehicles per hour. The 1954 and 1965 AASHO 'Blue Books' gave 3000 vehicles per hour as the maximum practical capacity.

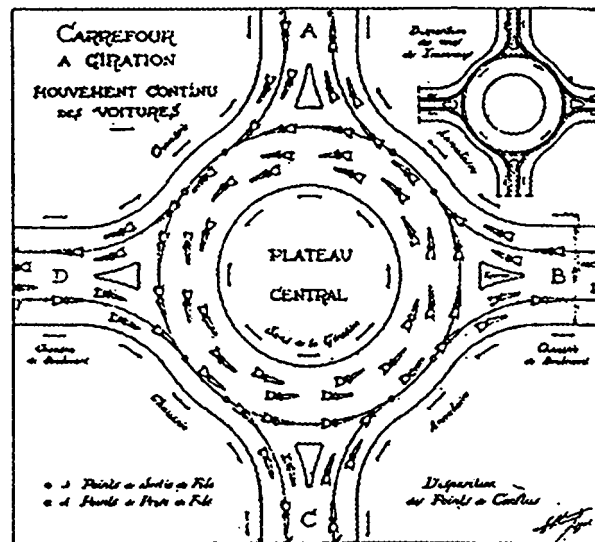

Figure 2.2: Henard's Suggested Gyratory Crossroads (Brown 1995)

In the early roundabout design and operation, roundabouts were operated with weaving sections. There were no set rules for driver behavior at roundabouts and no right of way was given to a particular traffic stream. Later, the “give-way-to-the-right” priority rule was introduced. One main problem of this priority rule was that it created locking within the roundabout.

From about 1950, due mainly to the problem of locking and an increasing number of accidents resulting from drivers disobeying the traffic rule, there was a loss of confidence in roundabouts as an effective form of intersection control. Improvements in traffic signals and the invention of coordinated traffic signal networks also made roundabouts less preferable and many were replaced. The grid-road network in the US favored the use of coordinated traffic signals. In Germany, roundabout failure was due to a lack of suitable capacity estimation, a high accident rate and congestion due to the misinterpretation of the priority rules.

In 1966, the survival of roundabouts in the UK was enhanced with the new assigned off-side priority rule (an entering vehicle gives way to circulating vehicles) and the yield-at-entry operation. With this new priority rule, entry was now controlled by the ability of entering drivers to detect gaps in the circulating flow. An entering vehicle simply merged into any suitable gap in the circulating flow and diverged as it reached the desired exit. This prevented vehicles from entering when no gap in the circulating stream was available, avoiding the locking problem. Moreover, the capacity of roundabouts was no longer dependent on the weaving operation, but on the availability of gaps. This increased both the capacity and safety of roundabouts. Continued improvements based on the priority rule and safety concerns led to the more sophisticated roundabout, now called the modern roundabout.

The success of this modern roundabout provoked a renewal of interest in the use of roundabouts worldwide. Modern roundabouts were reintroduced in France in 1972 and yield at entry imposed in 1983. They were incorporated into the French Highway Code in 1984. More than 1000 locations have been built each year. In Sweden, the new rule was introduced in the mid 1960s. Guidelines on capacity and design for intersections in rural areas were published in 1967, and for urban areas in 1973.

Contrary to Europe, roundabouts (traffic circles) in the US were not gaining any favor due to the bad reputations of old, large, merging and weaving, and locking roundabouts. The 1982 ITE Traffic Engineering Handbook devoted barely one page to traffic circles. The 1984 AASHTO 'Green Book', NCHRP Report 279 on channelization and the 1985 and 1994 Highway Capacity Manuals did not mention traffic circles (Todd 1988). Recently, however, some state DOTs are again interested in roundabouts. Maryland and Florida have been pioneers in introducing roundabouts in their states. FHWA is also interested in adopting the design guideline, which will be released in the next two years. The new Highway Capacity Manual, 1997, Chapter 10 has also included the proposed capacity formula for roundabouts.

## 2.2 TYPES OF ROUNDABOUTS

Based on California's Roundabout Design Guideline (Ourston and Doctors 1995), roundabouts can be classified into six types with differing applications.

**Normal Roundabout:** a roundabout with a one-way circulating roadway around a curbed central island 4 m (13 ft) or more in diameter.

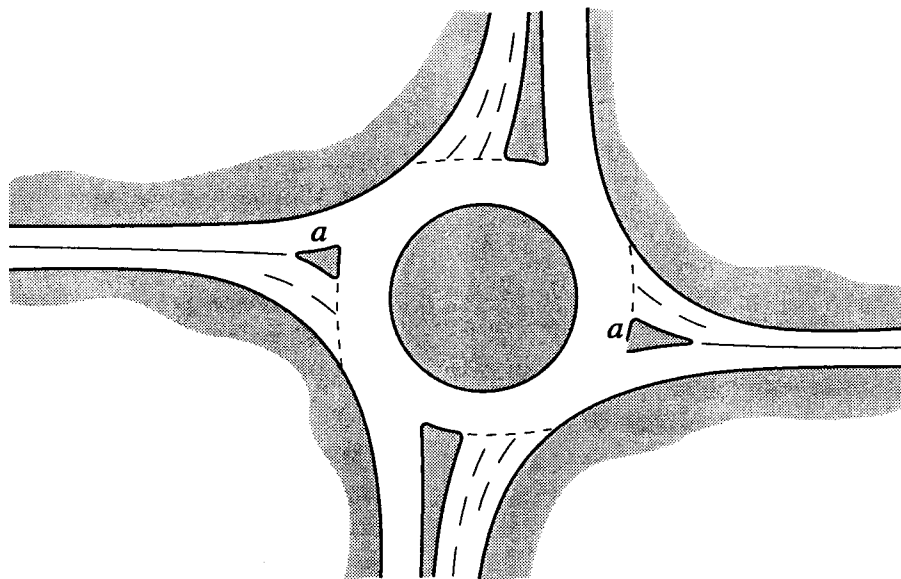

**Mini or Small Roundabout:** a roundabout with a one-way circulating roadway around a flush or slightly raised circular island less than 4 m (13 ft) in diameter.

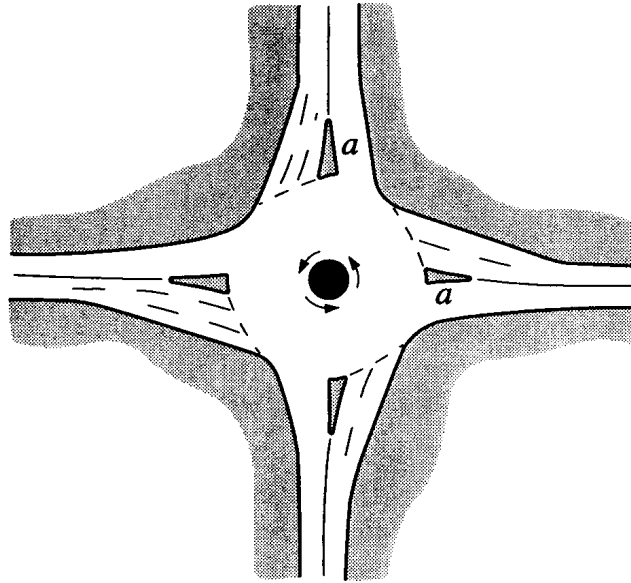

**Double Roundabout:** a single intersection with two normal or mini-roundabouts either contiguous or connected by a central link road or curbed island.

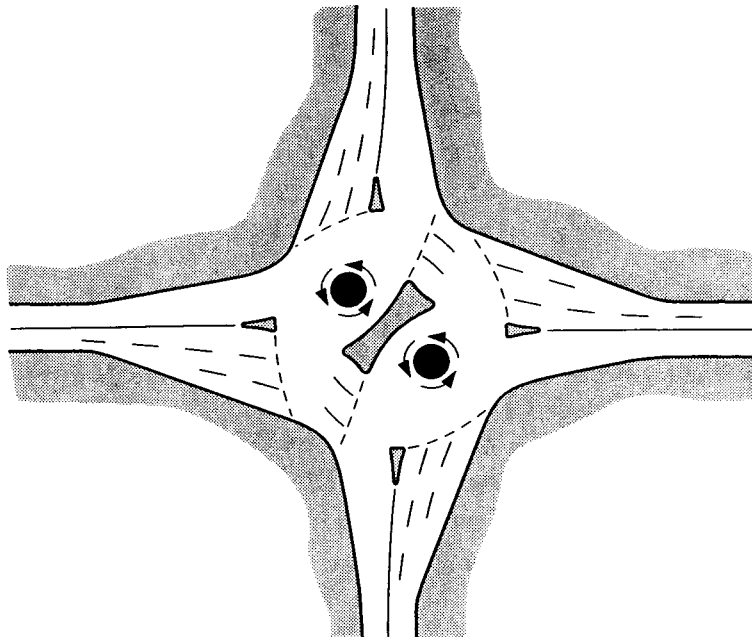

**Ring Junction:** a two-way circular ring road which is accessed by external spoke roads by way of 3-leg mini-roundabouts or T-intersections.

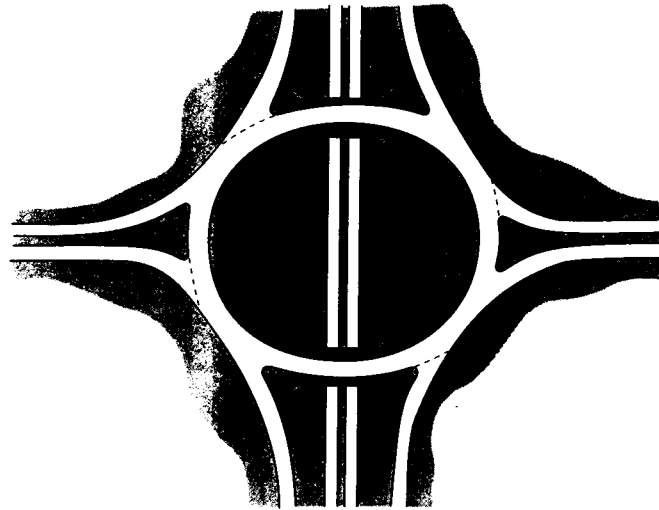

**Roundabout Interchange:** an interchange with one or more roundabouts. The most common types are freeway passing over or under one large roundabout which is joined by ramps and the cross street, and a roundabout at the ramps intersection with the cross street.

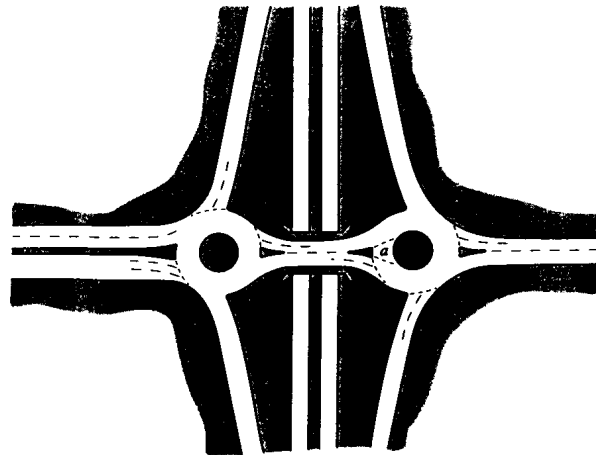

**Signalized Roundabout:** A roundabout in which traffic signals regulate one or more of the entries.

### 2.3 ADVANTAGES AND DISADVANTAGES

Table 2.2 presents the advantages and disadvantages of roundabouts (*Wallwork 1995*). Additional statements have been included for further consideration.



**Table 2.2: Advantages and Disadvantages Comparison**

Category	Advantages	Disadvantages
Safety	<ul style="list-style-type: none"> <li>- There are a reduced number of conflict points compared to an uncontrolled intersection.</li> <li>- Lower operational speeds yield less severe and fewer accidents.</li> <li>- Slower speeds because of intersection geometry reduce accidents.</li> </ul>	<ul style="list-style-type: none"> <li>- Since roundabouts are unfamiliar to the average driver in the US, there is likely to be an initial period where accidents increase.</li> <li>- Signalized intersections can preempt control for emergency vehicles.</li> </ul>
Capacity	<ul style="list-style-type: none"> <li>- Traffic <i>yields</i> rather than <i>stops</i>, often resulting in the acceptance of smaller gaps.</li> <li>- For isolated intersection, roundabouts should give higher capacity/lane than signalized intersections due to the omission of lost time (red and yellow) at signalized intersections.</li> </ul>	<ul style="list-style-type: none"> <li>- Where the coordinated signal network can be used, a signalized intersection will increase the overall capacity of the network.</li> <li>- Signals may be preferred at intersections that periodically operate at higher than designed capacities.</li> </ul>
Delay	<ul style="list-style-type: none"> <li>- The overall delay will probably be less than for equivalent volume signalized intersections (this does not equate to a higher level of service).</li> <li>- During the off-peak, signalized intersections with no retiming produce unnecessary delays to stopped traffic when gaps on the other flow are available.</li> </ul>	<ul style="list-style-type: none"> <li>- Drivers may not like the geometric delays which force them to divert their cars from straight path.</li> <li>- When queuing develops, entering drivers tend to force into the circulating streams with shorter gaps. This may increase the delays on other legs and the number of accidents.</li> </ul>
Cost	<ul style="list-style-type: none"> <li>- In general, less right-of-way is required.</li> <li>- Maintenance costs of signalized intersections include electricity, maintenance of loops, signal heads, controller, timing plans (roundabout maintenance includes only landscape maintenance, illumination, and occasional sign replacement).</li> <li>- Accident costs are low due to the low number of accidents and severity.</li> </ul>	<ul style="list-style-type: none"> <li>- Construction costs may be higher.</li> <li>- In some locations, roundabouts may require more illumination, increasing costs.</li> </ul>
Pedestrians and Bicyclists	<ul style="list-style-type: none"> <li>- A splitter island provides a refuge for pedestrians that will increase safety.</li> <li>- At low speed and low traffic volume, roundabouts should improve safety for bicyclists.</li> </ul>	<ul style="list-style-type: none"> <li>- A splitter island may cause difficulty to people using wheelchairs.</li> <li>- Tight dimensions of roundabouts create an uncomfortable feeling to bicyclists.</li> <li>- Longer path increases travel distances for both pedestrians and bicyclists.</li> <li>- Roundabouts may increase delay for pedestrians seeking acceptable gaps to cross.</li> </ul>

## 2.4 SITE LOCATIONS

Austroad design guideline (*Austroad 1993*) recommends for the following appropriate and inappropriate locations for roundabouts.

### 2.4.1 Appropriate Sites for Roundabouts

Roundabouts may be appropriate in the following situations:

- At intersections where traffic volumes on the intersecting roads are such that STOP or YIELD signs or the T intersection rule result in unacceptable delays for the minor road traffic. In these situations, roundabouts would decrease delays to minor road traffic, but increase delays to the major road traffic.

- At intersections where traffic signals would result in greater delays than a roundabout. It should be noted that in many situations roundabouts provide a similar capacity to signals, but many operate with lower delays and better safety, particularly in off-peak periods.
- At intersections where there are high proportions of left-turning traffic. Unlike most other intersection treatments, roundabouts can operate efficiently with high volumes of left-turning vehicles. Indeed, these left-turning vehicles contribute to roundabout operation as is illustrated in Figure 2.3.

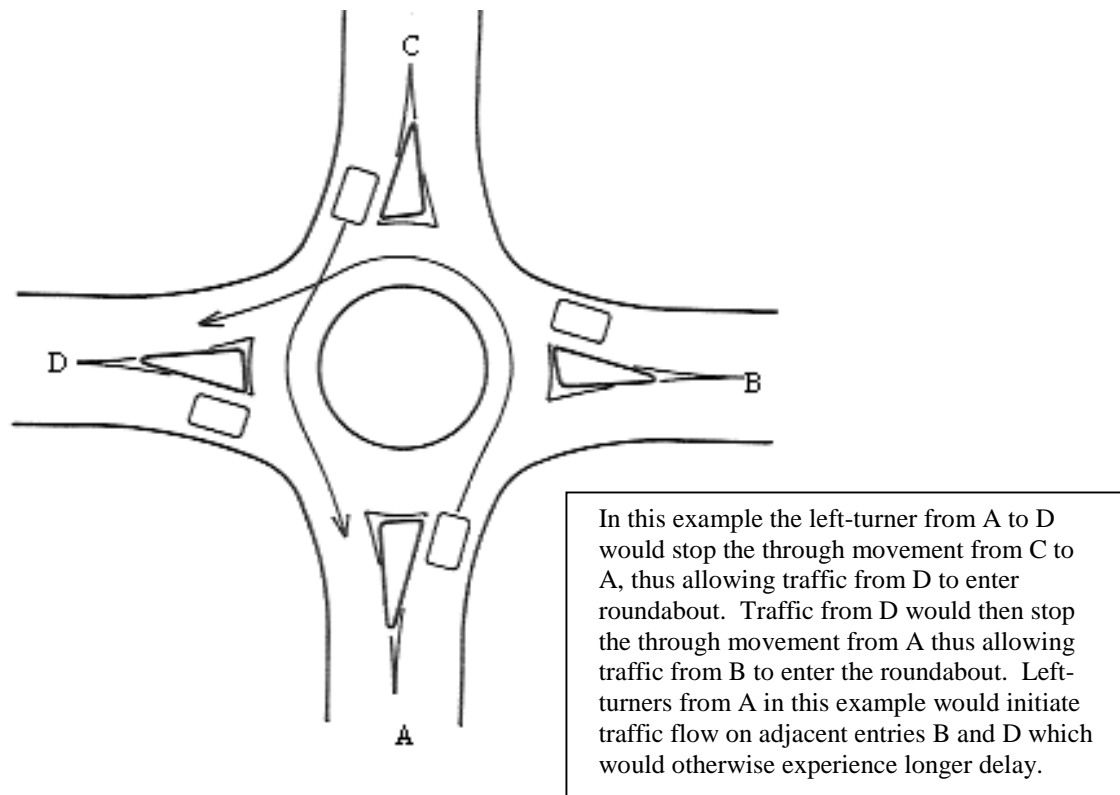

Figure 2.3: Roundabout Movements (*Austroroad 1993*)

- At intersections with more than four legs. If one or more legs cannot be closed or relocated, or some turns prohibited, roundabouts can provide a convenient and effective treatment. With STOP or YIELD signs, it is often not practical to define priorities adequately, and signals may be less efficient due to the large number of phases required (resulting in a high proportion of lost time).
- At cross intersections of local and/or collector roads where a disproportionately high number of accidents occur which involve either crossing traffic or turning movements. In these situations, STOP or YIELD signs may make little or no improvement to safety, and traffic signals may not be appropriate because of the low traffic volumes. Roundabouts, however, have been shown to reduce the casualty accident rates at local and/or collector road intersections.

- On local roads, and to a lesser extent on arterial roads, roundabouts can improve safety and neighborhood traffic management.
- At rural cross intersections (including those in high-speed areas) where there is an accident problem involving crossing or left turn (vs. opposing) traffic. However, if the traffic flow on the lower volume road is less than about 200 vehicles per day, consideration could be given to using a staggered T treatment.
- At intersections of arterial roads in outer urban areas where traffic speeds are high and left-turning traffic flows are high. A well-designed roundabout could have an advantage over traffic signals in reducing left turn opposed type accidents and overall delays.
- At T or cross intersections where the major traffic route turns through a right angle. This often occurs on highways in country towns. In these situations the major movements within the intersection are turning movements which are accommodated effectively and safely at roundabouts.
- Where major roads intersect at Y or T junctions, as these usually involve a high proportion of left turning traffic.
- At locations where traffic growth is expected to be high and where future traffic patterns are uncertain or changeable.
- At intersections of local roads where it is desirable not to give priority to either road.

## **2.4.2 Inappropriate Sites for Roundabouts**

Roundabouts may not be appropriate in the following situations:

- Where a satisfactory geometric design cannot be provided due to insufficient space or unfavorable topography or unacceptably high cost of construction, including property acquisition, service relocations etc.
- Where traffic flows are unbalanced with high volumes on one or more approaches, and some vehicles would experience long delays.
- Where a major road intersects a minor road and a roundabout would result in unacceptable delay to the major road traffic. A roundabout causes delay and deflection to all traffic, whereas control by STOP or YIELD signs or the T intersection rule would result in delays to only the minor road traffic.
- Where there is considerable pedestrian activity and due to high traffic volumes it would be difficult for pedestrians to cross either road. (This may be overcome by the provision of pedestrian crossing facilities on each leg of the roundabout).
- At an isolated intersection in a network of linked traffic signals. In this situation a signalized intersection linked to the others would generally provide a better level of service.

- Where peak period reversible lanes may be required.
- Where large combination vehicles or over-dimensional vehicles frequently use the intersection and insufficient space is available to provide for the required geometric layout.
- Where traffic flows leaving the roundabout would be interrupted by a downstream traffic control which could result in queuing back into roundabout. An example of this is a nearby signalized pedestrian crossing. The use of roundabouts at these sites need not be completely discounted, but they are generally found to be less effective than adopting signalized intersection treatment.

## **2.5 RECOMMENDATIONS FOR FURTHER CONSIDERATION**

Three types of roundabouts are recommended for usage in Oregon

### 1) Small Roundabout

This type of roundabout is most appropriate for an urban area where there are low vehicle speeds (40-55 km/h or 25-35 mph). It can effectively accommodate high volumes of both pedestrians and bicyclists. The size of the central island, entry, and exit are limited by the right of way. The design configuration should be based on safety concerns with potentially less benefit to capacity.

### 2) Normal Roundabout

The normal roundabout should be implemented first because it is the easily understood standard design and has potential for use in many locations. Normal roundabouts can accommodate high traffic volumes and low to moderate volumes of pedestrians and bicyclists. The design should balance between capacity and safety, and reflect vehicle approach speeds. A normal roundabout in a low speed urban environment is designed differently than a normal roundabout in a high speed rural environment.

### 3) Roundabout Interchange

Roundabout interchanges could be built at the connection with a state highway with appropriate speed conditions. Major concerns should be safety, the increase of capacity and the reduction of delay.

## 3.0 SAFETY OF ROUNDABOUTS

Numerous studies have reviewed issues related to the safety of roundabouts. This chapter summarizes safety studies in countries abroad and in the US. The summary of accident types at roundabouts from the observations by H.A Cedersund in Sweden is presented in Section 3.2 (*Cedersund 1988*). The existing accident models at roundabouts for both motorists and bicyclists are presented in Section 3.4.

### 3.1 SAFETY BENEFITS

Safety improvement is the most distinct advantage of roundabouts. Most areas that implement roundabouts experience an impressive impact on their accident record. Because of this remarkable reputation, some countries have converted many intersections into roundabouts. France, for instance, is building almost 1500 roundabouts a year (*Guichet 1997*). In the Netherlands, since the late 1980s, approximately 400 roundabouts have been built over a period of only six years (*Schoon and van Minnen 1994*).

Higher safety at roundabouts is due to the following:

- The smaller number of conflict points in some circumstances.
- The avoidance of left-turn accidents, which are the cause of most fatal or serious accidents at cross intersections.
- The simplicity of decision-making at the entry point.
- The slow relative speeds of all vehicles in the conflict area.
- The protection of pedestrians on splitter islands which provide a refuge and permit crossing one direction of traffic at a time.

### 3.2 TYPES OF ACCIDENTS AT ROUNDABOUTS

According to Swedish study (*Cedersund 1988*), accidents at roundabouts can be categorized into twelve types (see Figure 3.1):

- |                                   |                               |
|-----------------------------------|-------------------------------|
| 1) Collision with traffic island  | 7) Rear-end collision         |
| 2) Run-off outwards               | 8) Collision in approach      |
| 3) Run-off onto central island    | 9) Collision in exit          |
| 4) Rollover                       | 10) Bicycle or moped accident |
| 5) "Squeezing" during circulation | 11) Pedestrian accident       |
| 6) Collision in exit              | 12) Others                    |

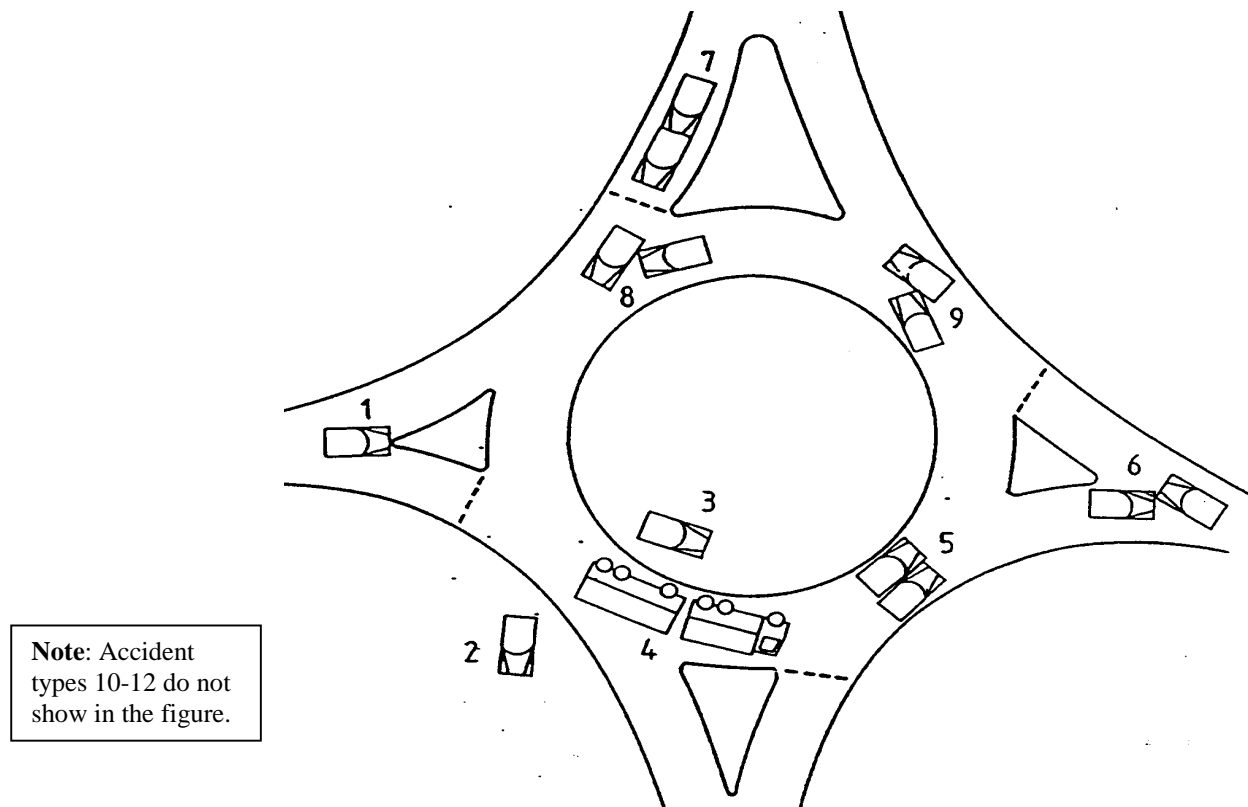

Figure 3.1: Different Types of Accidents in Roundabouts (*Cedersund 1988*)

### 3.3 ACCIDENT STUDIES

R.T. Tudge (*Tudge 1990*) studied accidents at roundabouts in New South Wales, Australia. Accident data from 230 roundabouts and 60 controlled intersections were obtained from 1981 to 1987. The study showed that there was a 50 percent overall reduction in accidents at roundabouts with a 63 percent reduction in fatal accidents, a 45 percent reduction in injury accidents and a 40 percent reduction in damage-only accidents.

In Germany, Birgit Stuwe (*Stuwe 1991*) at the Ruhr-University, Bochum, conducted a comparative study between roundabouts and other controlled intersections. Accident data from fourteen roundabouts and fourteen other controlled intersections were obtained. The study made comparisons under the criteria that the selected controlled intersection had to be situated in the immediate vicinity of the roundabouts. This provided equal or similar conditions for traffic parameters such as traffic volume and driver behavior. The reported data covered several years. The accident data was obtained from the files of police authorities.

The analysis indicated that the total number of accidents at roundabouts seemed to be higher than at intersections, but the severity of these accidents was lower.

Further investigation of these results by Stuwe revealed data from two distinct categories of roundabouts. First was the group of large roundabouts with an old design. That meant two-lane

entries with a curved approach resulting in small entry angles (angle between the tangents of the entry and the circulating roadway). These intersections had a high number of accidents. On the other hand, the group of modern single lane roundabouts with almost radial entrances and 28-35 m (92-116 ft) inscribed circle diameter had few accidents and almost no severe damage.

Table 3.1 shows the accident rate and the accident cost rate for these two groups of roundabouts in comparison to other controlled intersections.

**Table 3.1: Accident Rate and Accident Cost Rate (Stuwe 1991)**

	Roundabouts		Intersections	
	Accident Rate	Accident Cost Rate	Accident Rate	Accident Cost Rate
Older roundabouts/intersections with traffic signal	6.58	24.90	3.35	6.49
Newer roundabouts/intersections with traffic signal	1.24	4.67	1.00	11.96
All roundabouts/all intersections	4.40	16.66	2.76	19.29

Accident Rate = accidents per 1 million vehicles

Accident Cost Rate = Deutsche Marks per 1 million vehicles

During the time of study, three sites were rebuilt into roundabouts. A before-and-after comparison was conducted. These three new roundabouts had diameters between 28 and 35 m (92 and 116 ft). At all three sites, the total number of accidents as well as the number of serious accidents decreased. However, the sample size was too small to allow for statistically significant results. There were no accidents with serious injuries after the transformation and the number of serious damage-only accidents decreased as well. Slight damage-only accidents were the most frequent. The number of accidents decreased from 4 accidents per year at intersections to 2.4 accidents per year at roundabouts. The number of personal injury accidents decreased from 3.3 injuries per year at intersections to 0.5 injuries at roundabouts (see Figures 3.2 and 3.3).

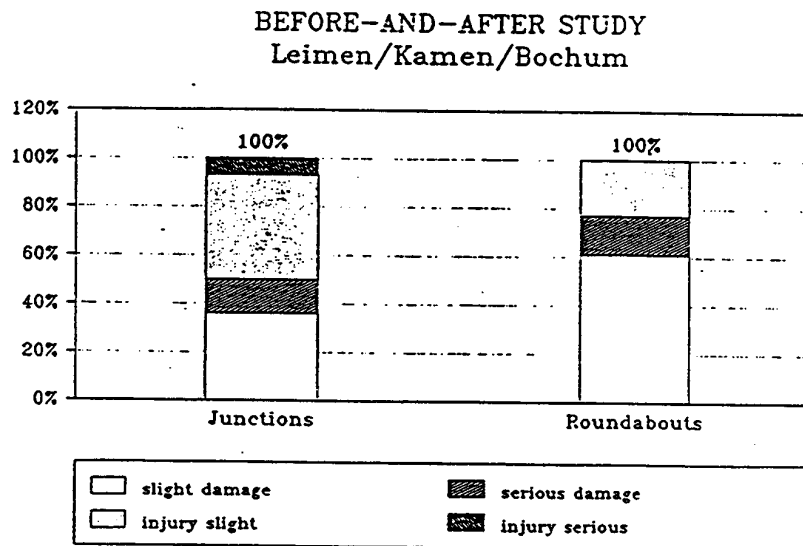

Figure 3.2: Absolute Number of Accidents per Year (Stuwe 1991)

**BEFORE-AND-AFTER STUDY  
Leimen/Kamen/Bochum**

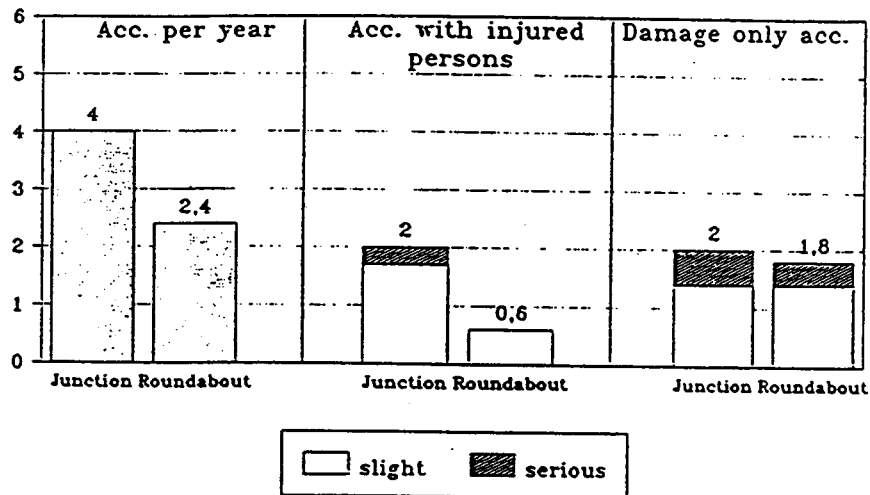

Figure 3.3: Portion of Accidents with Injured Persons or Damage Only (Stuwe 1991)

As previously mentioned, roundabouts in the Netherlands have become increasingly popular since the late 1980s. At the end of 1992, Chris Schoon and Jaap van Minnen (*Schoon and van Minnen 1994*) investigated 201 roundabouts. The study was focused on two subjects:

- 1) A before-and-after comparison of intersections and roundabouts at 181 locations.
- 2) A comparison of 201 roundabouts in the 'after' situation. Particular attention was devoted to engineering measures for cyclists and moped riders: a separate cycle path (Figure 3.4-Path), a cycle lane on the roundabout (Figure 3.5-Lane), or no specific engineering measures for cyclists (Figure 3.6-Non-lane).

The accident figures relate to the number of road accidents and casualties, classified according to severity, including accidents with material damage only. The years from 1984 to 1991 were inclusively considered.

In the before-and-after study, it was found that the number of accidents per intersection per year was reduced from 4.9 to 2.4. The number of casualties per year was also reduced, from 1.3 to 0.37. Consequently, the substitution of a roundabout for an intersection led to a 47 percent reduction in the number of accidents and a 71 percent reduction in the number of fatalities.

Other findings included:

- The conversion from a three-arm controlled intersection to a three-arm roundabout clearly offered less substantial accident reduction when compared to the conversion from a four-arm controlled intersection to a four-arm roundabout.
- The most improved sites were those converted from the old priority rule (give way to entering vehicles) to off-side priority (give way to circulating vehicles), with a decrease of



75.1 percent in fatalities. Contrarily, signalized intersections converted to roundabouts were shown to reduce accidents by only 2.7 percent at nine sites and were found to have a slight increase, 4 percent, in moped and cycle casualties.

- For cyclists' benefit, a 60 percent reduction of the total number of fatalities for 'Lane' and 'Non lane' and a 90 percent reduction for 'Path' roundabouts were found.

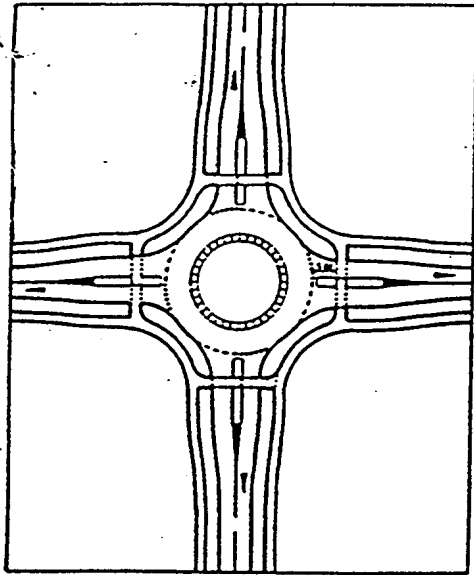

Figure 3.4: Path

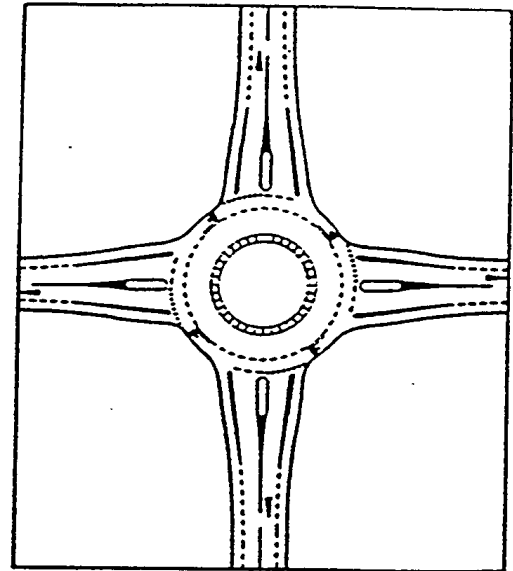

Figure 3.5: Lane

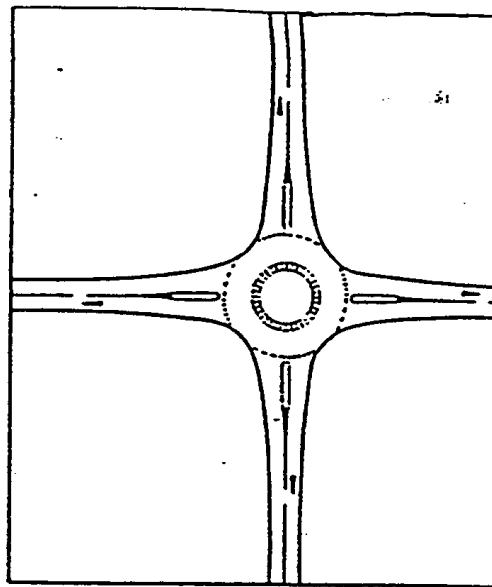

Figure 3.6: Non-Lane (*Schoon 1994*)

The “after study” was more focused on engineering measures for cyclists and moped riders. The following conclusions were reached:

- From a safety point of view, the roundabout with a cycle path was preferable. It was recommended that with intensities of at least 8000 motor vehicles per day and with a cycle volume of ‘some significance’, a separate cycle path should be provided.
- The average number of casualties per year progresses as the age of the roundabout increases. There was a marked fluctuation in victim statistics. The three-year study result was 0.19, 1.06, and 0.75 casualties per year respectively. A speculative explanation for the rise in the number of casualties per year was that during the initial ‘open to traffic’ period, unfamiliarity with roundabouts leads to cautious driving behavior, resulting in relative few casualties (introductory phenomenon). As familiarity increases, driving speeds also increase, leading to greater numbers of accidents.
- When compared to roundabouts with non-colored lanes, a red cycle lane on the roundabout resulted in a slightly diminished number of accidents per year, as well as fewer cyclist fatalities.
- Three-arm roundabouts with a 120-degree arrangement of approach roads led to a considerably larger number of accidents and casualties when compared to the standard 90-degree arrangement.

N. Lalani (*Lalani 1975*) studied 38 roundabouts of various diameters in the greater London area, UK. The 38 sites included in the study can be broken down as follows: twenty mini-roundabouts (1 to 4 m in diameter), nine small roundabouts (4.1 to 7.9 m in diameter), five large roundabouts and four double-mini roundabouts. The main findings from the study are as follows:

- Overall accidents fell by 39 percent compared to before having roundabouts; 30 percent for mini, 43 percent for small, 52 percent for large and 40 percent for double-mini roundabouts.
- Pedestrian accidents fell by 40 percent compared to before having roundabouts.
- Vehicle accidents fell by 39 percent compared to before having roundabouts. Since nose-to-tail and single-vehicle accident rates remained fairly stable, the fall could be attributed to accidents that were formerly cross-road and left-turner type.
- Fatal and serious vehicle accidents showed a 69 percent decrease and represented a fall from 17 percent to 10 percent of all accidents.
- Wet road accidents dropped by 51 percent (very few sites have been provided with anti-skid surfacing on approaches).
- Overall accidents at roundabouts constructed with a curbless island fell by only 23 percent, while nose-to-tail collisions rose by 60 percent and two-wheeled vehicle accidents rose by 7 percent.

In 1984, Maycock and Hall (*Maycock and Hall 1984*) studied the personal injury accidents at a sample of 84 four-legged roundabouts on main roads in the UK. The roundabout types included small roundabouts (with central island greater than 4 m diameter, with a relatively large ratio of inscribed circle diameter to central island size), conventional roundabouts (with relatively large central islands and usually with parallel unflared entries), and two lane roundabouts. The existing speed limits were 30-40 mph (50-65 km/h) and 50-70 mph (80-110 km/h). Their findings were:

- The average accident frequency (averaged over all roundabouts in the sample) was 3.31 personal injury accidents per year, 16 percent of which were classed as fatal or serious. The average accident rate per 100 million vehicles passing through the intersections was 27.5. Small roundabouts in 30-40 mph (50-70 km/h) speed limit zones had both higher accident frequencies and higher accident rates than other roundabout types.
- Analysis of accidents by accident type (entering-circulating accidents, approaching accidents, single-vehicle accidents and other accidents) showed that the pattern of accidents is different at small roundabouts than at roundabouts of conventional design. More than two-thirds of accidents at the former were of the entering-circulating type. By contrast, accidents at conventional roundabouts were relatively evenly divided between entering-circulating accidents, approaching accidents and single-vehicle accidents.
- A disaggregation of accidents by road user showed that bicyclists are involved in 13-16 percent of all accidents and motorcyclists in 30-40 percent. The accident involvement rates (per 100 million of road-user class) of two-wheeler riders were about 10-15 times those of car occupants. Pedestrian accidents represented about 4-6 percent of all accidents in this sample of roundabouts.
- An analysis of accidents by arm using a generalized linear modeling methodology was successful in relating the accident frequencies (accidents per year per arm) of the four accident types mentioned in the second bullet above, to traffic flow and roundabout geometry (see accident prediction section for more detail). Pedestrian accidents were related to vehicular and pedestrian flows only.
- The overall percentage error in the prediction of the mean accident frequency for a whole roundabout is about 20-25 percent. This error is of the same order as the error arising from the within site Poisson process after five to eight years worth of accident data has accumulated.

According to Leif Ourston (*Ourston and Doctors 1995*), in 1990, there were about 258,000 personal injury accidents in the UK. Of those, about 14,100 (5.5 percent) occurred at roundabouts. The proportion of fatal accidents at roundabouts was 0.43 percent, whereas 1.3 percent of all other intersection accidents and 2.8 percent of midblock accidents were fatal. This indicates how effective roundabouts are in reducing accident severity at intersections.

A study by Hall and Surl (*Ourston and Doctors 1995*) showed that on heavily traveled divided roads, for similar flows on both roads, a roundabout will generally have fewer accidents than a signalized intersection.

In the US, Flannery and Datta revealed favorable safety performance of roundabouts (*Flannery and Datta, Modern Roundabouts, 1996*). A before-and-after comparison of six US sites in Florida, Maryland and Nevada that were converted from T and cross intersections (both stop controlled and signalized) to roundabouts, revealed a reduction in accident frequency.

In Norway, the latest and most extensive risk analysis to date was carried out in 1990, based on accident data from 1985 to 1989 at 59 roundabouts and 124 signalized intersections (*Seim 1991*).

Risk is measured by accident rate (AR). AR is defined as the number of personal injuries reported to the police per million vehicles per year crossing the intersection:

$$AR = \frac{(PIR) * 10^6}{365 * (AADF) * P} \quad (3-1)$$

where: PIR = number of personal injuries reported to police  
 AADF = average annual daily flow (vpd)  
 P = duration of study period (year)

Table 3.2 shows the difference between the accident rate in roundabouts and intersections with traffic signals. Seim found that roundabouts with three arms are safest, but the difference between these and those with four arms is not substantial.

**Table 3.2: Accident Rates (Seim 1991)**

Number of Arms	Roundabouts	Traffic Signals
3	0.03 (0.05)*	0.05 (0.08)
4	0.05 (0.04)	0.10 (0.16)

\*Number in parentheses is from earlier studies

Intersections with priority signs and intersections with no form of control will normally have an accident rate between 0.10 and 0.30.

### 3.4 ACCIDENT RATES

As mentioned before, the Maycock and Hall study (*Maycock and Hall 1984*) found that accident rates at roundabouts can be predicted by a linear regression model. The Maycock formula has been used for the prediction of accidents at roundabouts in the UK. The formula predicts five different accident types:

- 1) entering/circulating vehicle-vehicle accidents
- 2) approaching vehicle-vehicle accidents
- 3) single-vehicle accidents
- 4) 'other' vehicle-vehicle accidents
- 5) pedestrian-vehicle accidents

The general equations giving the accident frequencies are:

Type 1 only:  $A = kQ_e^\alpha Q_c^\beta e^{\Sigma(b_i G_i)}$  (3-2)

Types 2-5:  $A = kQ^\alpha e^{\Sigma(b_i G_i)}$  (3-3)

where A is the accident rate (personal injury accidents per year per roundabout arm)  
 $Q_e, Q_c$  are entry and circulating flows (annual average daily totals)  
 Q is an annual average daily flow which depends on accident type  
 k,  $\alpha, \beta$  are constants which depend on accident type  
 $G_i$  are geometric parameters which depend on accident type  
 $b_i$  is the coefficient for  $G_i$

All parameters and geometric features for accident prediction are shown in Table 3.3 and Diagrams A and B (*adapted from Maycock and Hall 1984*).

**Table 3.3: Equations for the Prediction of Accident Frequencies at Roundabouts (Personal Injury Accidents per Year per Roundabout Arm (A)) (*Semmens 1985*)**

Accident type	Q	K	$\alpha$	$\beta$	$b_i$	$G_i$
1	-	0.052	0.7	0.4	-40 0.14 -0.007 -0.01 0.2 -1	$C_e$ , entry curvature e, entry width e and v, approach width correction $\theta$ , angle between arm $P_m$ (percentage motorcycles) Ratio Factor, $RF = 1/(1+\exp(4R-7))$ and $R = D/CID$
2	$Q_e$	0.0057	1.7	-	20 -0.1	$C_e$ e
3	$Q_e$	0.0064	0.8	-	25 0.2 -45	$C_e$ v $C_a$ , approach curvature
4	$Q_e, Q_c$	0.0026	0.8	-	0.2	$P_m$
5	$Q_p(Q_e + Q_{ex})$	0.029	0.5	-	-	

$Q_p$  and  $Q_{ex}$  are the annual average daily pedestrian and exit flow respectively

The geometric parameters included in Table 3.3 are defined as follows:

- (i) The entry path curvature ( $C_e$ ); in meters, is defined in terms of the 'shortest' straight-ahead vehicle path. Consider a vehicle making a straight through movement at the roundabout in the absence of other traffic. Construct a path 2 m wide with flowing curves representing the shortest path the vehicle could take through the roundabout keeping on its own side of the road but otherwise ignoring lane markings. The heavy line in Diagram A represents the locus of such a path. (Note: it is assumed that the path would start adjacent to the nearside curb). Now measure as  $C_e$  the maximum value of the curvature of this path occurring in the region of the entry (i.e. the reciprocal of the minimum value of R in meters - Diagram A). The sign convention is that the curvature is positive if deflection is to the left, and negative if the path deflects to the right.

(Note: a more comprehensive definition of entry path curvature is contained in the British Department of Transport's Departmental Standard--The Geometric Design of Roundabouts.)

- (ii) The entry width (e); in meters, is measured from the point P (Diagram A) along a line normal to the nearside curb.
- (iii) The approach half-width (v); in meters, is measured at a point in the approach upstream from any entry flare, from the road center marking to the nearside curb along a normal (Diagram A).

- (iv) The angle ( $\theta$ ) between the approach arm and the next arm clockwise; in degrees, is the angle subtended by projections of the relevant approach center lines as shown in Diagram A. If the approaches are curved then the tangents to the center lines at the entry point (P) are used for this construction.
- (v) Inscribed Circle Diameter (ICD); in meters, is the diameter of the largest circle that can be inscribed within the intersection outline (Diagram A). In cases of asymmetric intersection outlines (where a circle cannot conveniently be fitted within the design) a compromise value for ICD should be adequate.

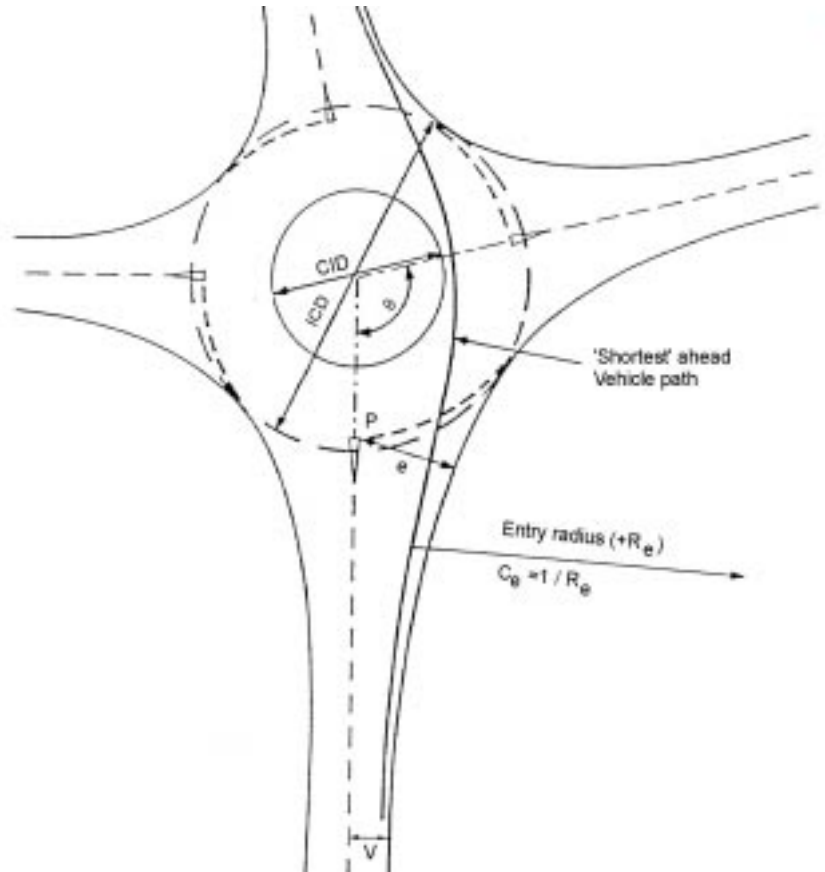

Diagram A

- (vi) Central Island Diameter (CID); in meters, is the maximum value in cases of non-circular islands. Asymmetry in the sample included in the study rarely exceeded 20 per cent.
- (vii) Approach curvature ( $C_a$ ); in per meter, is defined in terms of that section of the intersection approach road within the range of about 50 m (to be clear of the immediate entry geometry) to 500 m from the roundabout yield line.  $C_a$  is the maximum curvature (the reciprocal of the minimum radius in meters) of the bend nearest to the intersection within this section of the approach. Diagram B illustrates this parameter in two cases. The sign convention is that right hand bends (approaching the roundabout) are positive and left hand bends are negative. A straight approach has  $C_a = 0$ .

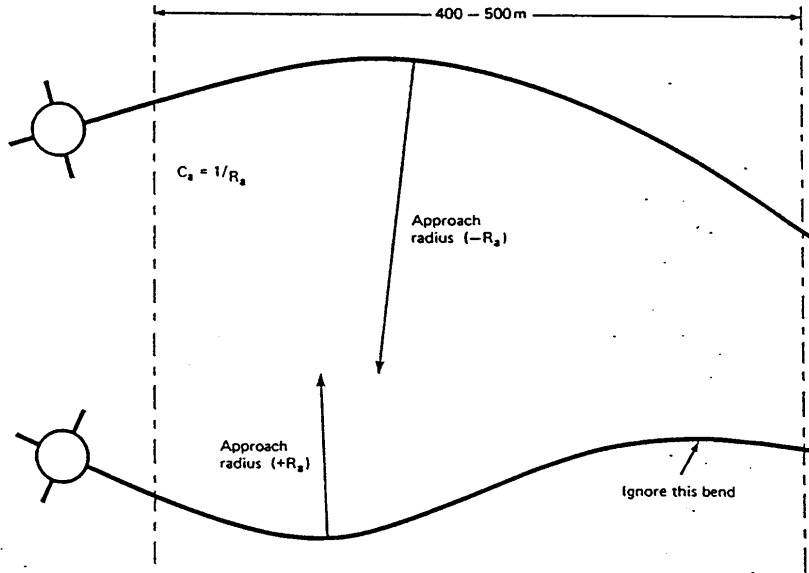

Diagram B: Illustrating Approach Curvature ( $C_a$ )

The French proposed two models for the prediction of roundabout accidents (*Guichet 1997*):

$$A = 0.15 * 10^{-4} * T_e$$

or

$$A = 0.24 * 10^{-6} * T_e^{1.4}$$

where  $T_e$  = Daily traffic in the roundabout (vpd).

In Sweden, a model was developed to predict the number of cycle accidents at roundabouts. This model is shown in Figure 6.8 (*Brude and Larsson 1997*):

$$CACCPERYEAR = 0.0000180^{0.52} \cdot TOTCYC^{0.65}$$

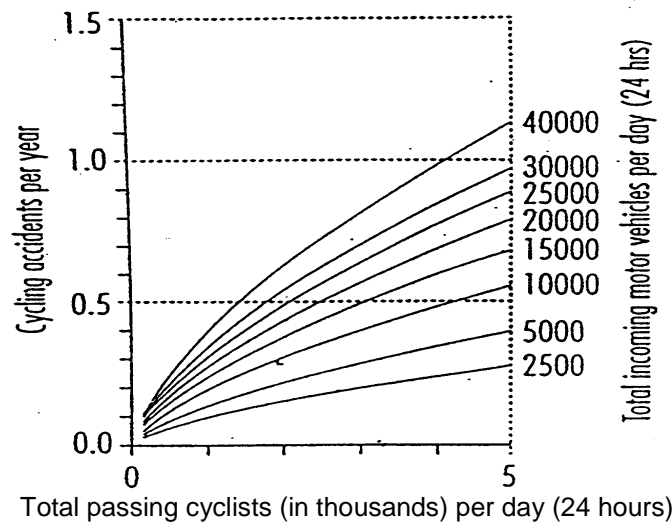

Figure 3.7: Predicted Number of Bicycle Accidents According to the VTI Model

where

CACCPERYEAR = the number of cycle accidents for both personal injury and damage  
per year

TOTINC = the number of various numbers of incoming motor vehicles per day

TOTCYC = the number of passing cyclists per day.

### **3.5 RECOMMENDATIONS FOR FURTHER CONSIDERATION**

Some conclusions can be drawn from the work summarized in this chapter:

- 1) There is an expected reduction of number of accidents and accident severity at roundabouts compared with other controlled intersections.
- 2) There is no clear evidence or study in pedestrian accidents at roundabouts and further investigation is recommended.
- 3) According to the study in the Netherlands, there are some benefits for bicyclists at roundabouts with a bicycle lane and mixed flow. Roundabouts with an exclusive bicycle lane are the safest for bicyclists. However, roundabouts with an exclusive bicycle lane may not be suitable for Oregon and further investigation is recommended.
- 4) The UK accident rate formula implies a relationship between geometry and accident rate.

There is a contradiction between safety of three-legged roundabouts and four-legged roundabouts. According to the Chris Schoon study, the conversion from a T intersection to a three-legged roundabout offers less substantial savings when compared to the conversion from a four-legged intersection to a four-legged roundabout. In contrast, Kjell Seim found that three-legged roundabouts are safest, but the difference between three-legged and those with four legs is not substantial.



## 4.0 PEDESTRIAN AND BICYCLIST CONSIDERATIONS

One of the objectives of roadway facilities is to provide mobility and safety for all road users, i.e., motorists, pedestrians, and bicyclists. However, providing safe mobility for pedestrians and bicyclists can be complex. This chapter reviews the findings regarding pedestrians and bicyclists from both roundabout design guidelines and bicycle design standards related to roundabouts.

### 4.1 PEDESTRIANS

Providing a balance between safety and capacity design concerns, roundabouts generally improve safety for pedestrians, bicyclists, and motorists. Operational speeds of vehicles in roundabouts are in the vicinity of 30 to 40 km/h (20 to 25 mph). As shown in Figure 4.1, lowering speeds will reduce the pedestrians' risk of death if hit by a motor vehicle. This implies that pedestrians will benefit from the existence of roundabouts.

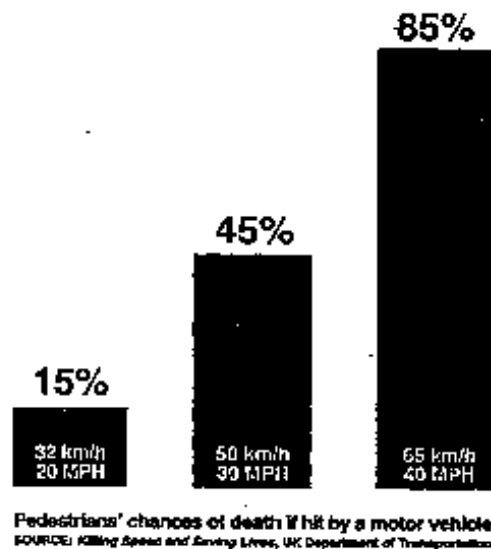

Figure 4.1: Relationship Between Speed and Pedestrian Fatality Rate (ODOT 1995)

Priority assigning between motorists and pedestrians should be a concern. Many guidelines, (i.e. Australia, Maryland, Florida) recommend no priority or pedestrian signal at roundabouts, but instead, encourage pedestrians to identify gaps in traffic and to cross when acceptable gaps are available. In this case, it is important to NOT give a false sense of security by painting pedestrian crossing lines across the entrances and exits of roundabouts.

The safety of this unmarked crosswalk recommendation is yet to be proven. Various studies have conflicting results concerning the safety of marked versus unmarked crosswalks. A current FHWA study is investigating this issue. Note that, using vehicle code definitions, there cannot

be a legal unmarked crosswalk at a roundabout, unlike at an intersection. In other words, a legal crosswalk at a roundabout must be marked (*Bared, Prosser and Tan Esse 1997*).

Priority crossing should be considered only where (*Austroroad 1993*):

- Pedestrian volumes are high.
- There is a high proportion of young, elderly, or infirm citizens wanting to cross the road.
- Pedestrians are experiencing particular difficulty in crossing and being delayed excessively.

Most guidelines recommend the location of a crosswalk at 1 to 2 car lengths from yield line (6 to 10 m (20 to 33 ft)). This will reduce decision-making problems for drivers and avoid the backup queue of vehicles waiting to exit roundabouts.

Austroroad also recommends further specific design considerations to enhance pedestrian safety at roundabouts including:

- Reduce vehicle approach speed by providing adequate deflection on each approach.
- Design splitter islands as large as the site allows.
- Prohibit parking on the approaches to the roundabouts to provide clear visibility.
- Provide street lighting to illuminate not only the circulating roadway but also the approaches.
- Locate signs and plants so as not to obscure pedestrians.

#### **4.1.1 French Design Practice for Pedestrians at Roundabouts**

In spite of certain preconceived notions, studies indicate that roundabouts are not more hazardous for pedestrians than other types of intersections. In fact, pedestrian crashes are rare, and mostly associated with multiple-lane entrances. But roundabouts cannot be considered “pedestrian-friendly,” because of the sense of insecurity when crossing a leg (though pedestrians’ awareness is heightened), and because large roundabouts create out-of-direction travel and sever the pedestrians’ normal path.

##### ***4.1.1.1 The Splitter Island***

The primary purpose of splitter islands in urban roundabouts is to provide a refuge, so pedestrians can cross a leg in two stages. The passage for pedestrians must be of the cut-through type. To “store” a pedestrian with a pram, for example, a minimum width of 2 m is recommended. But if circumstance don’t allow a 2 m (6.6 ft) width, a raised island as narrow as 0.8 m (2.5 ft) is still better than a simple painted line.

##### ***4.1.1.2 Crosswalk Placement***

The ideal solution would be to have all pedestrians follow the path created for them and to have all motorists yield to them. But in moving pedestrians too far from the roundabout, pedestrians will not tolerate the out-of-direction travel created. If the crosswalks are too close to the yield line, motorists will stop on it. Therefore the best solution is to place the crosswalk behind a stopped car, about 4-5 m (13-16.5 ft) from the

entry point. This is not an ideal solution, as one cannot force pedestrians to make even this slight a detour, and when a bus or truck is stopped, it will cover the crosswalk.

This position does have the advantage of allowing a pedestrian to cross behind a stopped car waiting to enter. The driver who stops to let a pedestrian cross at an exit lane does so outside of the roundabout, in an area perceived as more comfortable than in the circulating roadway.

#### **4.1.1.3 *Staggered Crosswalks***

In order to store a group of pedestrians on the splitter island, for example near a school, one should consider a staggered pedestrian crossing. In a staggered crossing, the crosswalks at the entry and exit legs are offset by a few meters. One rule must be adhered to: the crosswalk of the entrance leg must be further from the circulating roadway. If done the other way round, pedestrians will be crossing the island with their backs to the traffic they must cross.

When attempting to channel pedestrians to prohibit certain crossings with barriers or plantings, these should not obscure the motorists' view of the pedestrians, especially children, on the splitter island.

#### **4.1.1.4 *Pedestrians Crossing the Circulating Roadway***

On older, retrofitted traffic circles, or on urban large-diameter roundabouts, some pedestrian access to the central island may be allowable. But these crossings must be well controlled. Crosswalks should be placed right before the exits rather than right after the entrances. This is because drivers who are about to enter the roundabout are looking to their left for vehicles who have the right of way, and would not be looking to the right for pedestrians who may be crossing the circulating roadway.

Where the circulating roadway is big, the crossings may be controlled by signals. Here too, the crossing should be located before the exit.

## **4.2 BICYCLISTS**

In many countries, the reputation of roundabouts concerning safety for bicyclists and moped riders is questionable. In the UK, roundabouts are perceived by cyclists as hazardous sites to be avoided. At large roundabouts and gyratory systems, many cyclists are prepared to alter their route or get off and walk to avoid hazards (*Brown 1995*). Evaluation of this reputation infers that once bicyclists have entered a roundabout, they feel they are at risk. Questions of right of way for bicycle traffic and of separating or mixing flow should be carefully investigated.

### **4.2.1 Australia Recommendations**

Austroroad suggests that particular attention being given to the layout design of all roundabouts and bicycle paths in order to ensure that:

- Squeeze points on the approach, entry, and exit roadways are avoided.
- Adequate deflection and speed control is achieved on entry and through the roundabout.
- Inscribed diameter is not larger than necessary.
- Entry widths are chosen properly.
- Sight lines are not obstructed by landscaping, traffic signs or poles that could, even momentarily, obscure a cyclist.
- Adequate lighting is provided.

#### **4.2.2 The Netherlands Recommendations**

The road safety of bicyclists on roundabouts is highly dependent on volumes of motorized traffic. Based on the Netherlands Bicycle Facilities Design Manual (*CROW 1994*), roundabouts have a considerable capacity: peak volumes of 2,000 vehicles/day (vpd) in combination with an extensive number of cyclists can be processed virtually trouble free. Even on roundabouts with a vehicle volume of 8,000 to 10,000 vpd, accidents with cyclists and moped riders rarely occur, regardless of the presence of cycling facilities.

The Netherlands classifies bicycle facilities at roundabouts based on right of way for bicycle, separate or mixing path, and traffic volume, into four types as follows:

- Roundabouts with mixed flow when vehicle volume is not more than 8,000 vpd and approaching roads are not provided with bicycle lanes.
- Roundabouts with bicycle lanes when vehicle volume is not more than 10,000 vpd and approaching roads are not provided with bicycle lanes.
- Roundabouts with separate bicycle paths where bicyclists have right of way, when vehicle volume is more than 10,000 vpd.
- Roundabouts with separate bicycle paths where bicyclists have no right of way, when vehicle volume is more than 10,000 vpd.

- 

##### **4.2.2.1 Roundabouts with Mixed Flow**

For low volume roads with limited roadway width (less than 5 m (16 ft)), mixed flow or a bicycle lane is recommended. From the safety point of view there should be a minimum number of conflict points between motorized traffic and bicycle traffic. The roundabout with a mixed traffic flow has a relatively small number of conflict points; motor vehicles must stay behind cyclists if they wish to leave the roundabout. In this way problems of vehicle blindspots at roundabout exits are avoided. Priority is also given to through-bicycle traffic. However, motorists may feel uncomfortable because of priority sharing, and bicyclists become uncomfortable because of the confined geometry of the road and the uncertainty of whether or not motorists will give way (see Figure 4.2).

##### **4.2.2.2 Roundabouts with Bicycle Lanes**

On a roundabout with a bicycle lane, cyclists have right of way over traffic approaching or leaving the roundabout. When leaving, problems might occur as motorists cannot see cyclists in the blindspot. More accidents associated with right-of-way conflicts involving cyclists occur when vehicle volume is in between 8,000 to 12,000 vpd.

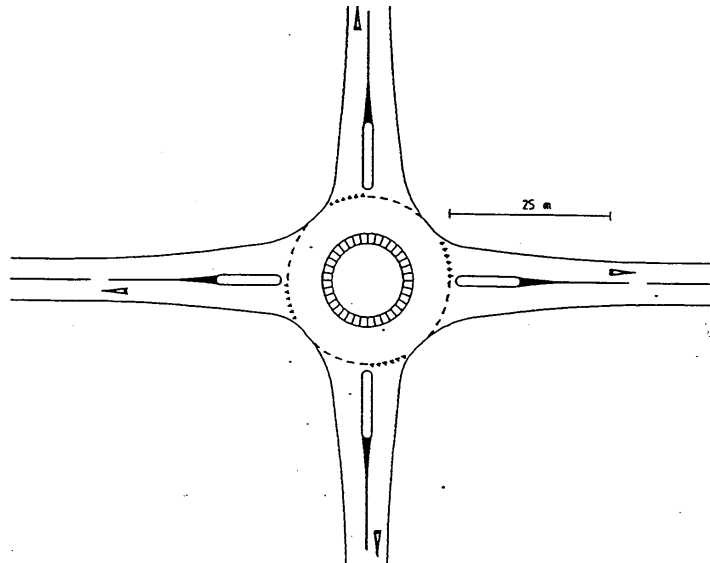

Figure 4.2: Roundabout for Mixed Traffic (*CROW 1994*)

Because of wide turning movements of trucks or swerving that caused cyclists to be hit, the Netherlands introduced physical separators called ‘hedgehogs’. As shown in Figure 4.3, these partitions consist of a narrow raised dividing curb (0.50 to 1.00 m wide (1.6 to 3.2 ft)). The hedgehogs are built at the entry, exit and at proper spacing along the roundabout. A condition for the introduction of hedgehogs on roundabouts and the connecting roads is that these raised constructions are highly visible and recognizable, even when covered with snow. Therefore the hedgehogs should be of sufficient length and clearly marked.

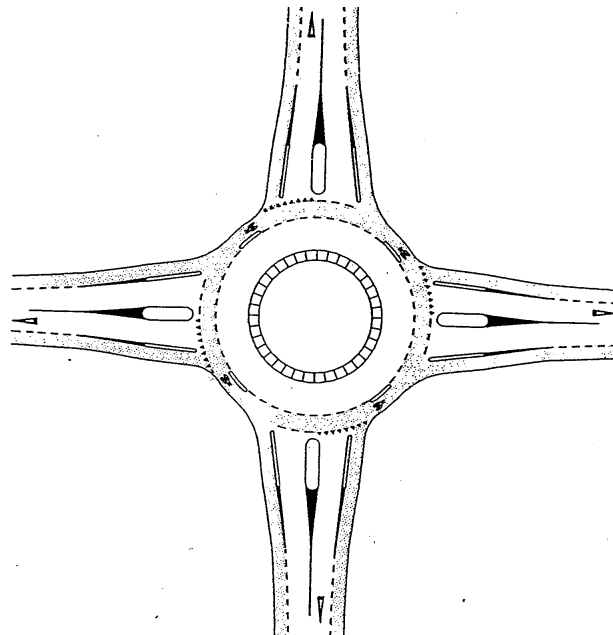

Figure 4.3: Roundabout with Cycle Lane (*CROW 1994*)

#### 4.2.2.3 Roundabouts with Separate Bicycle Paths for Bicyclists with Right-Of-Way

For this type, the bicycle path runs around the complete circumference equidistant from the circulating roadway (see Figure 4.4). Complete circumference of the bicycle path accentuates the fact that the bicycle path is an integral part of the roundabout, and that bicyclists while in the bicycle lanes have right of way over traffic approaching or leaving the roundabout, just as do cars on the roadway. The recommendation is for one way bicycle traffic, and a distance between circulating roadway and bicycle path of about 5 m (16.4 ft).

#### 4.2.2.4 Roundabouts with Separate Bicycle Paths for Bicyclists with No Right-Of-Way

The major difference with this type is the design of the bicycle crossing. The crossing is designed so that perpendicular bicycle-crossing over the approaching roads is achieved and the bicycle path continues in the outbending direction (see Figure 4.4). For these types of roundabouts, it is possible to allow two way bicycle traffic.

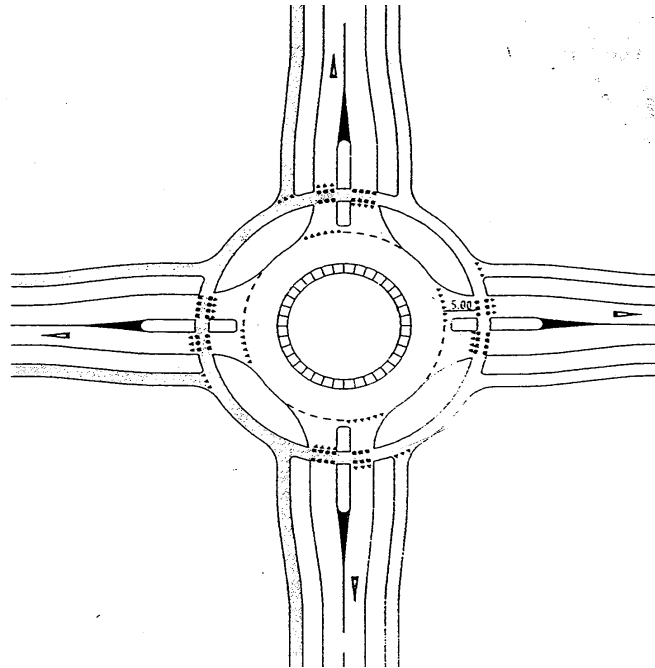

Figure 4.4: Roundabout with Separate-Lying Cycle-Track and Cyclists Having Right of Way (CROW 1994)

### 4.2.3 French Recommendations<sup>1</sup>

While roundabouts do have a good overall safety record, one must acknowledge the fact that bicycles are involved in 40% of crashes in urban environments. But they are involved in fewer crashes than in other types of intersections.

<sup>1</sup> This section is based on a translation of the French guidelines by Michael Ronkin, ODOT.

Most of the design recommendations of this guide (*CETRA 1996*) are drawn from crash analyses, and are therefore applicable to the safety of bicycles. On top of that, there are certain measures that can be taken specifically to improve bicyclists' safety and comfort.

#### **4.2.3.1      *Should Bicyclists be Isolated from Other Traffic?***

Currently, there is no evidence that bicyclists should have a separate path around the roundabout as a rule. But one shouldn't reject such a solution out of hand, even if it is observed that they aren't always used by cyclists and that they solve only certain problems.

A path for bicyclists around a roundabout cannot be provided in isolation - it must be the continuation of an existing path system.

#### **4.2.3.2      *Reintegration of Bicyclists into Traffic***

If a bicycle lane is not continued around the roundabout, it must be interrupted 15 to 20 m (46.5 to 66 ft) prior to the yield line. This is to prevent the last few meters, which should be reserved for bicyclists, from being infringed upon by vehicles, especially trucks, which are seeking to cut corners.

This is also true for a one-way bicycle-path - bicyclists should be integrated into traffic upstream, or the path can enter the roundabout with its own entrance. A two-way path, unless it continues around the roundabout, can be considered like and another leg, but of reduced size.

#### **4.2.3.3      *Bike Path***

A bike path on the outer perimeter of the circulating roadway can be considered under the following circumstances:

- On medium sized roundabouts (>40 m outside diameter);
- As a continuation of a path on both ends of the intersection;
- Where there are no entrance or exit legs with more than two lanes.

Crossings of the legs will have to be made in two stages, which requires sufficiently large splitter islands. Right of way cannot be assigned to bicyclists without major risks. Crossings can be adjacent to pedestrian crosswalks, but always on the inside, towards the roundabout.

#### **4.2.3.4      *Grade Separation for Bicyclists***

A heavily used path, running through a high-capacity roundabout, can be a candidate for grade separation. Though rare in France, this type of treatment is common in other countries.

#### **4.2.3.5**      *Bike Lanes*

A bike lane can be provided on the circulating roadway, under the following circumstances:

- As a continuation of a one-way bike lane on both ends of the intersection
- On smaller roundabouts, but larger than 30 m (100 ft) outside diameter (anything smaller will encourage trucks to encroach on the bike lane).

The bike lane should be 1.5 to 2 m (5 to 6.6 ft) wide around the ring. It should be separated from other traffic with a line, or painted a different color. It can be beneficial to separate bicyclists from other traffic at the entrances and exits with a small raised island.

#### **4.2.3.6**      *Motorcycles*

The accident rate for motorcycles at roundabouts is abnormally high. No design features can be used to effectively reduce crashes due to excessive speeds. It is possible to reduce the severity of such accidents by removing fixed objects, especially on the central island.

### **4.3 RECOMMENDATIONS FOR FURTHER CONSIDERATION**

For the implementation plan in Oregon, some concerns need to be addressed or further study may be necessary to address the following pedestrian and bicyclist issues:

- 1) Identifying right-of-way between motorists and pedestrians.
- 2) Using marked or unmarked crosswalks.
- 3) Establishing the site criteria where roundabouts may be inappropriate for pedestrians and bicyclists.
- 4) Determining the proper location of crosswalks.
- 5) Incorporating the needs of impaired pedestrians.
- 6) Determining the appropriate size of splitter islands.
- 7) Establishing recommendations for bicycle lanes and exclusive bicycle paths.

Since one of the ODOT policies is to encourage walking and bicycling in Oregon, it is important for a future design guideline to provide a balanced design between road capacity and pedestrian and bicyclist safety.



## 5.0 GEOMETRIC DESIGN OF ROUNDABOUTS

According to the capacity study of roundabouts in the UK, geometric elements of roundabouts play an important part in the efficiency of roundabout operational performance. Good design will improve not only capacity but also safety, which is a major concern for road design. Basic elements for design considerations of roundabouts are:

- Design Vehicles
- Design Speed
- Sight Distance
- Deflection
- Central Island
- Circulating Width
- Inscribed Circle Diameter
- Entry and Exit Design
- Splitter Island
- Superelevation and Drainage
- Pavement Markings
- Signing
- Lighting
- Landscaping

Figure 5.1 illustrates the major geometrical features of a modern roundabout.

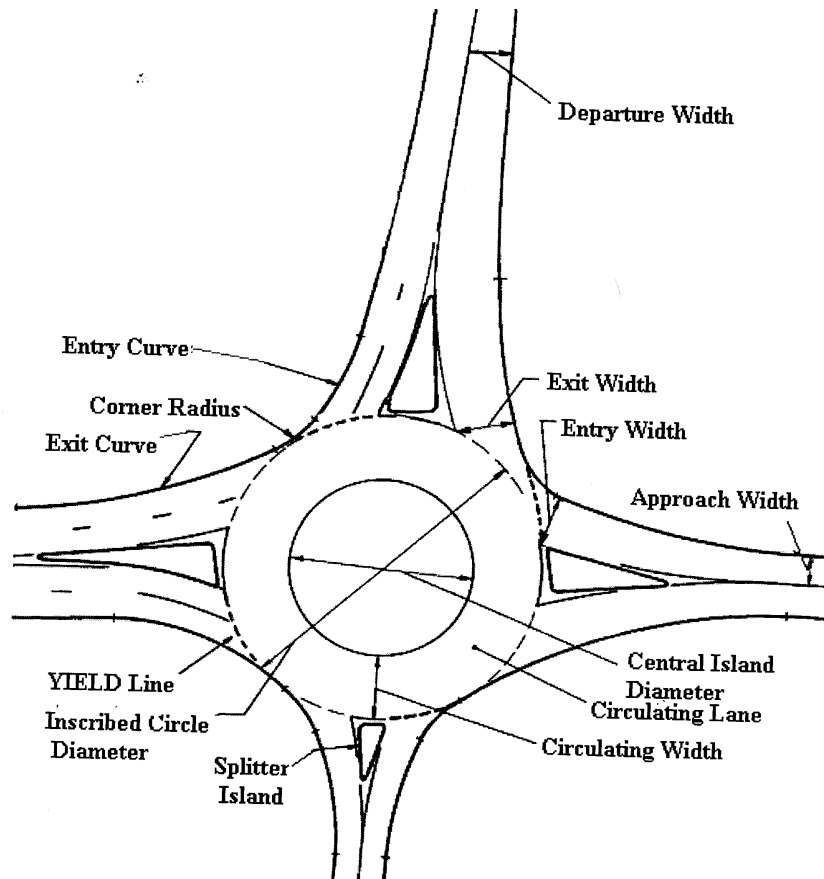

Figure 5.1: Geometric Elements of a Roundabout (*Adapted from Austroad 1993*)

This chapter summarizes and compares the geometric details of modern roundabouts in some existing design guidelines. For the purpose of this report, three US design guidelines (Florida, Maryland and California), and the Australian design guideline are discussed. Austroad is included because it is the most complete design guideline to date, and many parts are used as a reference within the three state design guidelines. Table 5.1 compares the four guidelines for some of the roundabout elements and further details are explained in the next sections (*Florida 1996; Maryland 1995; Ourston and Doctors 1995; Austroad 1993*). Additional excerpts from French design guideline are also included in the discussion (*CETRA 1996*).

**Table 5.1: Comparison of Design Guidelines**

	<b>Maryland</b>	<b>Florida</b>	<b>California</b>	<b>Austroad 1993</b>
Design Vehicle	WB 50	WB 15	See Figure 5.2	N/A
Design Speed	25-30 mph (40-50 km/h)	40-50 km/h	Varied	50 km/h
Sight Distance	Achieving 3 criteria (see text)	-Stopping Sight Distance -Gap Acceptance Sight Distance	-Stopping Sight Distance -Approaching Sight Distance	Achieving 3 criteria (see text)
Maximum radius of Curvature	430 ft (130 m)	100 m (330 ft)	100 m (330 ft)	100 m (330 ft)
Circulating Width	1.0-1.2 times the maximum entry width	1.0-1.2 times the maximum entry width	1.0-1.2 times the maximum entry width with maximum width at 15 m (or 49 ft)	See Table 5.6
Maximum Inscribed Circle Diameter	100 ft (30 m)	30 m (100 ft)	29-91.4 m (95-300 ft)	N/A
Entry width	11-15 ft (3.5-4.5 m)	4.2 m (14 ft)	> 3 m (10 ft)	3.4-4.0 m (11-13 ft)
Splitter Island				
-Width at Crossing	N/A	1.8 m (6 ft)	N/A	2.4 m (8 ft)
-Area	N/A	10 m <sup>2</sup> (108 ft <sup>2</sup> )	N/A	8-10 m <sup>2</sup> (86 to 108 ft <sup>2</sup> ).
Cross slope	0.025 to 0.03	0.02	0.02	0.025 to 0.03
Yield line (width-length-gap)	8" or 16"-3'-3' 200 or 400-900-900 mm	200-450-450 mm (8"-18"-18")	300 mm-1 m-1 m (12"-39"-39")	300-600-600 mm (12"-24"-24")

## 5.1 DESIGN VEHICLE

Roundabouts should provide a turning path for the largest vehicles expected to use the facility in significant numbers. Special designs such as truck aprons should be used as appropriate. Design vehicles of special size or purpose, such as emergency vehicles, must also be taken into consideration. Special care must be taken to ensure that existing or anticipated bus routes are accommodated in the design of a roundabout on state or local roads.

## Design Vehicles

**STAA truck.** Roadways should be wide enough for the STAA truck, stipulated in the Surface Transportation Assistance Act of 1982 (STAA), on all roundabouts in new interchanges on the National Network and on routes leading from the National Network to designated service and terminal points. On rehabilitation projects they should be wide enough for STAA trucks at interchanges proposed as service or terminal access points. In some cases, factors such as cost and right of way may indicate widths only large enough for the California truck.

**California truck.** Roadways should be wide enough for the California truck on highways not on the National Network.

**Bus.** At intersections where truck volumes are light or where the predominant truck traffic consists of mostly 3-axle and 4-axle units, bus roadway widths may be used. The wheel paths will sweep a greater width than 3-axle delivery trucks and smaller buses such as school buses, but a slightly lesser width than that of a 4-axle truck.

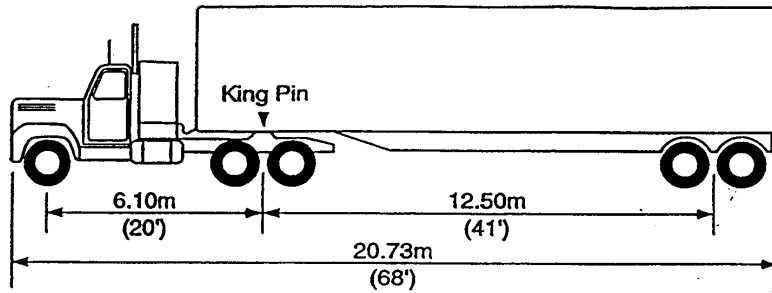

1 - STAA Design Vehicle

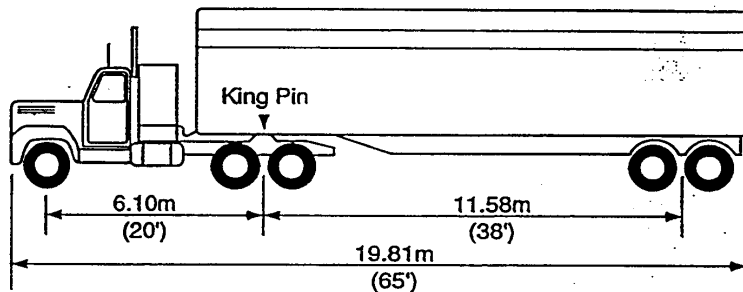

2 - California Design Vehicle

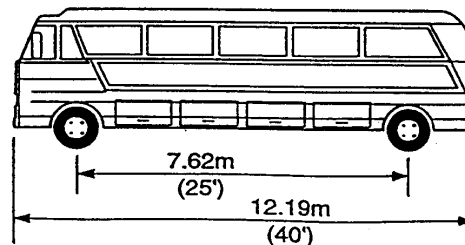

3 - Bus Design Vehicle

Figure 5.2: Design Vehicles for California (Ourston 1995)

## 5.2 DESIGN SPEED

One of the keys to the demonstrated success of roundabouts is the improvement in safety. Roundabouts have very low accident and injury rates. This is because roundabouts are inherently designed for low speeds. The design speed of roundabouts should be around 40-50 km/h (25-30 mph).

## 5.3 SIGHT DISTANCE

Visibility is an important concern in the design of roundabouts. Each state has different policies which address sight distance for stopping, gap acceptance and approaches, as summarized in Table 5.1. The differences are described below.

### 5.3.1 Australia and Maryland

Australia and Maryland use the same design procedures for sight distance. Three criteria are applied to evaluate the required sight distance.

#### 5.3.1.1 Criterion 1

The alignment on the approach should be such that the driver has a good view of the splitter island, the central island and the circulating roadway. Adequate approach stopping sight distance should be provided to the yield lines and, as an absolute minimum, to the nose of the splitter island. Table 5.2 indicates the required approach sight distances.

**Table 5.2: Approach Sight Distance (ASD) (Maryland)**

Approach Speed		Stopping Distance	
(mph)	(km/h)	(ft)	(m)
25	(40)	98	(30)
31	(50)	131	(40)
37	(60)	180	(60)
43	(70)	230	(70)
50	(80)	344	(110)
56	(90)	426	(140)
62	(100)	525	(170)
68	(110)	623	(200)
75	(120)	754	(250)

\*measured 4.0 ft to zero

#### 5.3.1.2 Criterion 2

A driver, stationary at the yield line, should have a clear line of sight to approaching traffic entering the roundabout from an approach immediately to the left, for at least a distance representing the travel time equal to the critical acceptance gap. A critical value of five seconds, based on an entry speed of 30 mph (50 km/h) and a distance of 225 feet (70 m), would be typical for arterial road roundabouts operating with low circulating flows. At sites with higher circulating flows or in local streets, the Criterion 2 sight distance could be based on a critical gap of four seconds.

The Criterion 2 sight distance should also be checked with respect to vehicles in the circulating roadway having entered from other approaches. The speed of these vehicles can be expected to be considerably less than 30 mph (50 km/h) and the corresponding sight distance to them (e.g. across the central island) should be based on a critical gap of four to five seconds. This represents a distance much less than 225 ft (70 m) because of the low circulating speed of these vehicles. This is illustrated in Figure 5.3.

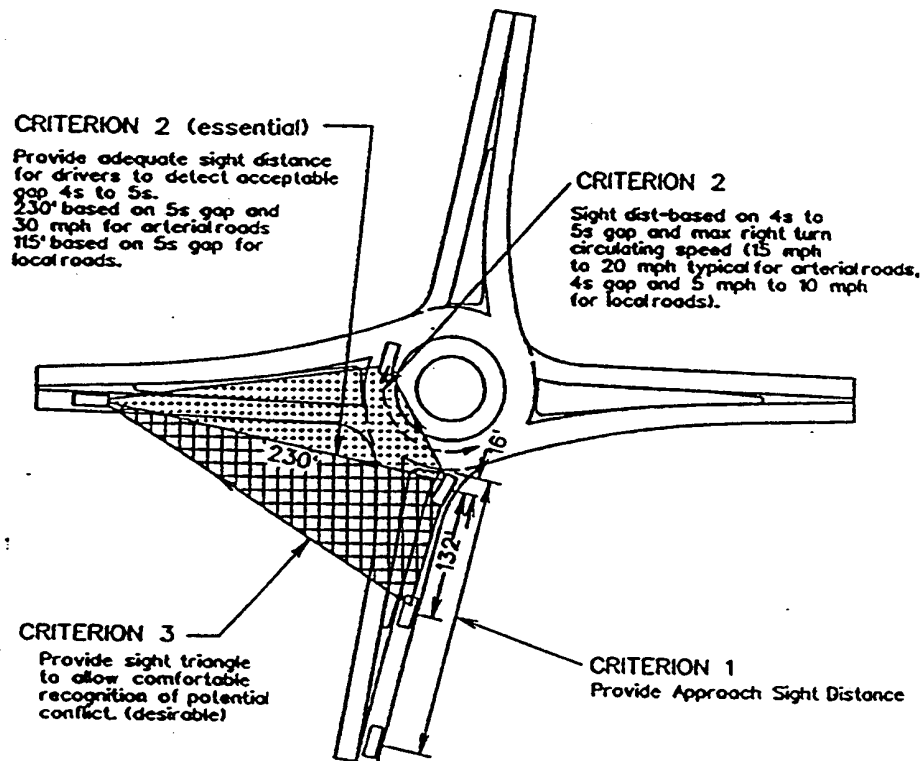

Figure 5.3: Sight Distance Requirements (Maryland 1995)

### 5.3.1.3 Criterion 3

Drivers approaching the roundabout should be able to see other entering vehicles well before they reach the yield line. The 125-225 ft sight triangle (40-70 m) shown in Figure 5.3 allows an approaching driver, slowed to 30 mph (50 km/h), enough time to stop and avoid a vehicle driving through the roundabout at 30 mph. It is desirable that this sight triangle be achieved, although in urban areas it may not always be possible. At roundabouts, the speed of vehicles is more controlled in the circulating roadway than on the approaches, and if Criterion 3 sight distance is available to an approaching driver then any circulating driver in this zone would also be able to see an approaching vehicle.

Note that within the zone subject to Criteria 2 and 3, it is acceptable to allow momentary sight line obstructions such as poles, sign posts and narrow tree trunks.

## 5.3.2 Florida

The Florida standard gives design values close to those of Austroad with some modifications that are appropriate for the local condition. Four types of sight distance requirements are given.

### 5.3.2.1 Stopping Sight Distance

The approach to the roundabout should be aligned so that the driver has a good view of the splitter island, the central island and preferably, the circulating roadway. Adequate approach stopping sight distance should be provided to the yield line.

### 5.3.2.2 Gap Acceptance Sight Distance

There are two geometric aspects associated with gap acceptance sight distance. Sight distance external to the inscribed circle for other vehicles approaching the roundabout in the roadway to the left, and sight distance within the inscribed circle for vehicles already in the circulating roadway. The geometric aspects of both of these sight distance requirements are illustrated in Figure 5.4.

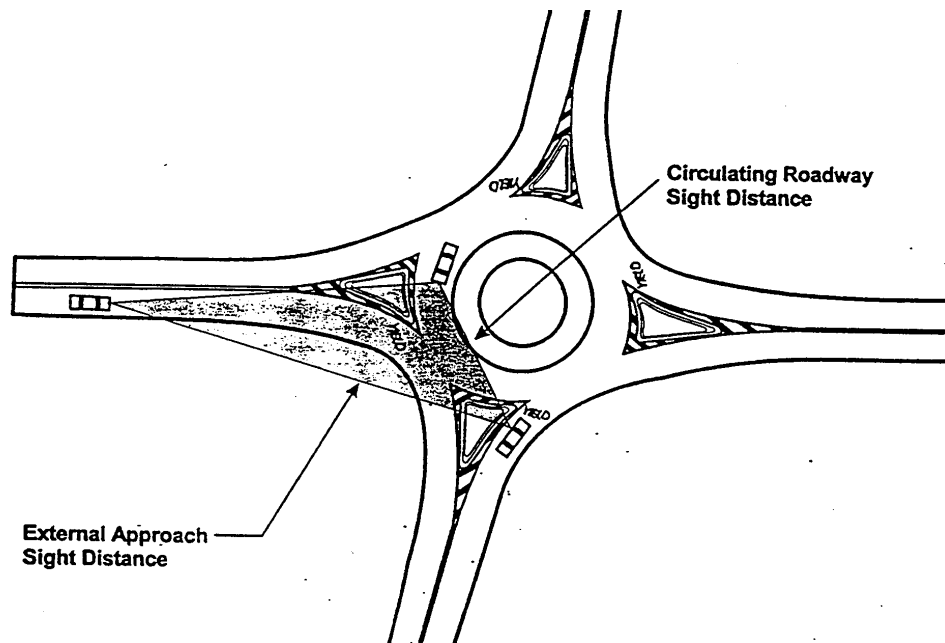

Figure 5.4: Gap Acceptance Sight Distance (Florida 1996)

#### 5.3.2.2.1 External Approach Sight Distance

A driver who is approaching the yield line should have a clear line of sight to approaching traffic entering the roundabout from an approach immediately to the left, for at least a distance representing the travel time equal to the critical gap. A minimum distance is 70 m (230 ft).

#### 5.3.2.2.2 Circulating Roadway Sight Distance

Gap acceptance sight distance should be checked with respect to vehicles in the circulating roadway having entered from other approaches. The speed of these vehicles can be expected to be 40 km/h (25 mph) or less and the corresponding sight distance to them (e.g. across and to the left of the central island) should be

based on a critical gap of five seconds. This could represent a distance less than the external approach sight distance because of the low circulating speed of these vehicles.

### 5.3.3 California

California uses the TD 9/81 UK Highway Link Design Standard for the sight distance specification. Stopping and approaching sight distances are given in Tables 5.3 and 5.4.

**Table 5.3: Stopping Sight Distance** (*Ourston 1995*)

Design Speed	(km/h)	50	60	70	85	100	120
	(mph)	31	37	43	53	62	75
Stopping Sight Distance							
Desirable Min.	(m)	70	95	125	165	225	300
	(ft)	230	312	410	541	738	984
Absolute Min.	(m)	50	70	95	125	165	225
	(ft)	164	230	312	410	541	738

**Table 5.4: Approaching Sight Distance** (*Ourston 1995*)

Inscribed Circle Diameter		Sight Distance	
(m)	(ft)	(m)	(ft)
<40	<131	Whole Intersection.	Whole Intersection.
40-60	131-197	40	131
60-100	197-328	50	164
>100	>328	70	230

## 5.4 DEFLECTION

The single most significant feature of a roundabout design is adequate entry, through, and exit deflections. Adequate deflection will facilitate safe roundabout operation. Adjusting the geometry of the entry and exit lanes to achieve the proper deflection will ensure the necessary reduction in speed. The following factors should be taken into consideration:

- Alignment of the entry road in conjunction with the shape, size and position of the approach splitter island;
- Provision of a suitable size and position of the central island; or
- Design of the roundabout with a staggered alignment between any entrance and exit.

Vehicle deflection is controlled by entry and exit radius, and the size of central island or central island radius. Australia, Maryland and Florida provide similar considerations with some modifications for their local conditions.

### 5.4.1 Deflection at Roundabouts with One Circulating Lane

The maximum desired “design speed” is obtained if no vehicle path (7 ft for Maryland, 1.8 m for Florida, and 2 m for Australia) has a radius greater than 100 m (430 ft for Maryland) (see Figure 5.5).

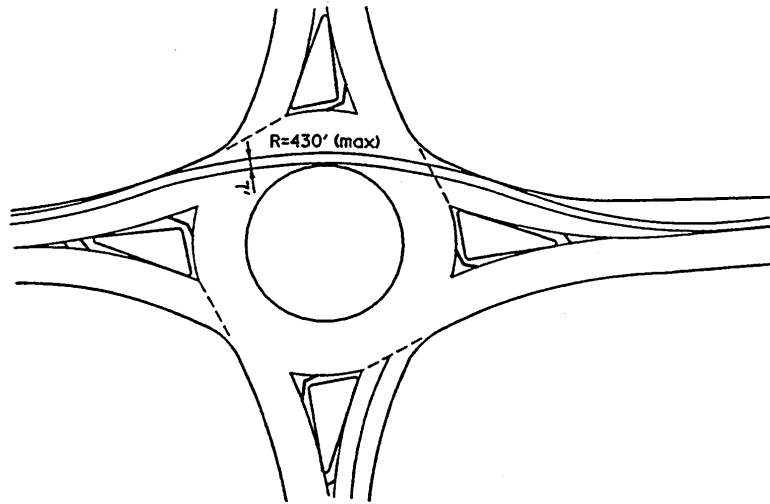

Figure 5.5: Deflection Criteria for a Single Lane Roundabout (*Maryland 1995*)

This radius of curvature was computed by the equation:

$$R = \frac{V^2}{127(e+f)} \quad (5.1)$$

with vehicle speed of 50 km/h (30 mph for Maryland), no superelevation ( $e=0$ ), and coefficient of side friction,  $f$ , of 0.2.

Maryland also gives various deflections relative to design speed based on the equation above.

**Table 5.5: Deflection Curve Radii** (*Maryland 1995*)

Design Speed (mph) (km/h)		Deflection Curve(ft) (m)	
12	(20)	60	(20)
15	(25)	100	(30)
20	(30)	180	(60)
25	(40)	290	(90)
30	(50)	430	(120)

#### 5.4.2 Deflection at Roundabouts with Two or Three Circulating Lanes

It is more difficult to achieve the recommended deflection for multi-lane roundabouts than for single lane roundabouts. Where this is the case, it is acceptable for the deflection to be measured using a vehicle path illustrated in Figure 5.6. It differs from that used in single lane roundabouts in that the fastest (maximum radius) vehicle path is assumed to start in the right entry lane, cutting across the circulating lanes and passing no closer than 1.5 m (5 ft for Maryland) to the central island before exiting the roundabout in the right lane.



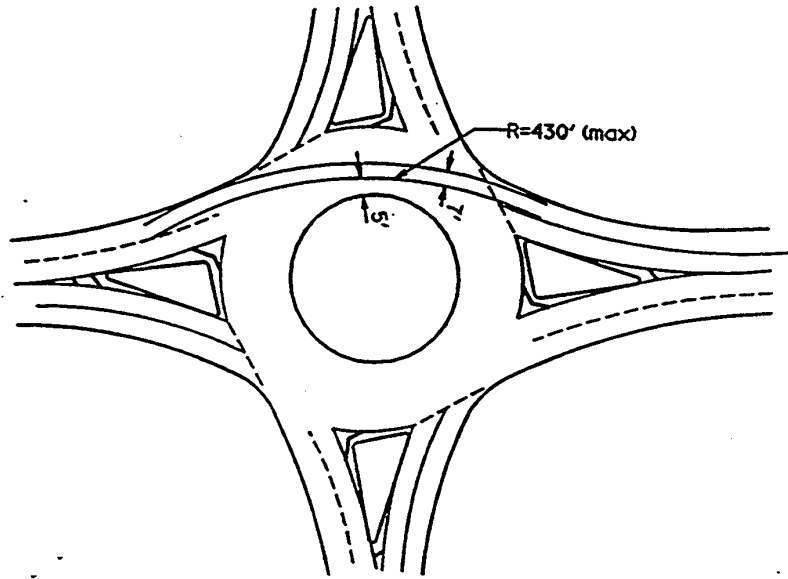
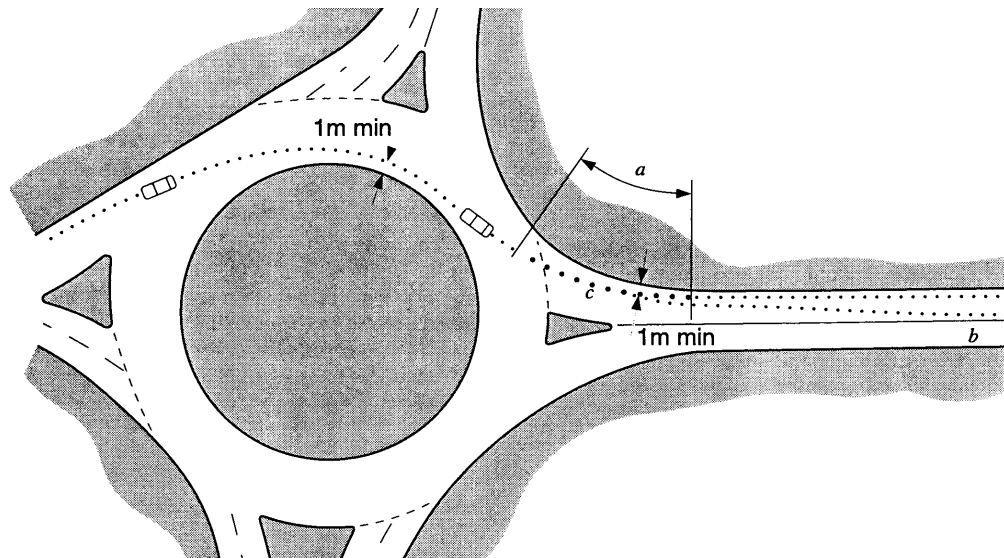

Figure 5.6: Deflection Criteria for a Multi-lane Roundabout (*Maryland 1995*)

California gives a similar standard with more details for constructing and measuring the path curvature. The curvature is shown in Figure 5.7 and the radius is limited to 100 m (328 ft).



LEGEND

- a* The radius should be measured over a distance of 20 to 25 meters (66 to 82 ft). It is the minimum which occurs along the approach entry path in the vicinity of the yield line but not more than 50 meters (164 ft) in advance of it.
- b* Beginning point 1 meter from either the right curb, the left curb (if there is a raised median), or the centerline, at a point not less than 50 meters from the yield line.
- c* ●●●●●●●● Vehicle entry path curvature

Figure 5.7: Determination of Path Curvature (*Ourston 1995*)

### 5.4.3 French Recommendation for Deflection<sup>2</sup>

The overall geometric design should not allow the most “stretched out” trajectories to be taken at speeds in excess of 50 km/h (30 mph). A trajectory’s deflection is the radius of the arc that passes at a 1.5m distance away from the edge of the central island and at 2 m from the edges of the entry and exit lanes. The radius of such an arc should be less than 100 m.

If this radius turns out to be too great on a particular project, it should be reduced by modifying the radius of the central island, or, depending on the layout of the various legs, those of the entry or exit lanes. But one should avoid creating too abrupt an inflection at the exit lanes. The position of the intersecting legs around the ring road and the shape of the splitter islands can also be improved to create sufficient deflection.

## 5.5 CENTRAL ISLAND

A central island consists of a raised, often landscaped, non-traversable area and, if applicable, a truck apron. The size of the central island is determined principally by the space available and the need to obtain sufficient deflection to control through vehicle speed while providing adequate radii for required turning movements. The size is influenced by:

- The need to obtain sufficient deflection to control through vehicle speed. Where speeds can be reduced by other means (e.g. approach alignment), there is no limit for size of the island.
- The ability of drivers to recognize the presence of a roundabout.
- The need to provide sufficient time for drivers entering the roundabout to determine whether vehicles on the roundabout are turning right or passing the entry point.

The shape of larger islands can be non-circular to suit a particular site, with the long side of the island oriented for the major flow. However, islands less than the nominal 5 m (16 ft) radius should be circular. Larger central islands are also necessary for roundabouts in high-speed areas and at intersections with more than four legs. Larger central islands improve drivers’ recognition of the form of intersection treatment. In areas where drivers are likely to be unfamiliar with roundabout operation, Austroad recommends the central island diameter be at least 5 m (16 ft) and preferably greater than 10 m (33 ft).

In the Florida guidelines, the central island for the state highway system should have a minimum radius of 7.5 m (25 ft) to the inside edge of the circulating roadway. For local roads, the use of a smaller design vehicle reduces the minimum radius. Single lane roundabouts designed for high-speed rural areas where two-way roads intersect would typically have central islands with radii in the range of 10 to 15 m (33 to 49 ft). Roundabouts on divided roads are generally larger than those on undivided roads.

Additional width required to accommodate the turning paths of larger vehicles, semi-trailers, and buses can be provided by designing the outer portion (truck apron) of the central island for encroachment. This is done by placing mountable curbs along the central island radius for deflection of through vehicles. The encroachment area, between this curb and the raised portion

---

<sup>2</sup> This section is based on a translation of the French guidelines by Michael Ronkin, ODOT.

of the central island, must be designed as load bearing pavement. It should be raised between 50 and 75 mm (2 and 3 in).

## 5.6 CIRCULATING WIDTH

Circulating width depends on the swept paths, and the layout and width of exits and entries. Generally, consistent width throughout the roadway is preferable. The three state guidelines recommend that the width should be 1 to 1.2 times the maximum entry width. California recommends that the width should not exceed 15 m (49 ft).

Short lengths of reverse curve between entry and exits should be avoided. It is difficult to achieve this on three-legged roundabouts or roundabouts with skewed entries. Austroad gives a table for the required width of one, two, or three vehicles in any group turning simultaneously. These widths assume there is only one articulated vehicle in any group turning simultaneously (see Table 5.6 and Figure 5.8).

**Table 5.6: Widths Required for Vehicles to Turn One, Two or Three Abreast** (*Austroad 1993*)

Turning Radius R (m)	One Articulated Vehicle (m)	One Articulated Vehicle plus One Passenger Car (m)	One Articulated Vehicle plus Two Passenger Cars (m)
5	7.6		
8	7.1		
10	6.7		
12	6.5	10.3	
14	6.2	10.1	
16	6.0	9.9	
18	5.9	9.7	
20	5.7	9.6	13.5
22	5.6	9.5	13.4
24	5.5	9.4	13.3
26	5.4	9.3	13.2
28	5.4	9.2	13.0
30	5.3	9.1	12.9
50	5.0	8.8	12.6
100	4.6	8.4	12.2

Note: To convert from meters to feet, multiply by 3.3.

## 5.7 INSCRIBED CIRCLE DIAMETER (ICD)

The decision about the size of a roundabout is a compromise between making it small enough to provide adequate deflection and making it large enough to provide for the appropriate design vehicles. Therefore, the Inscribed Circle Diameter (ICD) depends on the type of vehicle and deflection required for safe speed.

In the Florida guidelines, the minimum ICD for a single lane roundabout on the state highway system should be 30 m (100 ft), based on a WB-15 design vehicle. The layout of a roundabout should be verified by a turning template or software program. Maryland has determined that the smallest ICD for a single lane roundabout is 100 ft on a state highway based on a WB-50 design vehicle. California gives a varied range of ICD from 29 m (95 ft) to 91.4 m (300 ft) for three types of design vehicles. Design values are given in Table 5.7.

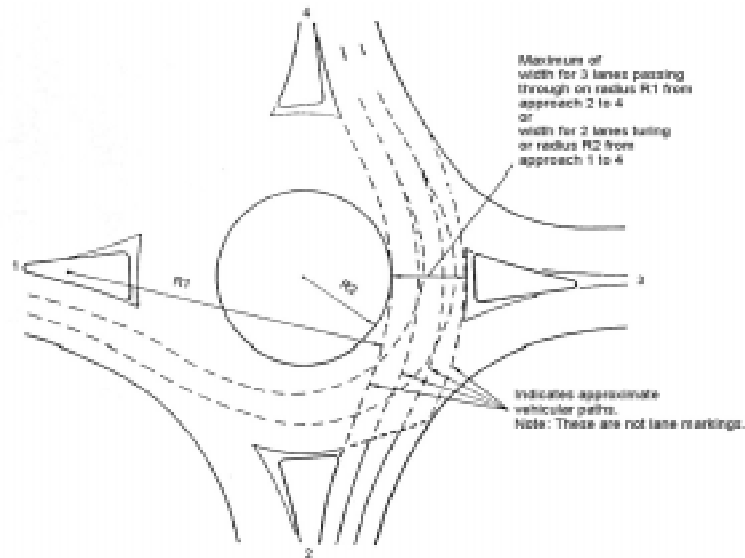

Figure 5.8: Circulating Roadwidths for Roundabouts (*Adapted from: Austroads 1993*)

## 5.8 ENTRY DESIGN

According to the UK, entry width is one of the most significant factors in the capacity of a roundabout. The entry width should be designed to accommodate the design vehicle while ensuring adequate deflection. Figure 5.9 shows the typical roundabout entrance, exit, and splitter island geometric configuration.

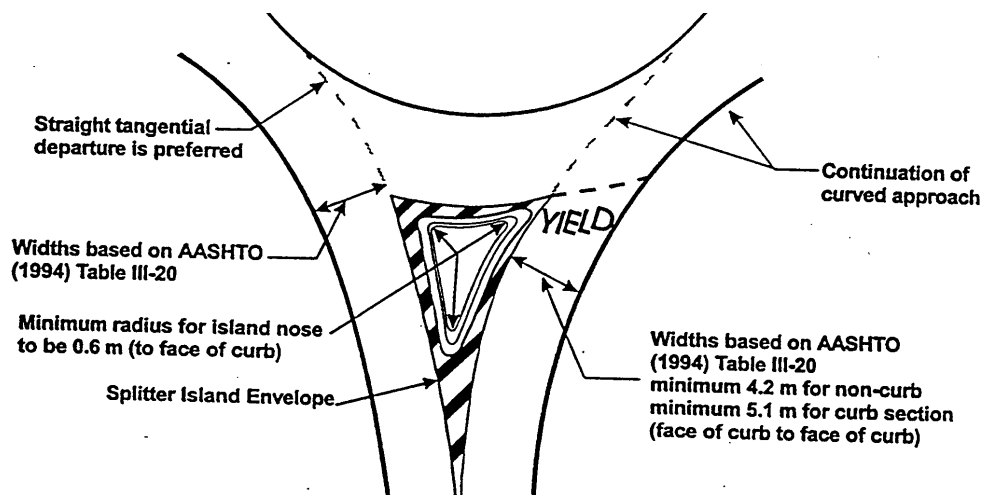
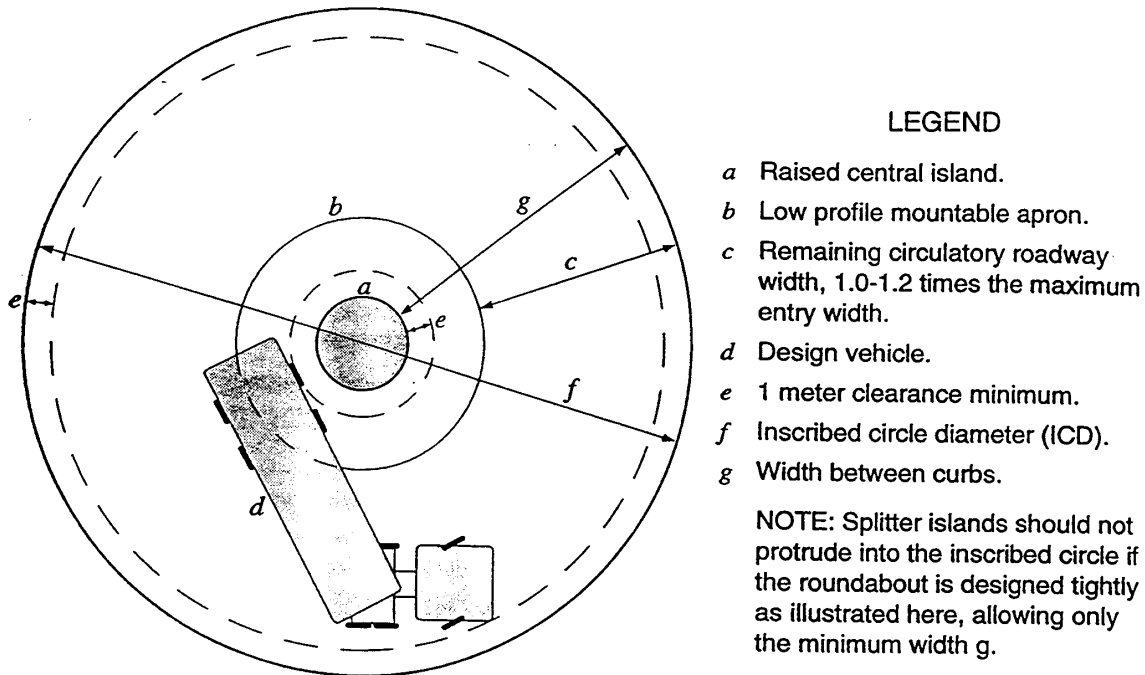

Figure 5.9: Typical Roundabout Entrance, Exit, and Splitter Island Geometric Configuration (*Florida*)

Florida guidelines specify that values for the entry width should be based on AASHTO Table III-20 (Table 5.8). However, as a minimum, the width for a single lane entrance on a state facility should be 4.2 m (14 ft). When a curb is present on both sides of the entering lane, and the splitter island is longer than 10 m (33 ft), the minimum width should be 5.1 m (17 ft) from face of curb to face of curb, based on criteria for passing a stalled vehicle.

Where there is an approach curve leading to the entry curve, it should have the same or a slightly larger radius than the radius of the curved path that a vehicle would be expected to travel through. The approach curve speed should be no more than 15 km/h (10 mph) faster than the maximum negotiation speed through the roundabout.

**Table 5.7: Turning Widths Required for Normal Roundabouts** (Ourston 1995)



Turning Widths Required for Normal Roundabouts							
Meters				Feet			
Inscribed Circle Diameter f	Design Vehicle			Inscribed Circle Diameter f	Design Vehicle		
	STAA Min. g	Calif. Min. g	Bus Min. g		STAA Min. g	Calif. Min. g	Bus Min. g
91.4	6.7	6.6	5.2	300	22.0	21.5	17.0
85.3	6.9	6.6	5.2	280	22.5	21.5	17.0
79.2	7.2	6.9	5.2	260	23.5	22.5	17.0
73.2	7.5	7.0	5.3	240	24.5	23.0	17.5
67.1	7.8	7.3	5.3	220	25.5	24.0	17.5
61.0	8.1	7.6	5.5	200	26.5	25.0	18.0
57.9	8.4	7.8	5.5	190	27.5	25.5	18.0
54.9	8.7	8.1	5.6	180	28.5	26.5	18.5
51.8	9.0	8.4	5.8	170	29.5	27.5	19.0
48.8	9.3	8.7	5.8	160	30.5	28.5	19.0
45.7	9.8	9.1	5.9	150	32.0	30.0	19.5
42.7	10.1	9.6	6.1	140	33.0	31.5	20.0
39.6	11.1	10.2	6.2	130	36.5	33.5	20.5
36.6	12.2	11.1	6.4	120	40.0	36.5	21.0
33.5	13.7	12.3	6.7	110	45.0	40.5	22.0
30.5	*	*	7.0	100	*	*	23.0
29.0	*	*	7.2	95	*	*	23.5

\* Design vehicle requires a larger ICD (inscribed circle diameter).

Table 5.8: Derived Pavement Widths for Turning Roadways for Different Design Vehicles (AASHTO 1990)

Radius on Inner Edge of Pavement R (ft)	Case I, One-Lane, One-Way Operation, No Provision for Passing a Stalled Vehicle										
	P	PT	MH/B	SU	WB-40	WB-50	BUS	A-BUS	WB-62	WB-67	WB-114
50	13	18	19	18	23	26	20	23	26	29	37
75	13	17	17	17	19	22	18	19	25	26	33
100	13	16	16	16	18	21	18	18	23	26	31
150	12	16	16	16	17	19	16	17	21	24	25
200	12	15	15	16	16	17	16	16	19	21	23
300	12	14	14	15	16	17	16	16	18	19	20
400	12	14	14	15	16	16	15	16	17	18	19
500	12	14	14	15	15	16	15	15	17	18	19
Tangent	12	14	14	15	15	15	15	15	15	15	15
Case II, One-Lane, One-Way Operation with Provision for Passing a Stalled Vehicle by Another of the Same Type											
50	20	29	30	29	36	44	31	37	45	49	61
75	19	27	28	27	31	36	29	32	42	45	56
100	19	25	25	25	29	34	28	30	38	42	50
150	18	24	24	24	27	29	25	28	34	37	41
200	18	22	22	23	25	27	25	26	31	35	37
300	18	20	20	22	24	25	24	25	28	31	32
400	17	20	20	22	23	24	22	23	22	29	30
500	17	20	20	22	23	24	22	23	25	27	30
Tangent	17	20	20	21	21	21	21	21	21	21	21
Case III, Two-Lane Operation, Either One or Two-Way (Same Type Vehicle in Both Lanes)											
50	26	35	36	35	42	50	37	43	51	55	67
75	25	33	34	33	37	42	35	38	48	51	62
100	25	31	31	31	35	40	34	36	44	48	56
150	24	30	30	30	33	35	31	34	40	43	47
200	24	28	28	29	31	33	31	32	37	41	43
300	24	26	26	28	30	31	30	31	34	37	38
400	23	26	26	28	29	30	28	29	33	35	36
500	23	26	26	28	29	30	28	29	31	33	36
Tangent	23	26	26	27	27	27	27	27	27	27	27

The entry radius will vary depending on the geometric characteristics of the approach and other roundabout elements, but should not be less than 10 m (33 ft) on state facilities and 6 m (20 ft), or 20 m (66 ft) for minimum for passenger cars, on off-system facilities. The left edge of the entry path should be designed to be radial to the central island.

Maryland recommends that the entry width should be between 11 ft (3.5 m) and 15 ft (4.5 m) per entry lane. The entry width should be less than or equal to the circulating width. Approaching drivers should be given a clear indication of the sharpness of the curve they will have to negotiate, since the speed at which drivers will enter the circle is dependent on their perception of the sharpness of the first curve. In the California guidelines, lane widths at the yield line should not be less than 3 m (10 ft). It is good practice to add at least one extra lane width on the

entry approach. Austroad recommends the entry lane width fall between 3.4 and 4.0 m (11 and 13 ft). Exceptions are for curbed single lane entrances where a minimum width of 5.0 m (16 ft) between curbs is usually provided to allow traffic to pass a disabled vehicle.

Increase in entry radius will result in an increase of capacity until the radius reaches 20 m (66 ft). After that, the increase of the radius will result in very little increase in capacity. The minimum entry radius should be 6 m (20 ft); a good practical design is about 20 m (66 ft). When a roundabout is designed for long trucks in particular, the entry radius should not be less than 10 m (33 ft). Large entry radii will almost certainly result in inadequate entry deflection. For example, it will not be possible to achieve the deflection standard if the entry radius is 100 m (328 ft) or more.

Entry angle also affects capacity. As the angle increases, capacity decreases slightly. If possible, the angle should lie between 20 and 60 degrees. The best entry angle is about 30 degrees.

The speed through the approach curve should be no more than 10 km/h (6 mph) and 15 km/h (9 mph) faster than the maximum negotiation speed through the roundabout. On arterial roads with two or more lanes, the radius of the entrance curve should not be so small as to reduce speed to a degree that drivers consider unreasonable or have difficulty in negotiating. This can result in drivers ignoring lane lines and cutting across adjacent lanes, particularly if the curve is short. The desirable minimum radius to a two or three-lane is 30 m (100 ft).

## **5.9 EXIT DESIGN**

While the entry curves are designed to slow vehicles down, the exit should be as easy for vehicles to negotiate as possible. For this reason, the exit radius should generally be greater than the circulating radius. Ideally, a straight path tangential to the central island is preferable for departing vehicles. As with other elements of the roundabout, the exit width and alignment should be checked using a turning template or software.

The California guidelines go into some detail about how to design an exit. The spacing between an exit and the preceding entry should not be less than that which results from the combination of a minimum entry radius of 6 m (20 ft) and a minimum exit radius of 20 m (66 ft). Desirable radii of 20 m for the entry and 40 m (131 ft) for the exit should be used where possible.

A right curb radius of about 40 m at the mouth of the exit is desirable, but for larger rural roundabouts this may be increased to suit the overall intersection geometry. In any case, this radius should not be less than 20 m or more than 100 m (328 ft).

Wherever possible, the width of the beginning of an exit, measured radially to the exit curve, should allow for an extra traffic lane over and above that of the link road downstream. For example, if the downstream road link is one lane, the width at the exit should be 7.0 to 7.5 m (23 to 25 ft); and if the road link is two lanes, the width should be 10 to 11 m (33 to 36 ft). This extra width should be reduced on the right in such a way as to keep exiting vehicles from encroaching onto the entering roadway at the end of the splitter island. Normally, this would be at a taper of 1:15 to 1:20, although where the exit is on an uphill gradient, the local widening

may be extended to reduce intermittent congestion from slow moving heavy vehicles and to provide a passing opportunity for faster vehicles. Similarly, if the exit road is on a right hand curve, it may be necessary to extend the taper length and the length of the splitter island. Within an exit to an undivided road, a minimum width of 6 m (20 ft) between curbs should be provided adjacent to splitter islands to allow traffic to pass a disabled car. Figure 5.10 shows the typical exit to an undivided road.

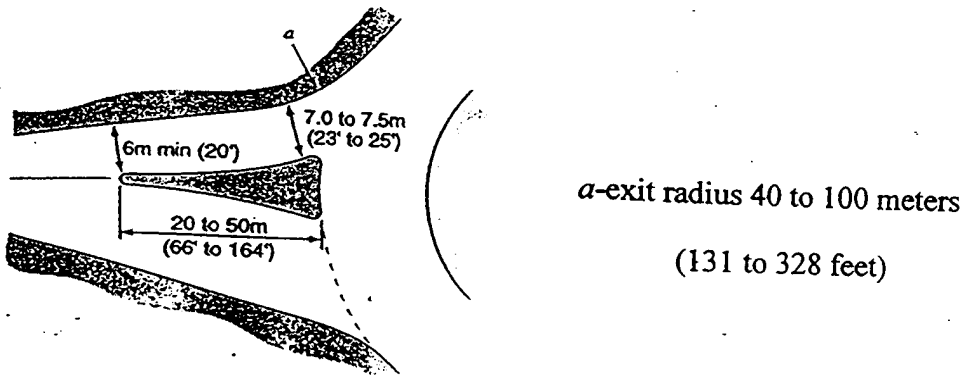

5.10: Typical Exit to an Undivided Road (Ourston 1995)

Figure

## 5.10 SPLITTER ISLAND

The purposes of splitter islands are (Bared, Prosser and TanEsse 1997):

- To help see the upcoming roundabout, to reduce entry speed, and provide space for a comfortable deceleration distance;
- To physically separate entering and exiting traffic (possibly improving capacity) and avoid wrong-way movement;
- To control entry and exit deflection;
- To provide a refuge for pedestrians, and a place to mount traffic signs.

Splitter island length may vary with approach speed. It does not have to be equal to the comfortable deceleration distance unless the approach speed is very high and visibility is below the stopping sight distance. Generally, the sizes are adapted to the central island and inscribed circle dimension. Splitter islands should be provided on all roundabouts installed on arterial and collector roads in rural and urban areas.

Austroroad and Maryland recommend splitter islands on arterial road roundabouts be of sufficient size to shelter a pedestrian (Austroroad: 2.4 m (7.9 ft) wide) and be a reasonable target to be seen by approaching traffic. Austroroad also recommends a minimum area of 8 to 10 m<sup>2</sup> (86 to 108 ft<sup>2</sup>) be provided on any arterial road approach. The length of curve on the entry side of the splitter island should be at least 60 m (200 ft).

Florida gives a minimum splitter island dimension of 2.4 m (7.9 ft) at the edge of the inscribed circle on the state highway system, with a minimum width at the entry approach of 1.2 m (3.9 ft). This results in a minimum nose radius of 0.6 m (2 ft) (to the face of curb). The minimum length for the island should be one car length (6 m), thus creating an island of at least 10 m<sup>2</sup> (108 ft<sup>2</sup>).



When the splitter island is designed to provide refuge for pedestrians, Florida recommends the minimum width be 1.8 m (6 ft) at the point of crossing (usually one car length back from the yield line), and the minimum length of the splitter island should be increased to 10 m (33 ft). This width accommodates a wheelchair with attendant and is also adequate for use by a cyclist.

In high speed areas, the splitter island should be relatively long (ideally at least 60 m or 200 ft for Maryland) to give early warning to drivers that they are approaching an intersection and must slow down. The splitter island and its approach pavement markings should extend back to encourage drivers to start slowing down. The lateral restriction and funneling provided by the splitter island will aid in speed reduction as vehicles approach the roundabout. Curbs should be placed on the right-hand side for at least half of the length of the splitter island to strengthen the funneling effect.

## 5.11 GRADES AND SUPERELEVATION

Normal curve superelevation through the roundabout is generally not necessary as speeds are constrained and drivers tolerate higher values of the coefficient of sideways friction when traveling through an intersection.

As emphasized in previous sections, the layout of the roundabout must be clearly visible to approaching drivers. Sloping the circulating roadway away from the central island is one way of helping to achieve the desired visibility. Designing the roundabout for maximum visibility in this way does, however, mean accepting negative superelevation for left turning and through vehicles in the circulating lanes. The recommended cross slope in each guideline is as follows:

Florida:	0.02 and minimum 0.015 outward
California:	0.02 and maximum 0.025 outward
Maryland and Austroad:	0.025 to 0.03 m/m and minimum 0.02 outward

Exceptions for this practice include:

- 1) Generally sloping topography, where the cross slope should approximately match the slope across the whole of the roundabout. The cross slope at these roundabouts can vary around the circulating lanes but it should remain within the range of  $\pm 0.02$ . Care must be taken to accommodate large trucks at crown or breakover points and in blending grades at entries and exits. Locating a roundabout on grades greater than two percent should be avoided.
- 2) Large roundabouts where vehicles will travel on the circulating road for some distance. In these situations, a crown along the centerline of the circulating roadway may be satisfactory. The roadway could also be positively superelevated by sloping toward the central island. This would improve driver comfort but would encourage an increase in vehicle speed within the roundabout and reduce the visibility of the circulating roadway and the central island.

According to French guideline, installing a roundabout on a roadway with a grade lower than 3% is generally not a problem. On roadways with a grade greater than 6%, a roundabout is generally considered unsuitable. However, under the same conditions, other types of intersections (at-grade, or signal controlled) usually don't perform any better, and can create even greater safety

concerns. So one shouldn't exclude consideration of a roundabout on grades over 6% when retrofitting existing roads. On a new roadway, eliminating the roundabout solution shouldn't lead to providing an alternative intersection type, but should encourage designers to eliminate the intersection or move it elsewhere.

At grades between 3% and 6%, certain conditions can be considered unsafe. Also, areas of reverse superelevation on the circulating roadway, or areas of normal superelevation on the entrance and exit ramps, shouldn't have lateral slopes greater than 3%. On roundabouts located on a sloped plane, no slope should be added to the normal slope of the circulating roadway (1 to 2%). Placing a roundabout at the crest of a vertical curve of one of the intersecting roadways should be avoided, but if this must be done, then the diameter should not be too small. But if a roundabout is located on a slope, or at the low point of a vertical curve, a smaller roundabout design makes it possible to reduce the slope of the circulation roadway by about 1 to 2%.

## **5.12 PAVEMENT MARKING**

### **5.12.1 Yield Line**

A yield line is required at the entry point of each approach to a roundabout. There should be no painted line across the exit from a roundabout.

### **5.12.2 Splitter Islands and Approaches**

The splitter islands should have clear yellow markings at the approach of both roundabout entry and exit. Typical pavement markings are given in Figure 5.11. Raised reflective pavement markings as well as thermoplastic markings can be used to increase visibility. Pavement markings alone are not an effective means of directing vehicle paths through a roundabout. They should not be used as a substitute for a raised splitter island or outside curbs.

### **5.12.3 Pavement Marking in the Circulating Roadway**

While there is no conclusive evidence as to whether there should be lane lines delineating the circulating lanes within the roundabout, it is felt that such pavement marking may confuse rather than help drivers in the performance of their task of negotiating the roundabout. With multi-lane roundabouts, pavement markings may also mislead drivers into thinking that vehicles must exit exclusively from the outer lane of the roundabout.

Decisions about the use (or lack of use) of pavement markings should be made on a case by case basis. Joe G. Bared, et al (*Bared, Prosser and TanEsse 1997*) suggest that lane markings are unnecessary, particularly for a width less than 9 m (30 ft) or less than three-lane entries.

## **5.13 SIGNING**

The general basis for roundabout signing is similar to that for signing any other geometric features along a highway. Proper advance warning, directional guidance, and regulatory control are required to avoid any false sense of driver expectancy. Typical signing for a roundabout is shown in Figures 5.11 and 5.12.

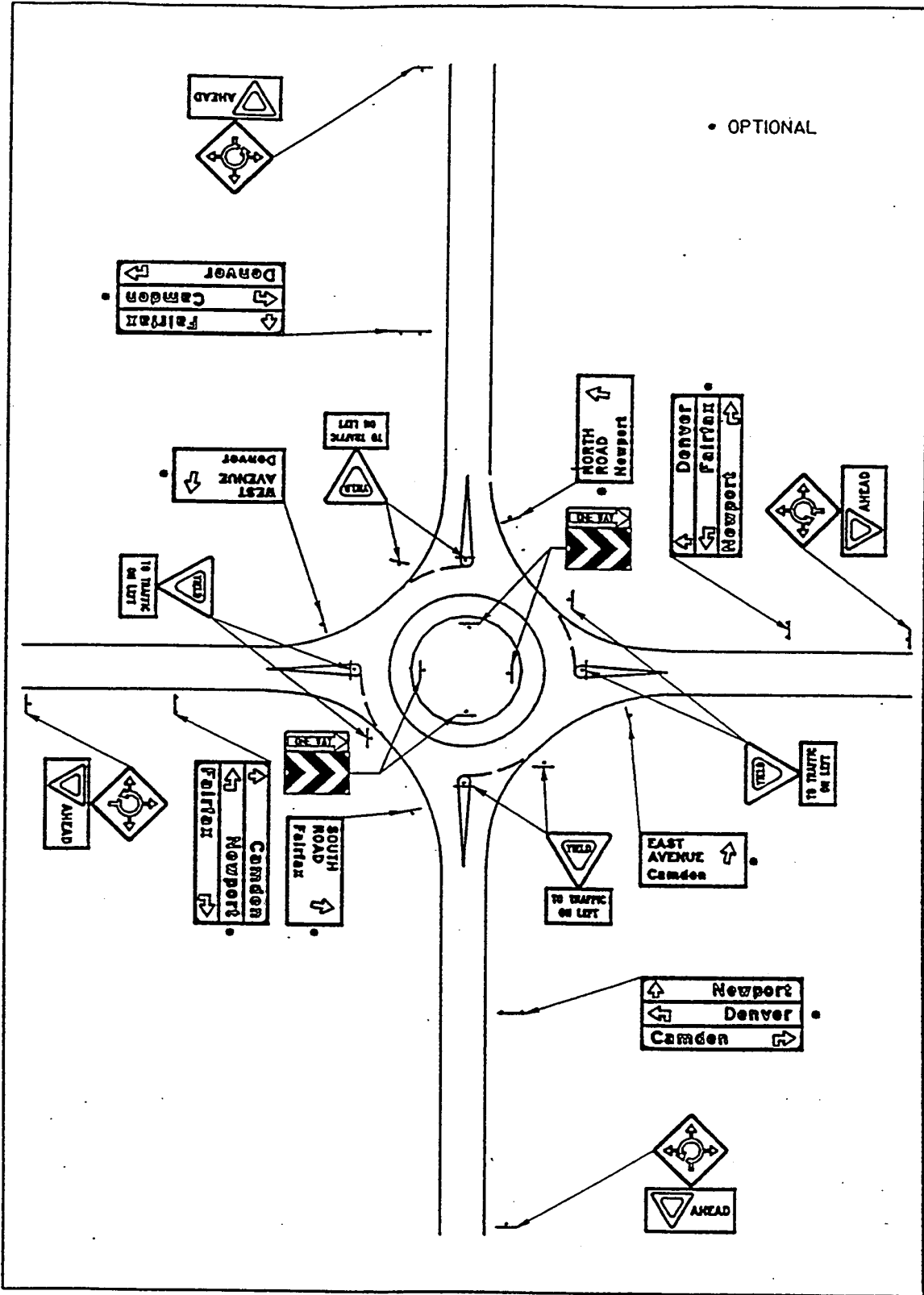

Figure 5.11: Typical Signing for a State Route Roundabout (Maryland 1995)

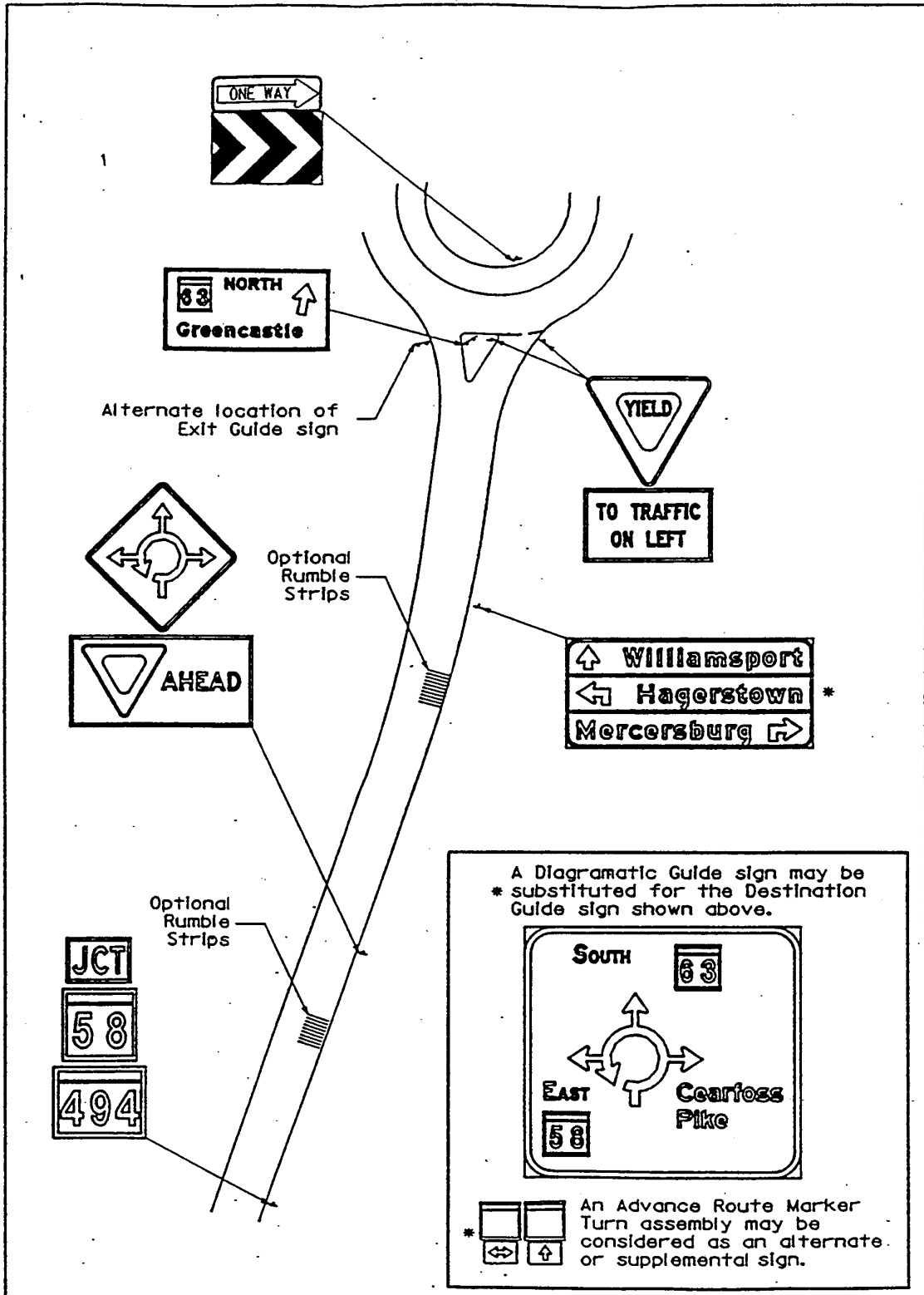

Figure 5.12: Typical Signing for a Local Road Roundabout (Maryland 1995)

## 5.14 LIGHTING

Since the geometric design of a roundabout differs from other types of traffic control, particularly the construction of a central island in the middle of an intersection, it is important for drivers to recognize this type of traffic control as they approach the roundabout.

The geometric features that are required for proper deflection must be clearly identified by the drivers. Appropriate lighting is therefore required at all roundabouts. Because of the possible variability of roundabout geometry at each intersection or project, specific guidelines on lighting are not appropriate. However, Florida, Maryland, and Australia recommend some basic considerations as follows:

- Good illumination should be provided on the approach nose of the splitter islands, at all conflict areas where traffic is entering the circulating stream and at all places where the traffic streams separate to exit the roundabout.
- Special consideration should be given to the lighting of any pedestrian crossing area.
- Consideration must be given to the placement of lighting in regards to areas at risk for a run-off-the-road type accident. The columns and other poles should not be placed on the small splitter islands, on the central island directly across from an entry roadway, or on the right-hand perimeter just downstream of an entry point.

The minimum light level set by the Florida Department of Transportation for roundabouts is 16 lux. Austroad suggests the lighting requirements at local roundabouts as follows:

**Table 5.9: Lighting** (*Austroad 1993*)

Road types	Requirements
Minor Local Road/Local Road Intersections (On intersecting roads less than 7.5 m (25 ft) wide)	One high pressure 250 W sodium light
Major Local Road/Local Road Intersection	One high pressure 250 W sodium light on two major approaches
Roads of Higher Traffic Volume or where there are operational problems	One high pressure 250 W sodium light on all approaches

California recommends lighting columns be arranged around the perimeter of the roundabout in a simple ring, with the lights equidistant from the center and from each other. Lighting should extend at least 60 m (197 ft) back along each exit road. Mounting height should be uniform throughout the intersection and not less than on any approach road. Minimum horizontal illuminance at the curblines should be as given in Table 5.10. The minimum illuminance required should be not less than the highest level of lighting for any of the approach roads. The minimum horizontal illuminance for a mini-roundabout without a curbed central island should be 20 lux.

**Table 5.10: Minimum Horizontal Illuminance at the Curblines** (*Ourston 1995*)

Total Entering Peak Hour Volume	Minimum Horizontal Illuminance (Lux)
PHV > 5000	20
1000 < PHV < 5000	15
PHV ≥ 1000	10

## 5.15 LANDSCAPING

Roundabouts can offer advantages over other forms of channelization with respect to landscaping. A good landscape design will enhance the aesthetics of the area while providing safety. The general rules for landscape design at roundabouts:

- Either enhance or not interfere with the visibility of the layout of the roundabout,
- Do not introduce hazards to the roundabout,
- Maintain minimum stopping and turning sight distances,
- Maintain minimum horizontal clearance and clear zone requirements,
- Do not obscure the view of signs and other vehicles in the roundabout,
- Clearly indicate to the driver that they cannot pass straight through the roundabout,
- Improve the aesthetics of the area while complementing the surrounding streetscape as much as possible,
- Discourage pedestrian traffic through the central island.

Figure 5.13 is an example of landscape design of a central island from the Maryland guideline. Maryland also recommends, when planting in an old roadbed, that it is necessary to excavate the old roadbed out (to a depth two feet below the original road surface) and backfill with approved topsoil to provide for adequate growing conditions.

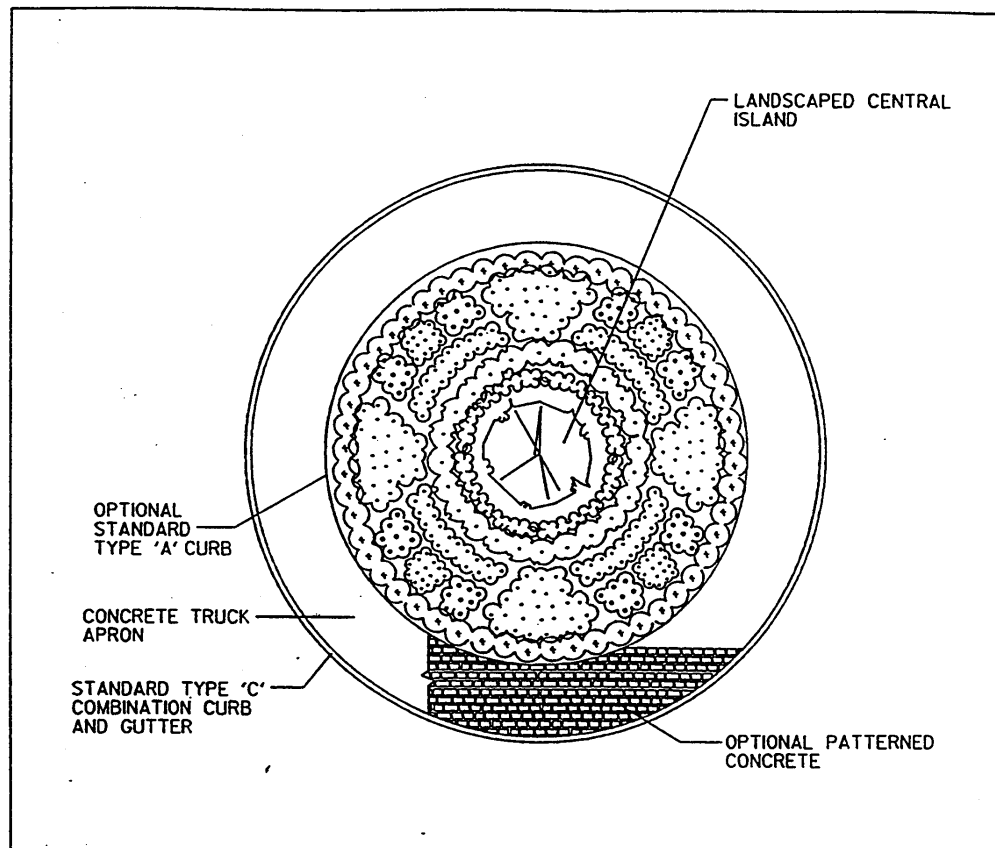

Figure 5.13: Plan of Landscaped Central Island (*Maryland 1995*)



#### **5.17.1.2      *Design Speed***

For small roundabouts, the negotiated speed through the roundabout should be restricted to less than 40 km/h (25 mph). When pedestrian volumes are high, the speed should be even lower. The reverse curve at the approach leg is recommended in high speed environments to control speeds of vehicles entering roundabouts. Speed differential between entry/circulating and circulating/exit should be minimized.

#### **5.17.1.3      *Approach Characteristics***

In general, roundabouts should not have more than four legs. More access points will increase drivers' confusion. A 90-degree angle between each leg is the most preferable treatment. This will help guide drivers traveling through roundabouts with less confusion finding the exit legs.

#### **5.17.1.4      *Entry and Exit Width***

Entry and exit widths will vary depending on the geometry of roundabouts and the design vehicles. Entry and exit lane widths directly affect the location of the vehicle paths through roundabouts. For single lane roundabouts, entry, exit, and circulating lanes should provide sufficient space to accommodate vehicles passing a stalled vehicle. Smaller entry and exit widths are recommended in order to decrease speed through roundabouts, thus reducing accidents. However, these smaller widths will result in longer delays and capacity reduction.

#### **5.17.1.5      *Circulating Width***

Wide circulating lanes may encourage drivers to travel at higher speeds and cause slipping on wet pavement; this creates a risk for bicyclists and should be avoided. It is recommended that the width should be 1.0 to 1.2 times the maximum entry width and should accommodate truck movement safely.

#### **5.17.1.6      *Entry and Exit Curve***

Entry and exit curves should provide for smooth maneuvering through roundabouts while providing sufficient deflection. A sharp curve should not be used because it gives minimum separation between two adjacent legs. Single radii between two adjacent legs encourage drivers to increase their speeds, thus a three-centered curve is recommended. For pedestrian safety, exit curves should be designed so as drivers will not abruptly increase their speed while leaving.

#### **5.17.1.7      *Sight Distance***

Visibility is an important concern in the design of roundabouts. While the AASHTO geometric design standard is not available for roundabouts, the recommendations of the Maryland and Florida guidelines are recommended.



#### **5.17.1.8      *Deflection***

Deflection at roundabouts is required to slow down all drivers. The operational speed through a roundabout should be kept within the safe speed (40 km/h (25 mph)). The maximum radius of curvature from the center of the central island to a vehicle path should be at least 75 m (250 ft) ( $V=40$  km/h,  $e=0$ ,  $f=0.17$ ). The distance between the edge of the central island and vehicle path should be 1.5 to 2.0 m (5 to 6.5 ft).

#### **5.17.1.9      *Central Island***

The size of the central island should be determined principally by the space available and the need to obtain sufficient deflection. In areas where drivers are likely to be unfamiliar with roundabout operation, a larger central island is recommended.

#### **5.17.1.10     *Splitter Island***

Splitter islands are used to provide pedestrian refuge and direct approaching vehicles. The size of a splitter island should be sufficient for both pedestrians and those using wheelchairs. In areas where pedestrian volumes are high and vehicle speeds are low (less than 30 km/h (20 mph)), it is preferable to build a cut-through path in the raised island. Splitter island length varies with approach speed.

#### **5.17.1.11     *Superelevation***

Superelevation is not necessary due to low speed operations at roundabout. The drainage slope should be outward to discourage speeding vehicles



## **6.0 CAPACITY AND DELAY AT ROUNDABOUTS**

Significant study has been done to develop methodologies to evaluate the functional performance of roundabouts. Capacity and delay are indicators used by most countries to assess roundabout performance.

This chapter reviews formulas that may be suitable to adopt for use in Oregon. Capacity formulas are presented first, with delay formulas in the second part. The US studies of the proposed capacity measures are also identified in the last section of the chapter.

### **6.1 THE REVIEW OF CAPACITY FORMULAS**

Roundabouts have been accepted around the world since the introduction of the off-side priority rule. Prior to the rule, conventional roundabouts performed as a weaving section between two streams: circulating and entering flows. With the new rule, entering traffic now has to give way to circulating traffic and enter when accepted gaps are available. The operational basis is measured by the number of vehicles entering the roundabout. Capacity is measured in terms of the entry capacity, rather than of weaving section capacity.

Because drivers enter the roundabout only when the gap in the circulating traffic is large enough, the capacity of the roundabout will depend primarily on the circulating flow and the availability of gaps. Consequently, the entry capacity decreases if the circulating flow increases, since there are fewer gaps for entering drivers. The dependence of entry capacity on circulating flow is known as the entry/circulating flow relationship, and depends on the drivers' interaction and roundabout geometry.

Fundamentally, two methodologies can be used to assess the entry/circulating flow relationship. The first is a regression analysis and the second is the gap acceptance theory. Most countries have adopted their capacity formula based on either one of these two methodologies. For this report, the regression base is presented by the UK and Germany formula, while the gap acceptance theory is presented by the Australian and Germany formula.

The UK capacity formula, described in section 6.1.1.1, is the summarized work conducted by R.M. Kimber in 1980. Kimber's formula is accepted in the UK and is now being used to evaluate some roundabouts in the US, using the RODEL and ARCADY programs (described in chapter 7). Germany's formula, in section 6.1.1.2, is based mostly on the articles by Werner Brilon, et al. in recent years.

Section 6.2.2.1 describes the development of the Australian capacity formula from Tanner's formula to Troutbeck's formula in the Austroad Design Guideline 1993. Most of the presented information is summarized from the articles by R.J. Troutbeck. The proposed gap acceptance formula for Germany developed by Ning Wu is presented in section 6.2.2.2. The formula has been corrected from the original article by Brilon with the confirmation of the author.

## 6.1.1 Regression Capacity Formula

### 6.1.1.1 The UK Capacity Formula

The UK roundabout capacity formula is based on Kimber's study in 1980. The first approach is a linear approximation used to determine the entry capacity of a roundabout. Kimber's capacity formula is:

$$Q_e = F - f_c Q_c \quad (6.1)$$

where  $Q_e$  = Entering Capacity (vph)  
 $Q_c$  = Circulating Flow (vph)  
 $F, f_c$  = Parameters defined by roundabout geometry

Kimber's equation could be used for both large and small roundabouts. Kimber used data from Philbrick (1977), Kimber and Semmens (1977), Glen et al. (1978), and Ashworth and Laurence (1977 and 1978) to acquire 185 hours of data. Kimber used a number of parameters to describe the entry geometry, as defined below (see Figure 6.1 for detail):

$e$  = the entry width (m)  
 $u$  = the circulation width (m)  
 $D$  = the inscribed diameter (m)  
 $l, l'$  = the effective length, where the flare is developed (m). Two methods could be used to identify flare, 1) the perpendicular straight line to  $\frac{1}{2}(e-v)$ , or 2) the parallel curved line at the same point. The latter gave the longer length as 1.6 times of the first one.  
 $v$  = the approach road half width (m)  
 $r$  = the entry radius (m)  
 $\phi$  = the angle of entry (degree)  
 $S$  = the sharpness of the flare where  $S = (e-v)/l$  or  $S = 1.6(e-v)/l'$   
 $W$  = the width of the weaving section (m)  
 $L$  = the length of the weaving section

The ranges of the geometric parameters in the tested database were

$e$  : 3.6-16.5 m  
 $v$  : 1.9-12.5 m  
 $l'$  : 1- $\infty$  m  
 $S$  : 0-2.9  
 $D$  : 13.5-171.6 m  
 $\phi$  : 0-77°  
 $r$  : 3.4- $\infty$  m

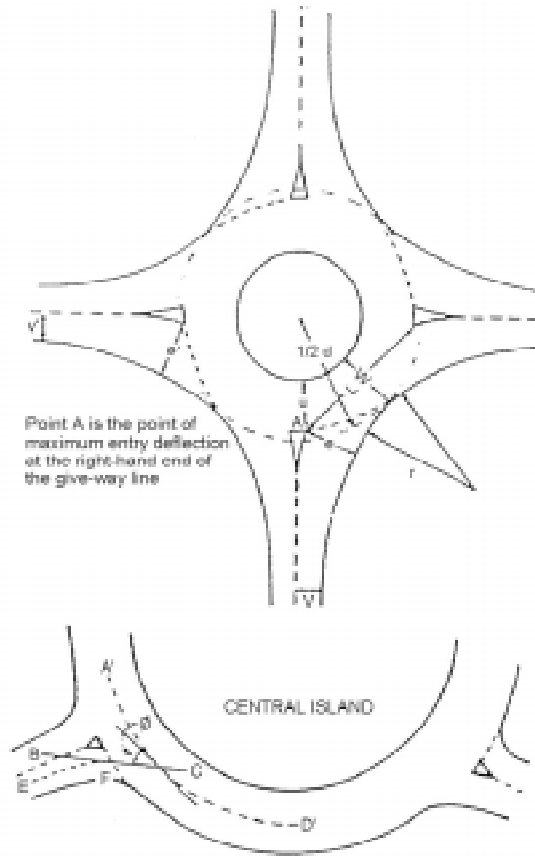

Figure 6.1: Definition of Geometric Parameters (*Semmens 1985*)

Kimber continued to use a passenger car unit (pcu) of heavy vehicles of 2 in the analysis, as did Glen et al (1978).

Kimber regressed the number of entry lanes,  $n$ , with the effective entry width,  $x_2$ , given by the equation:

$$x_2 = v + \frac{e - v}{1 + 2S} \quad (6.2)$$

He then sought equations for the slope and intercept of the entry/circulation flow formula by linear regression of  $F$  and as a function of  $x_2$ . Although the inscribed diameter largely distinguished the larger conventional roundabouts from the smaller off-side priority ones, the entry capacity was greater on larger roundabouts with the same entry flow and geometry. Hence, the magnitude of the slope,  $f_c$ , decreased as the diameter increased and accordingly, a factor,  $t_d$ , was included in the equation for  $f_c$  to account for this effect. Kimber obtained the equation

$$f_c = 0.210 (1 + 0.2 x_2) t_d \quad (6.3)$$

for the slope, and the equation

$$F = 303x_2 \quad (6.4)$$

for the intercept, where

$$t_d = 1 + 0.500 / [1 + e^{\frac{D-60}{10}}] \quad (6.5)$$

Values of  $t_d$  were equal to 1.0 for large diameters and to 1.5 for very small diameters. For all but the largest roundabouts ( $d > 30$  m)  $t_d$  can be set to 1.48.

Kimber also found that the angle of entry,  $\phi$ , and the radius,  $r$ , have a slight effect on the capacity. As their effect was small Kimber decided to modify the equation 6.1 by including a correction factor to equation 6.1 such that

$$Q_e = k(F - f_c Q_c) \quad (6.6)$$

where  $k = 1.151 - 0.00347\phi - 0.978/r$

For Kimber's typical sites,  $\phi$  was about  $30^\circ$ ,  $r$  was about 20 m and under these conditions  $k$  was equal to 1. Values of  $k$  can be generally expected to be within 0.9 to 1.1.

Kimber tested for linearity, concluding that a parabolic function did not significantly improve the predictive ability. He decided to accept the linear approximation. The resulting standard error of prediction for a typical site (for which  $Q_e = 1300$  pcu/h or so) is about 200 pcu/h or about 15 percent of the entry capacity.

### 6.1.1.2 Germany's Formula

Germany uses an approach similar to that of the UK. Germany investigated both regression and gap theory and decided to utilize the UK regression analysis. However, in contrast with the UK linear approximation, an exponential regression line was used to describe the entry/circulating flow relationship because of the better agreement with the gap acceptance capacity formula developed by Siegloch in 1973.

Germany's formula:

$$Q_e = A * e^{-BQ_c / 10000} \quad (6.7)$$

where  $Q_e$  = entering capacity (vph)  
 $Q_c$  = circulating flow (vph)  
 A, B = defined parameters

Several types of roundabouts were investigated. The parameters A and B in this equation have been determined separately from the measurements by regression calculation for different number of entries. The values of A and B are shown in Table 6.1, and the regression curve is shown in Figure 6.2.

**Table 6.1: Formula for Calculating Roundabout Capacity (Brilon 1990)**

Number of Lanes		A	B
Entry	Circulating Roadway		
1	1	1089	7.42
2-3	1	1200	7.30
2	2	1553	6.69
3	2	2018	6.68

The German results are between 0.7 and 0.8 of the English values. In Birgit Stuwe's opinion (Stuwe 1991), this difference can be explained by different driver behavior. It is assumed that drivers in England are more familiar with roundabouts because this type of intersection control has been in place in England for a long time. In Germany, however, at the time of this study, roundabouts are still an exotic solution.

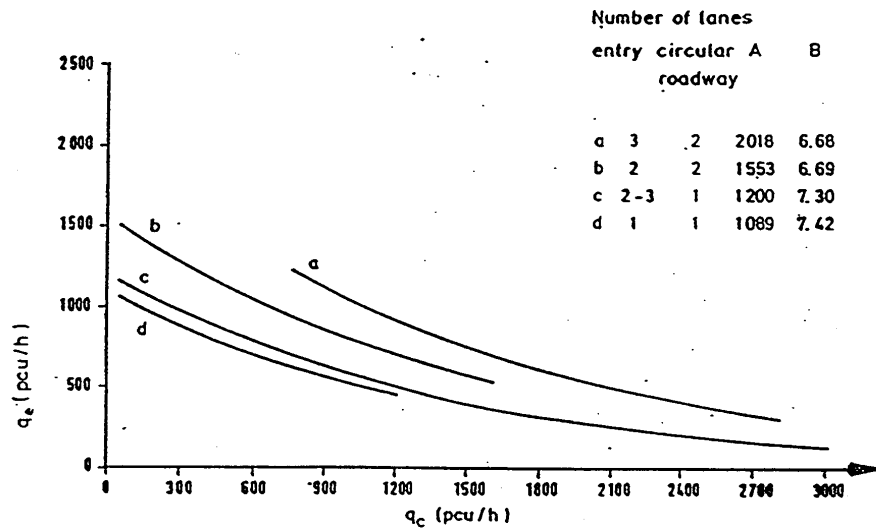

Figure 6.2: Parameters for Exponential Analysis (Brilon 1990)

Recently, continuing research from the federal government in Germany shows that the linear function instead of an exponential function has a better agreement of the variance of data (Brilon, Wu and Bondzio 1997). The new capacity formula is:

$$Q_e = C + DQ_c \quad (6.8)$$

where C and D are as shown in Table 6.2.

**Table 6.2: Parameters for Linear Regression (Brilon 1997)**

No. of Lanes Entry/Circle	C	D	N (Sample Size)*
1/1	1218	-0.74	1504
½ or 1/3	1250	-0.53	879
2/2	1380	-0.50	4574
2/3	1409	-0.42	295

\*no. of observed 1-minute intervals

At the same time, Ning Wu has modified the basic idea of gap acceptance in order to estimate the roundabout capacity. Wu's capacity formula will be discussed in the next section.

## 6.1.2 Gap Acceptance Theory and Roundabout Capacity

The empirical formulation has some drawbacks, e.g., data have to be collected at oversaturated flow (or at capacity) level. It is a painstaking task to collect the significant amount of data to ensure reliability of results, and this method is sometimes inflexible under unfamiliar circumstances, e.g., when the value is far away out of the range of regressed data. Consequently, researchers searched for other reliable methods for determining roundabout capacity. Many researchers agree that a gap acceptance theory is a more appropriate tool. An advantage of this method is that the gap acceptance technique offers a logical basis for the evaluation of capacity. Secondly, it is easy to appreciate the meaning of the parameters used and to make adjustments for unusual conditions. Moreover, gap acceptance conceptually relates traffic interactions at roundabouts with the availability of gap in the traffic streams.

The development of gap acceptance capacity formula was fundamentally based on Tanner's capacity equation for priority intersection. The equation has been adjusted in order to relate the equation with data observed in the field. Australia has adapted Tanner's equation with modifications for application in Australia.

### 6.1.2.1 Australian Capacity Formula

Tanner (1962) analyzed the delays at an intersection of two streams in which the major stream had priority. He assumed that both major and minor stream arrival are random, but that a major stream vehicle can not enter the intersection sooner than  $\Delta$  seconds after the preceding major stream vehicle. The minor stream vehicle then enters when any available gap is greater than  $T$  seconds. If the chosen gap is large enough, several minor streams vehicles then follow each other through the intersection at intervals of  $T_0$  seconds. Tanner's equation would then be

$$q_e = \frac{q_c(1 - \Delta q_c) e^{-q_c(T-\Delta)}}{1 - e^{-q_c T_0}} \quad (6.10)$$

where

$q_e$  = Entering Capacity (veh/sec)

$q_c$  = Circulating flow (veh/sec)

$T$  = Critical gap

$T_0$  = Follow-up time

$\Delta$  = Minimum headway

From Horman and Turnbull's study in Australia, they suggested that the values of  $T = 3-4$  s,  $T_0 = 2$  s, and  $\Delta = 1$  or 2 s were suitable for Australia conditions (Troutbeck 1984). For two-lane circulating flow, the values of  $T = 4$  s,  $T_0 = 2$  s, and  $\Delta = 0$  provided a satisfactory prediction of entry capacity for circulating flows in the 300-2000 pcu/hr range (Avent and Taylor 1979).



Avent and Taylor conducted the study to test these values. They studied three Brisbane roundabouts and found that the proper values should be  $T = 3.5$  s. and  $T_0 = 2.0-2.7$  s. They also questioned Horman and Turnbull's conclusion that the minimum gap  $\Delta$  on multilane circulation flow was zero. Avent and Taylor concluded that  $T$  was equal to 2.5,  $T_0$  was equal to 2.1, and  $\Delta$  was equal to 2.2 for single lane roadways and 1.1 for two lane roadways. Figure 6.3 is the nomograph analysis of Tanner's formula used by National Association of Australian State Road Authorities (NAASRA) by Avent and Taylor.

Tanner's assumptions that  $T$  and  $T_0$  are constant and that headway distribution of priority stream was random were not realistic (*Troutbeck 1988, 1991*). In reality, most vehicles travel within two stages. The first one is a bunched vehicle stage; these vehicles are closely following preceding vehicles. The second one is a free vehicle stage; these vehicles travel without interaction with the vehicle ahead. R.J. Troutbeck modified Tanner's equation with Cowan's M3 distribution.

The modified formula is

$$Q_e = \frac{3600(1-\theta)q_c e^{-\lambda(T-\Delta)}}{1 - e^{-\lambda T_0}} \quad (6.11)$$

where

$Q_e$  = Entering Capacity (veh/h)

$q_c$  = Circulating Flow (veh/sec)

$\theta$  = the proportion of bunched vehicles

$\Delta$  = the minimum headway in the circulating streams, and these are 1 second for multilane and 2 second for single lane

$T$  = the critical gap

$T_0$  = the follow-up time

$\lambda$  = decay parameters =  $\frac{(1-\theta)q_c}{1 - \Delta q_c}$

Troutbeck also questioned real drivers' interactions at roundabouts. His assumption was that both traffic streams would have some influence on each other. To examine this issue, Troutbeck conducted a study in 1990. The conclusions of his study were as follows:

- Drivers exiting at the same leg had little influence on the behavior of entering drivers.
- Different entry lanes had different characteristics depending on the number of vehicles in each movement. Drivers turning right could be expected to use the right hand lane. Similarly, drivers turning left would use the left entry lane.
- Priority sharing occurred in the real world. Circulating vehicles would decelerate and give way to entering vehicles. This appeared to give a shorter mean follow-on time and critical gap for entering vehicles.
- The entering vehicles generally gave way to all circulating vehicles. Entering drivers were often unsure whether a circulating driver to their left intended to leave at the next exit and travel across their paths. Consequently, entering drivers tended to give way to all circulating vehicles, even where the circulating roadway was two or more lanes wide.

CAPACITY FOR MULTI-LANE  
CIRCULATING FLOW ROUNDABOUTS

$$Q_{e, \max} = \frac{n_e Q_c \exp(-q_c T)}{1 - \exp(-q_c T_0)}$$

CAPACITY FOR SINGLE LANE  
CIRCULATING FLOW ROUNDABOUTS

$$Q_{e, \max} = \frac{n_e Q_c (1 - q_c t_d) \exp[-q_c (T - t_d)]}{1 - \exp(-q_c T_0)}$$

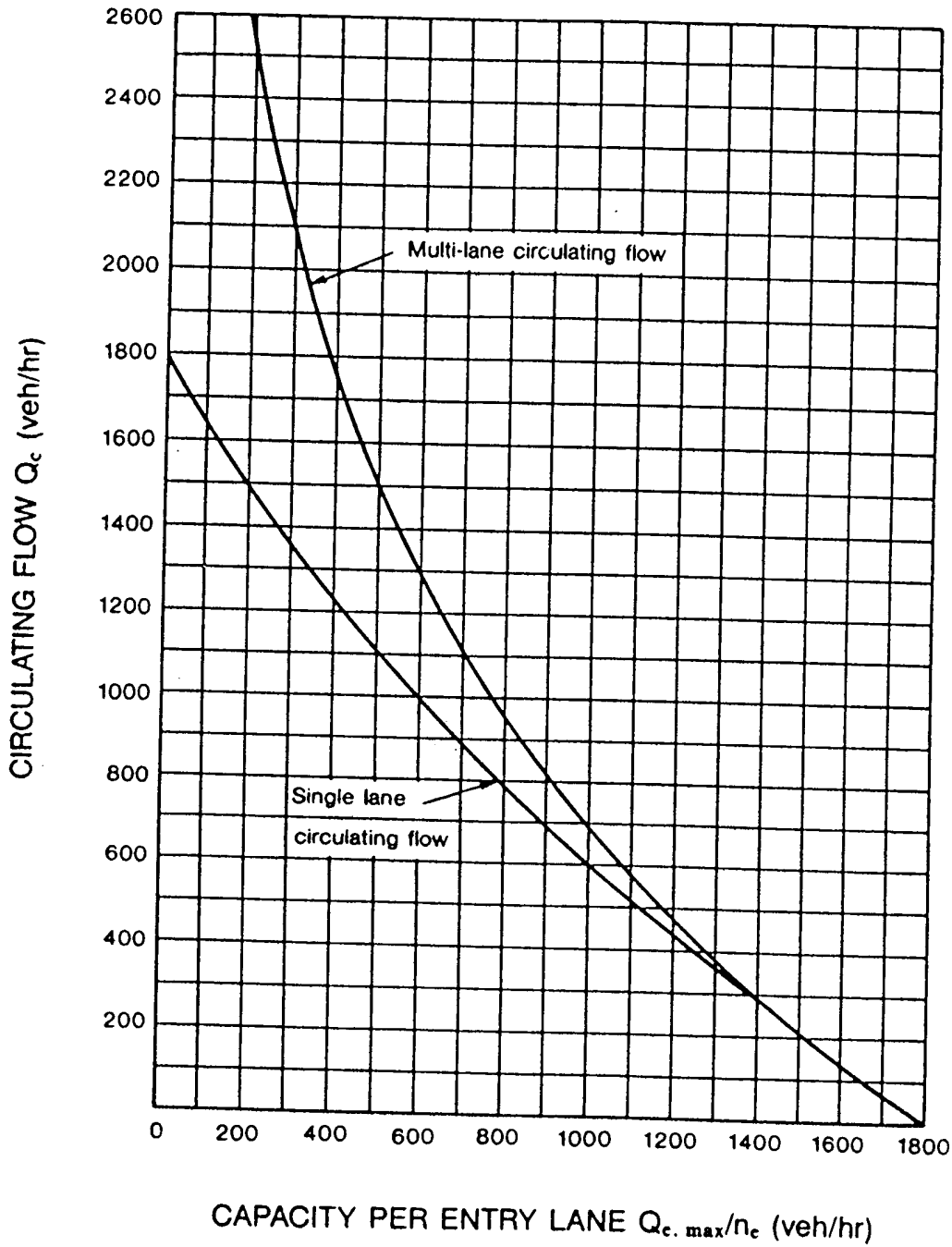

Figure 6.3: Relationship between Entry and Circulating Traffic Volumes (Avent 1979)

From Troutbeck's study, the concept of dominant and subdominant streams was introduced. This concept is purposely used to take into account the difference in each lane. The dominant stream is defined as the stream that has the greatest entry flow. Drivers in this stream have lower critical gap parameters, which result in a higher entry lane capacity. Drivers in the other entry streams (the subdominant streams) at the same leg have larger critical gap parameters. These streams also have a lower capacity. There is only one dominant stream at each entry, but there may be many subdominant streams. If there is only one entry stream, it will be a dominant stream (*Troutbeck 1990*).

Troutbeck developed new equations to calculate the critical gap and follow-up time in each lane. These equations are used in the Austroad design guideline. The follow-up time in the dominant stream,  $T_{odom}$ , can be computed by:

$$T_{odom} = 3.37 - 0.000394Q_c - 0.0208D_i + 0.0000889 D_i^2 - 0.395n_e + 0.388n_c \quad (6.12)$$

where

$Q_c$  = circulating flow (veh/hr)

$D_i$  = inscribed diameter, the largest diameter that can be drawn inside a roundabout

$n_e$  = number of entry lanes

$n_c$  = number of circulating lanes

The follow-up times for the subdominant stream,  $T_{osub}$ , were a function of the dominant stream follow-up time values and the ratio of the dominant stream entry flow,  $Q_{dom}$ , to the subdominant stream entry flow,  $Q_{sub}$ .

$$T_{osub} = 2.149 + 0.5135T_{odom} \frac{Q_{dom}}{Q_{sub}} - 0.8735 \frac{Q_{dom}}{Q_{sub}} \quad (6.13)$$

The larger the dominant stream follow-up time, the larger is the subdominant stream follow-up time. The dominant stream follow-up time also increases with larger variations in the lane entry flows.

The critical gap is dependent on the follow-up time, the circulating flow, the number of circulating lanes, and the average entry lane width,  $e_e$ . An expression for the ratio of the critical gap,  $T$ , to the follow-up time,  $T_0$ , was found to decrease with an increased circulating flow, the number of circulating lanes, and the average entry lane width. This equation was applied to the conditions in all entry lanes.

$$\frac{T}{T_0} = 3.6135 - 0.0003137Q_c - 0.3390 e_e - 0.2775n_c \quad (6.14)$$

Tables 6.3 to 6.7 give the tabulated values used in the Austroad guidelines calculated from the formula above for both the dominant and subdominant streams (*Troutbeck 1989*).

**Table 6.3: Dominant Stream Follow-up Headways ( $T_{0dom}$ ). (Initial values in seconds) (Troutbeck 1989)**

Inscribed Diameter (m)	Circulating flow (veh/h)					
	0	500	1000	1500	2000	2500
20	2.99	2.79	2.60	2.40	2.20	2.00
25	2.91	2.71	2.51	2.31	2.12	1.92
30	2.83	2.63	2.43	2.24	2.04	1.84
35	2.75	2.55	2.36	2.16	1.96	1.77
40	2.68	2.48	2.29	2.09	1.89	1.70
45	2.61	2.42	2.22	2.02	1.83	1.63
50	2.55	2.36	2.16	1.96	1.76	1.57
55	2.49	2.30	2.10	1.90	1.71	1.51
60	2.44	2.25	2.05	1.85	1.65	1.46
65	2.39	2.20	2.00	1.80	1.61	1.41
70	2.35	2.15	1.96	1.76	1.56	1.36
75	2.31	2.11	1.92	1.72	1.52	1.33
80	2.27	2.08	1.88	1.68	1.49	1.29

Note: The values of the follow-up headway are given to two decimal places to assist in interpolation. The adopted value may be rounded to one decimal place.

◦ Flows above about 1700 vph are not applicable to single lane circulating roadway (shaded area in table).

◦ The ratio of the critical acceptance gap to the follow-up headway ( $T_{dom}/T_{0dom}$ ), is given in Table 6.4.

The critical acceptance gap is the product of the appropriate values from Table 6.3 and Table 6.4.

**Table 6.4: Ratio of Critical Acceptance Gap to Follow-up Headway ( $T_{dom}/T_{0dom}$ ) (Troutbeck 1989)**

Number of circulating lanes	One			More than one		
	3	4	5	3	4	5
Average entry lane width (m)						
Circulating flow (veh/h)						
0	2.32	1.98	1.64	2.04	1.70	1.36
200	2.26	1.92	1.58	1.98	1.64	1.30
400	2.19	1.85	1.52	1.92	1.58	1.24
600	2.13	1.79	1.45	1.85	1.51	1.18
800	2.07	1.73	1.39	1.79	1.45	1.11
1000	2.01	1.67	1.33	1.73	1.39	1.10
1200	1.94	1.60	1.26	1.67	1.33	1.10
1400	1.88	1.54	1.20	1.60	1.26	1.10
1600	1.82	1.48	1.14	1.54	1.20	1.10
1800				1.48	1.14	1.10
2000				1.41	1.10	1.10
2200				1.35	1.10	1.10
2400				1.29	1.10	1.10
2600				1.23	1.10	1.10

◦ For single lane circulation roadways, if the critical gap calculation from Tables 6.3 and 6.4 is less than 2.1 s, use 2.1 s.

◦ For multi-lane circulating roadways, the minimum value of critical gap should be 1.5 s.

Note: Values of the ratio may be interpolated for intermediate widths of entry lane.

**Table 6.5: Adjustment Times for the Dominant Stream Follow-up Headway (Troutbeck 1989)**

Number of Circulating Lanes	Number of entry lanes		
	1	2	3
1	0.00	-0.39	-
2	0.39	0.00	-0.39
3	-	0.39	0.00

Note: Add or subtract these factors from the initial values from Table 6.3

**Table 6.6: Sub-dominant Stream Follow-up Headway  $T_{0sub}$  (Troutbeck 1989)**

Dominant Stream Follow-up Headway $T_{0dom}$ (s)	Sub-dominant follow-up headway ( $T_{0sub}$ ) (s)				
	Ratio of flows Dominant flow/Sub-dominant flow				
	1.0	1.5	2.0	2.5	3.0
1.5	2.05	1.99	1.94	1.89	1.84
1.6	2.10	2.07	2.05	2.02	1.99
1.7	2.15	2.15	2.15	2.15	2.15
1.8	2.20	2.23	2.25	2.28	2.30
1.9	2.25	2.30	2.35	2.40	2.46
2.0	2.30	2.38	2.46	2.53	2.61
2.1	2.35	2.46	2.56	2.66	2.76
2.2	2.41	2.53	2.66	2.79	2.92
2.3	2.46	2.61	2.76	2.92	3.07
2.4	2.51	2.69	2.87	3.05	3.23
2.5	2.56	2.76	2.97	3.17	3.38
2.6	2.61	2.84	3.07	3.30	3.53
2.7	2.70	2.92	3.17	3.43	3.69
2.8	2.80	3.00	3.28	3.56	3.84
2.9	2.90	3.07	3.38	3.69	4.00
3.0	3.00	3.15	3.48	3.82	4.15

**Table 6.7: Average Headway Between Bunched Vehicles in the Circulating Traffic ( $\Delta$ ) and the Number of Effective Lanes in the Circulating Roadway (Troutbeck 1989)**

Circulating Flow	Circulating Roadway Width			
	Less than 10 m		Greater than or equal to 10 m	
	Number of effective lanes	Headway between vehicles ( $\Delta$ ) (s)	Number of effective lanes	Headway between vehicles ( $\Delta$ ) (s)
<1000 veh/h	1	2	2	1
>1000 veh/h	1 (or 2)	2 (or 1)	2	1

**Table 6.8: Proportion of Bunched Vehicles,  $\theta$  (Troutbeck 1989)**

Number of effective circulating lanes	One	More than one
Average headway between bunched vehicles, $\Delta$ (s)	2.0	1.0
Circulating flow (veh/h)		
0	0.250	0.250
300	0.375	0.313
600	0.500	0.375
900	0.625	0.438
1200	0.750	0.500
1500	0.875	0.563
1800	1.000	0.625
2000		0.667
2200		0.708
2400		0.750
2600		0.792

### 6.1.2.2 German Gap Acceptance Capacity Formula

Ning Wu modified the basic idea from Tanner and proposed the following formula for estimating the capacity of an entry to a roundabout (*Brilon, Wu and Bonzio 1997*):

$$Q_e = \left(1 - \frac{\Delta Q_c}{n_c}\right)^{n_c} \cdot \frac{n_e}{T_o} \cdot e^{-Q_c \cdot (t_0 - \Delta)} \quad (6.15)$$

where

$Q_e$  = maximum entry capacity

$Q_c$  = circulating flow

$n_c$  = number of circulating lanes

$n_e$  = number of entry lanes

$$t_0 = T - \frac{T_o}{2}$$

$T$  = critical gap

$T_o$  = follow-up time

$\Delta$  = minimum headway between vehicles in the circulating lanes

## 6.2 THE STUDY OF DELAY FORMULAS

Delays at roundabouts consist of queuing delay and geometric delay. Queuing delay is the delay of vehicles waiting in queue. Geometric delay is the delay caused by the existence of the roundabouts.

Two delay formulas are described below, the UK and Australian formulas. The summary of the UK delay formula is based on the article by Marie C Semmens in 1985. The Australian delay formula is summarized from articles by Avent and Taylor and by R.J. Troutbeck.

## 6.2.1 The UK Delay Equation

### 6.2.1.1 Queuing Delay

The queuing delay equation is based on the Kimber and Hollis equation of 1979. Kimber and Hollis developed the equation using the time-dependent queuing approach. The basis of this method is to consider the probability distribution of different queue lengths as functions of time and, from these probabilities, to determine the average queue length, which then is used to compute the average queuing delay. Since this method is costly in computer time, equations have been developed which give a good approximation to the average queues calculated from probabilistic theory.

Consider a short time interval,  $t$ , during which the demand flow,  $q$ , and capacity  $\mu$  (where  $\mu \equiv Q_e$ ), may be assumed to be approximately constant. There are several cases, depending on the ratio of flow to capacity  $\rho$ , ( $\rho=q/\mu$ ), and, if  $\rho < 1$ , on the relative values of  $L_0$  (the queue at the start of the time interval under consideration), and  $l$  ( $l=\rho/1-\rho$ ), the equilibrium queue length.

If  $F_n$  is a queuing function defined for  $x$  (a time variable) by:

$$F_n(x) = 0.5\{((\mu x(1-\rho)+1)^2 + 4\rho\mu x)^{\frac{1}{2}} - \{\mu x(1-\rho)+1\}\}$$

Then the average queue length,  $L$ , after a time,  $t$ , is given by the following expressions:

for  $\rho \geq 1$ :  $L(t) = F_n(t+t_0)$  where  $t_0 = L_0(L_0+1)/\mu(\rho(L_0+1)-L_0)$

for  $\rho < 1$ :

(a)  $0 \leq L_0 < l$ :  $L(t) = F_n(t+ t_0)$

where  $t_0 = L_0(L_0+1)/\mu(\rho(L_0+1)-L_0)$

(b)  $L_0 = l$ :  $L(t) = l$

(c)  $l < L_0 \leq 2l$ :  $L(t) = 2l - F_n(t+t_0)$

where  $t_0 = (2l-L_0)(2l-L_0+1)/\mu(\rho(2l-L_0+1)-(2l-L_0))$

(d)  $L_0 > 2l$ :  $L(t) = L_0 + (\rho - L_0/(L_0+1))\mu t$  if  $0 \leq t \leq t_c$   
 $= 2l - F_n(t-t_c)$  if  $t > t_c$

where  $t_c = (2l-L_0)/\mu(\rho - L_0/(L_0+1))$

Delay per unit time can be calculated by:

$$D = 1/t \int_0^t L(t)dt$$

Given the entry flow, the capacity (and hence the ratio of flow to capacity) for a time segment, and the queue length at the beginning of the segment, the queue length at the end of the segment is calculated. Time segments are treated sequentially by using the end

queue for one segment as the start queue for the next. Thus maximum delays can be determined. Generally, the queue at the beginning is assumed to be zero.

### 6.2.1.2 Geometric Delay

Geometric delay is the delay caused to vehicles due to the presence of a junction. It occurs because vehicles must reduce their speed to negotiate the junction. In the case of roundabouts, vehicles must also deviate from a direct path. This type of delay occurs to every vehicle at the junction, and is not dependent on time of day. Geometric delay is most noticeable in off-peak periods. In peak periods, queuing delay will usually be greater than geometric delay. An estimation of geometric delay is useful, however, if a more complete appraisal of operation is desired. The calculation is especially important in situations where roundabouts of different geometry are to be compared with one another. This method helps ensure that any reductions achieved in queuing delay are not outweighed by possible increases in geometric delay, which apply throughout the day.

An equation was developed by McDonald, Hounsell, and Kimber in 1984 (*Semmens 1985*) based on extensive observations on the public road. The delay for each vehicle making a particular movement is calculated as the difference between:

- (i) the time taken to travel through the junction between the points where deceleration begins and acceleration ends, and
- (ii) the time taken to travel between these two points in the absence of the junction.

Both depend on approach and departure speeds and on certain geometric parameters of the roundabout.

Geometric delay (sec) is equal to:

$$(V_A - JS)/a_{AB} + (V_D - JS)/a_{CD} + d_{BC}/JS - (d_1 + d_{AB})/V_A - (d_2 + d_{CD})/V_D \quad (6.16)$$

where

$V_A$ ,  $V_D$  are the approach and departure speeds respectively, measured at points where speeds are not influenced by the roundabout (m/s);

$JS$  is the speed within the roundabout (m/s);

$a_{AB}$  is the deceleration rate approaching the roundabout, and is given by

$$a_{AB} = 1.06(V_A - JS)/V_A + 0.23 \text{ m/s}^2;$$

$a_{CD}$  is the acceleration rate leaving the roundabout, and is given by:

$$a_{CD} = 1.11(V_D - JS)/V_D + 0.02 \text{ m/s}^2;$$

$d_{BC}$  is the distance traveled within the roundabout (m);

$d_1$ ,  $d_2$  are the distances between the center of the roundabout and the entry and exit respectively (m);

$d_{AB}$  is the distance over which the deceleration towards the roundabout takes place, and is given by:

$$d_{AB} = (V_A^2 - JS^2)/2 a_{AB} \text{ m};$$



$d_{CD}$  is the distance over which the acceleration away from the roundabout takes place, and is given by:

$$d_{CD} = (V_D^2 - JS^2) / 2 a_{CD} \text{ m};$$

For a left turn;

$$JS = 0.84(\sqrt{ER} + \sqrt{EXR}) \text{ m/s}$$

where ER, EXR are the entry and exit corner radii (m)

For a straight ahead movement, where  $0.5(ENA + EXA) \leq 20^\circ$ ;

$$JS = 0.47Y + 0.035SD - 1.18 \text{ m/s}$$

where ENA = Entry Angle (degrees)

EXA = Exit Angle (degrees)

$Y = 0.5(V_A + V_D)$  (m/s)

SD = Sight Distance

or, if sight distance is unknown,

$$JS = 0.40Y + 2.43 \text{ m/s}$$

For a right turn or straight ahead movement, where  $0.5(ENA + EXA) > 20^\circ$ ;

$$JS = 0.96\sqrt{D} + 2.03 \text{ m/s}$$

where D is inscribed circle diameter

If the calculated  $JS > V_A$ , then  $JS = V_A$  and  $d_{AB} = 0$ . Similarly, if  $JS > V_D$ , then  $JS = V_D$  and  $d_{CD} = 0$ . If  $JS > V_A$  AND if  $JS > V_D$ , then  $JS = 0.5(V_A + V_D)$ . If delay calculated is less than 0, then delay is 0. (see Figure 6.4).

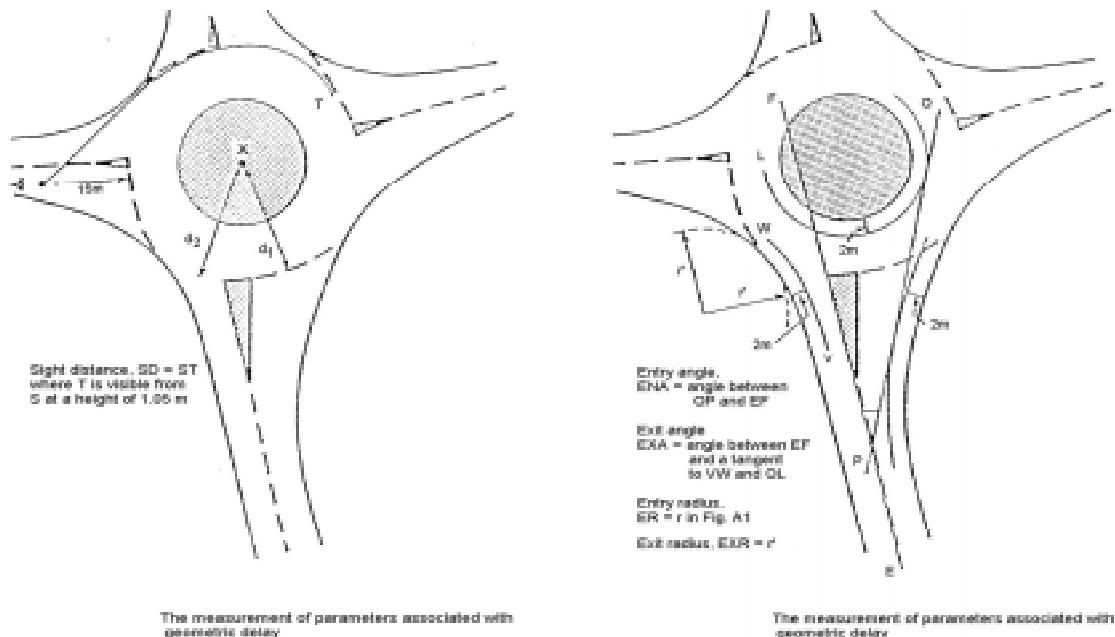

Figure 6.4: The Calculation of Geometric Delay (Semmens 1985)

## 6.2.2 The Australian Delay Formula

### 6.2.2.1 Queuing Delay

Similar to the capacity formula, the early Australian delay formula was adopted based on Tanner's delay equation with the gap parameters from the Avent and Taylor study in 1979. Tanner's delay equation was rearranged into an easier form by Dunne and Buckley as follows:

$$D = \frac{D_{min} + \eta x}{1-x} \quad (6.17)$$

where

$x$  = degree of saturation in the specified flow period, Entry flow/Entry Capacity  
 $D_{min}$  is called Adams delay which can be calculated from

$$D_{min} = e^{Q_c(T-\Delta)} - T - \frac{1}{Q_c} - \frac{\Delta^2 Q_c}{2} \quad (6.18)$$

and  $\eta$  was given by

$$\eta = \frac{e^{Q_c T_0} - Q_c T_0 - 1}{Q_c (e^{Q_c T_0} - 1)} \quad (6.19)$$

The minimum headway in the major stream was set to zero, implying a negative exponential headway distribution (Troutbeck 1992).

Because the new capacity formula by Troutbeck (Equation 6.11) is based on the dichotomized headway distribution, Troutbeck rederived Adams delay with dichotomized headway distribution. The new delay formula is:

$$D_{min} = \frac{e^{\lambda(T-\Delta)}}{Q_c \alpha} - T - \frac{1}{\lambda} - \frac{\lambda \Delta^2 - 2\Delta + 2\Delta \alpha}{2(\Delta \alpha + \alpha)} \quad (6.20)$$

Both Tanner's and Troutbeck's equations assumed zero queue length at the arrival of vehicles. Troutbeck also modified his formula taking into account the delay due to the presence of queue at the entry lanes. The average delay is then:

$$D = D_{min} + \frac{3600kx}{Q_e(1-x)} \quad (6.21)$$

where

$$k = \text{delay parameter given by } k = \frac{D_{min} Q_e}{3600}$$

$x$  = degree of saturation in the specified flow period, entry flow/entry capacity  
 $Q_e$  = entry lane capacity (veh/h)

All of the above formula represent a steady-state delay model. To get a better result, Akcelik and Troutbeck modified the model with a new time-dependent delay model. The new equation is:

$$D = D_{\min} + 900 \left[ Z + \sqrt{Z^2 + \frac{8kx}{Q_e H}} \right] \quad (6.22)$$

where

$H$  = flow period in hours

$x$  = degree of saturation in the specified flow period, entry flow/entry capacity

$Z = x - 1$

This formula was adopted in the Austroad Design Guideline (1993) with the substitution of  $8k$  to a new parameter  $m$ .

### 6.2.2.2 Geometric Delay

There are two components of geometric delay experienced at roundabouts. First is the delay of stopped vehicles and second is the delay of vehicles that do not have to stop. The first delay will be longer. The NAASRA Design Guideline (1986) gave the delay value for both types of vehicles. These delays were originally calculated in VicRoads by George (1982) who assumed that drivers accelerated at  $1.2 \text{ m/s}^2$  ( $4 \text{ ft/s}^2$ ) and decelerated at  $1.8 \text{ m/s}^2$  ( $6 \text{ ft/s}^2$ ) (Troutbeck 1990). Figure 6.5 gives the definition of terms used to determine the geometric delays. The delay values are shown in Tables 6.9 and 6.10.

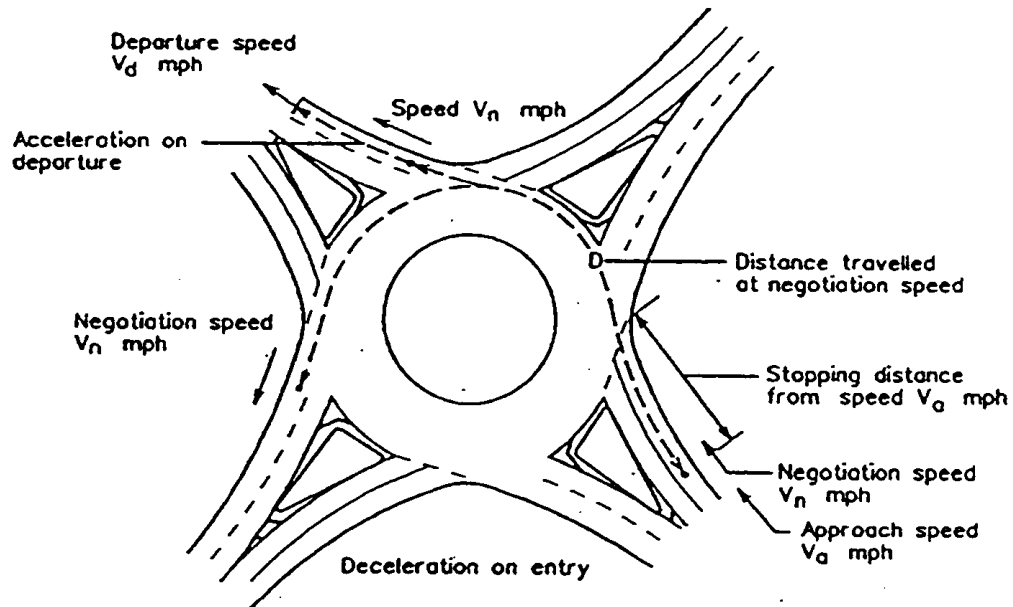

Figure 6.5: Definition of the Terms Used in Table 6.9 and 6.10 (Troutbeck 1989)

**Table 6.9: Geometric Delay for Stopped Vehicles (Seconds per vehicle) (Troutbeck 1989)**

Approach Speed $V_a$ (km/h)	Distance Around Roundabout $D$ (m)	Negotiated Speed Through Roundabout $V_n$ (km/h)							
		15	20	25	30	35	40	45	50
40	65	10	8	7	7	7			
40	195	19	15	12	9	7			
40	325		22	17	13	10			
40	460				18	14			
40	590					18			
60	65	13	11	10	10	10	10	10	10
60	195	23	18	15	13	10	10	10	10
60	325		26	21	18	15	12	10	10
60	460				22	19	15	12	10
60	590					23	19	15	10
80	65	17	15	13	13	13	13	13	13
80	195	26	22	19	17	14	13	13	13
80	325		29	25	21	19	16	13	13
80	460				26	23	19	16	13
80	590					27	23	19	16
100	65	20	18	17	17	17	17	17	17
100	195	30	25	22	20	18	17	17	17
100	325		33	28	25	22	20	17	17
100	460				30	26	23	20	17
100	590					3	27	24	20

(\* Refer to Figure 6.5 for the definitions of the dimensions.)

Another required parameter is the proportion of stopped vehicles. The proportion of stopped vehicles depends on two factors. First, the probability of being stopped increases as the traffic on the major road increases. The probability of being stopped is also proportional to the degree of saturation on the minor road. If the degree of saturation is high, there will be heavy queuing, increasing the probability of being stopped. Calculating the probability of being stopped will depend on both factors. This probability was obtained by the gap acceptance simulation and is given in Figure 6.6 and 6.7.

The average geometric delay is determined by:

$$D_G = P_s D_s + (1 - P_s) D_u$$

where

- $P_s$  = the proportion of stopped vehicles
- $D_s$  = the geometric delay of stopped vehicles
- $D_u$  = the geometric delay of vehicles which need not stop

**Table 6.10: Geometric Delay for Vehicles which Do Not Stop (Seconds/vehicle) (Troutbeck 1989)**

Approach Speed $V_a$ (km/h)	Distance around roundabout $D$ (m)	Negotiated speed through roundabout $V_n$ (km/h)							
		15	20	25	30	35	40	45	50
40	20	7	4	2	1	0			
40	60	17	11	7	4	0			
40	100		19	13	8	4			
40	140				13	8			
40	180					12			
60	20	11	8	5	4	3	2	1	1
60	60	20	15	11	8	4	2	1	1
60	100		22	17	13	9	5	1	1
60	140				17	13	8	4	1
60	180					17	12	7	2
80	20	14	11	9	7	6	5	4	3
80	60	24	19	15	11	8	5	4	3
80	100		26	20	16	13	9	5	3
80	140				21	17	13	9	4
80	180					21	16	12	7
100	20	18	15	12	10	9	8	7	6
100	60	27	22	18	15	12	9	7	6
100	100		29	24	20	16	13	10	6
100	140				25	20	17	13	12
100	180					25	20	16	

(\* Refer to Figure 6.5 for the definitions of the dimensions)

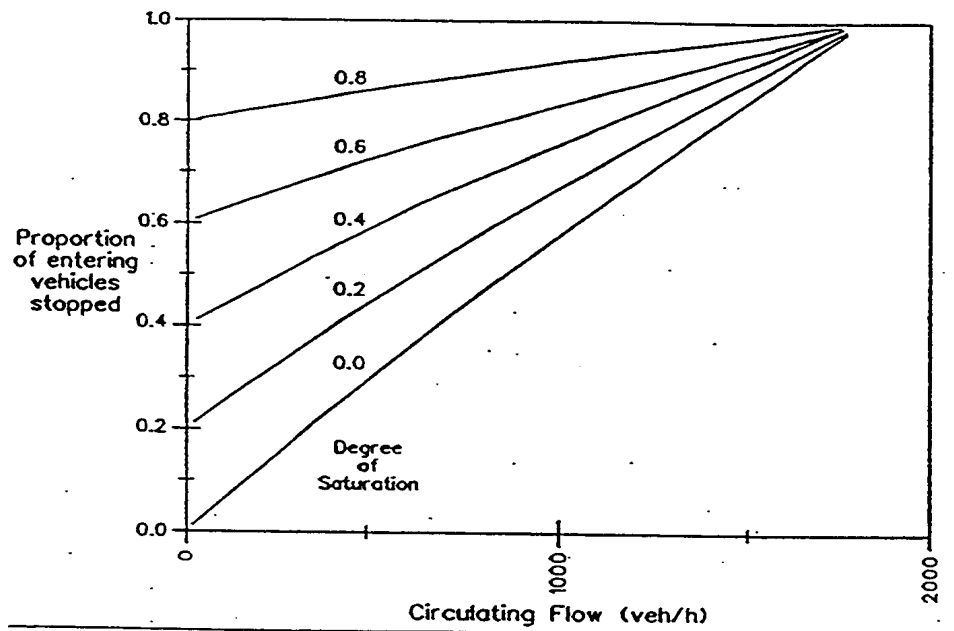

Figure 6.6: Proportion of Vehicles Stopped on a Single Lane Roundabout

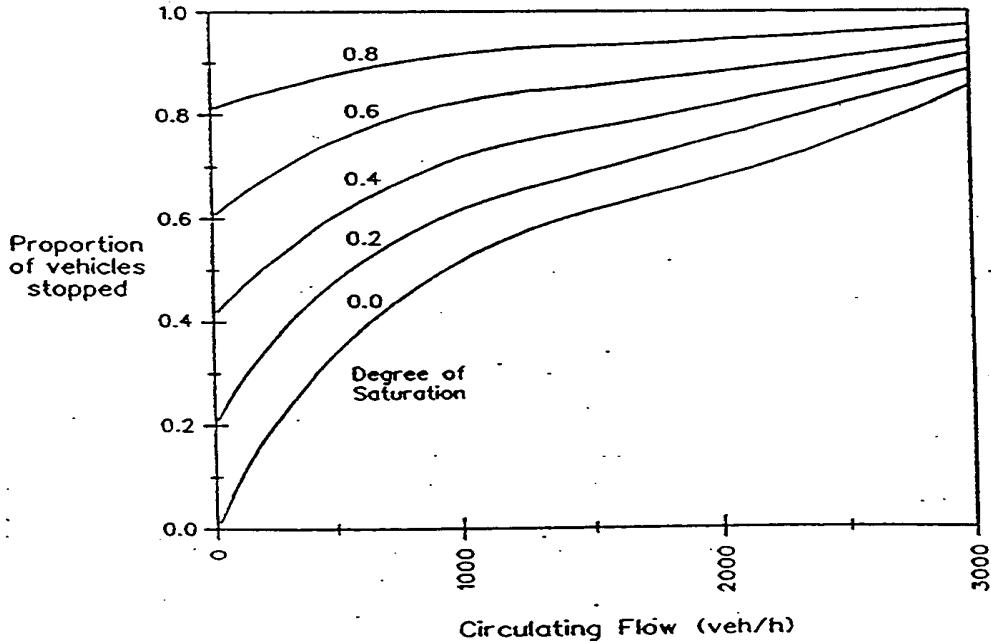

Figure 6.7: Proportion of Vehicles Stopped on a Multi-Lane Entry Roundabout (*Austrad 1993*)

## 6.3 THE CAPACITY OF ROUNDABOUTS IN THE US

This section summarizes the study of roundabouts in the US by Flannery and the proposed capacity formula in the new Highway Capacity Manual.

### 6.3.1 Capacity Studies in the US

Aimee Flannery (*Flannery and Datta 1996, 1997*) is conducting research to evaluate the operational performance of roundabouts in the US. Four roundabouts have been observed; three in Florida and one in Maryland. The description of study sites is shown in Table 6.11.

**Table 6.11: Site Characteristics** (*Flannery 1997*)

Site Locations	Circulating flows (all approaches)	Inscribed Circle Diameter	Entry Lane Width
Palm Beach County, FL	350 vph	30.5 m (100')	4 m (13')
Lisbon, Maryland	350 vph	30.5 m (100')	4 m (13')
Bradenton Beach, Florida	600 vph	20.1 m (66')	4 m (13')
Boca Raton, Florida	900 vph	48.8 m (160')	4 m (13')

Flannery's study focuses on a gap acceptance method to evaluate roundabout capacity. The primary reason for choosing gap acceptance was the lack of variety among the geometric features of the four sites. Developing the relationships between capacity and geometric features through regression analysis (the UK method) requires large sample sizes ranging between 16-35 sites.

In addition, the gap acceptance method is also becoming an accepted and promoted method of analysis among researchers in the US.

Two gap acceptance parameters, critical gap and follow-up time, were collected and analyzed from video record. The maximum likelihood technique was used to determine the critical gap, which was found to be 3.89 seconds. Flannery also compared the obtained parameters with the values computed from Austroads. The comparison is shown in Table 6.12.

**Table 6.12: Findings Comparison** (*Flannery 1997*)

Site Locations	Australian Recommended Follow-up Time (sec)	Average US Follow-up Time (sec)	Australian Recommended Critical Gap (sec)	Calculated US Critical Gap (sec)
Palm Beach County, FL	2.69	2.25	5.11	3.45
Lisbon, Maryland	2.69	2.82	5.11	4.03
Bradenton Beach, Florida	2.75	2.45	4.92	4.44
Boca Raton, Florida	2.20	2.38	3.74	3.84

The conclusions of her study are:

- The critical gaps determined from this study of four US roundabouts, based on the gap acceptance theory, are lower in three of the four sites as compared to the critical gap determined using the Austroads method.
- The average follow-up time observed as part of this study was lower in three of the four sites than the follow-up time determined using Austroads.
- The gap acceptance distribution at roundabouts generally follows the same shape and similar slope when plotted on logarithmic/probabilistic graphs, as compared to gap acceptance characteristics of traditional two-way stop controlled intersections. However, the mean of the gap acceptance distribution is smaller for roundabouts than the mean of the distribution for right turning vehicles at traditional stop controlled intersections.

### 6.3.2 Capacity Formula Use in US Roundabout Guidelines

Maryland follows the Austroad capacity and delay formula, while Florida recommends using the SIDRA program developed by Australia to analyze roundabout performances. No recommendation of capacity is made in the California design guidelines.

### 6.3.3 Proposed Formula in the New Highway Capacity Manual

As roundabouts involve drivers making a right turn onto the roundabout, the gap acceptance characteristics of drivers are expected to be the same or similar to drivers making right turns at Two Way Stop Control (TWSC) intersections (*Kyte 1997*).

The proposed capacity formula is:

$$Q_e = \frac{Q_c e^{-Q_c T / 3600}}{1 - e^{-Q_c T_0 / 3600}} \quad (6.22)$$

where

$Q_e$  = approach capacity (vph)

$Q_c$  = conflicting circulating traffic (vph)

$T$  = critical gap (s)

$T_0$  = follow-up time (s)

Critical gap and follow-up time are shown in Table 6.13.

**Table 6.13: Critical Gaps and Follow-up Times (Kyte 1997)**

	Critical gap (sec)	Follow-up time (sec)
Upper bound Solution	4.1	2.6
Lower bound Solution	4.6	3.1

## 6.4 DISCUSSION

Roundabout capacity can be calculated using gap acceptance and regression approaches. Table 6.14 summarizes some differences of the two approaches. The assumption of the gap acceptance theory is that drivers are consistent and homogeneous. Many studies have proven that this assumption is not proper in every circumstance and results in errors in capacity prediction. At low traffic flow, capacity will be overestimated. Capacity will be underestimated at high traffic flow. The single value estimators of both critical gap and follow-up time need to be adjusted.

**Table 6.14: Summary of Gap Acceptance Method and Empirical Method**

Criteria	Gap Acceptance	Empirical
Methodology	<ul style="list-style-type: none"> <li>-Theoretical Basis.</li> <li>-Represent driver behavior based on vehicle-vehicle interaction.</li> <li>-The use of single estimators of critical gap and follow-up time is questionable for the accuracy of capacity prediction.</li> </ul>	<ul style="list-style-type: none"> <li>-Statistical Regression Basis.</li> <li>-Imply driver behavior by the relationship between geometric elements and road performances.</li> <li>-Some geometric parameters may prove to be statistically significant, but cannot be explained logically.</li> </ul>
Data Acquisition to Develop the Models	<ul style="list-style-type: none"> <li>-Under the simplified assumption of gap acceptance theory, less amount of data is required.</li> <li>-When model gets complicated, method to obtain and verify data seems to get complicated as well.</li> </ul>	<ul style="list-style-type: none"> <li>-Requires an extensive amount of data with the sufficient variation of each parameter.</li> </ul>
Reliability of Prediction	<ul style="list-style-type: none"> <li>-Depends on the developed model and assumptions.</li> </ul>	<ul style="list-style-type: none"> <li>-Depends on the methods of sampling and sample sizes.</li> </ul>
Simplicity	<ul style="list-style-type: none"> <li>-Easy for planning purposes.</li> </ul>	<ul style="list-style-type: none"> <li>-Easy for geometric design purposes.</li> </ul>

To illustrate the differences in the formula used by each country, a problem was set up to compute capacities using each formula. A four-legged single-lane roundabout has Inscribed Circle Diameter 50 m, Entry width 5m, Approach half width 4.5 m, Circulating width 5 m, Effective length (l) 30 m, Entry radius 40 m, and Entry angle 60 degree. The calculated capacities are shown in Table 6.15 and Figure 6.8. The circulating flows are varied from 0-1500 vph. As Table 6.15 shows, the UK formula seems to give a very high capacity. This can be explained by the design philosophy of roundabouts in the UK. The smaller central island, less deflection, and wide entry with flare allow drivers to drive faster, resulting in the capacity increase. However, the UK design might result in higher accident rates.



The Australian capacity formula attempted to resolve the shortcomings of the gap acceptance technique, for example, by incorporating the variation of critical gap and follow-up time with different volumes of traffic. The Australian formula illustrates that both gap parameters should vary with circulating flow volume. Moreover, in Troutbeck's formula, the gap parameters are related to the geometric variations.

As can be seen on Table 6.15, the new linear regression German formula (G2) gives higher values than the exponential regression (G1) at low circulating flow. This might be explained by the fact that the exponential formula was developed while the German drivers still were not familiar with roundabouts. This causes drivers to drive slower and more cautiously.

At high circulating flow, two possible answers can be used to explain the lower capacity values with the new linear regression model. The first explanation is that both models may have less predictability when circulating flows are close to or higher than capacity. The second is the problem of sample size. The first formula was developed when few modern roundabouts were built and probably only a few were built at high circulating flows. When more data were obtained, the statistical significance was improved.

The UK and both German formulas are based on empirical approach. However, the difference in capacity estimation is identified in the example shown in Table 6.15. Even though Birgit Stuwe explained the differences in terms of German drivers being unfamiliar with the new roundabouts, the computed values still have a wide difference. This may be answered by the same reason given in the previous discussion, where different design philosophies were used.

**Table 6.15: Entering Capacity Comparison**

<b>Q<sub>c</sub></b>	<b>UK</b>	<b>G1</b>	<b>G2</b>	<b>USu</b>	<b>USl</b>	<b>Aust</b>
0	1539	1089	1218	0	0	0
100	1481	1011	1144	1067	1280	1321
200	1422	939	1070	979	1184	1248
300	1364	872	996	898	1094	1176
400	1305	809	922	823	1011	1126
500	1247	751	848	754	933	1061
600	1189	698	774	690	861	1005
700	1130	648	700	632	794	945
800	1072	601	626	578	733	891
900	1013	558	552	528	675	818
1000	955	518	478	482	623	768
1100	897	481	404	440	573	699
1200	838	447	330	402	527	633
1300	780	415	256	366	485	556
1400	721	385	182	334	446	469
1500	663	357	108	304	411	373

Note: Q<sub>c</sub> = Circulating flow (vph); UK = Eq. 6.6; G1 = Eq. 6.7; G2 = Eq. 6.8; USu = Eq. 6.22 upper bound; USl = Eq. 6.22 lower bound; Aust = Eq. 6.11.

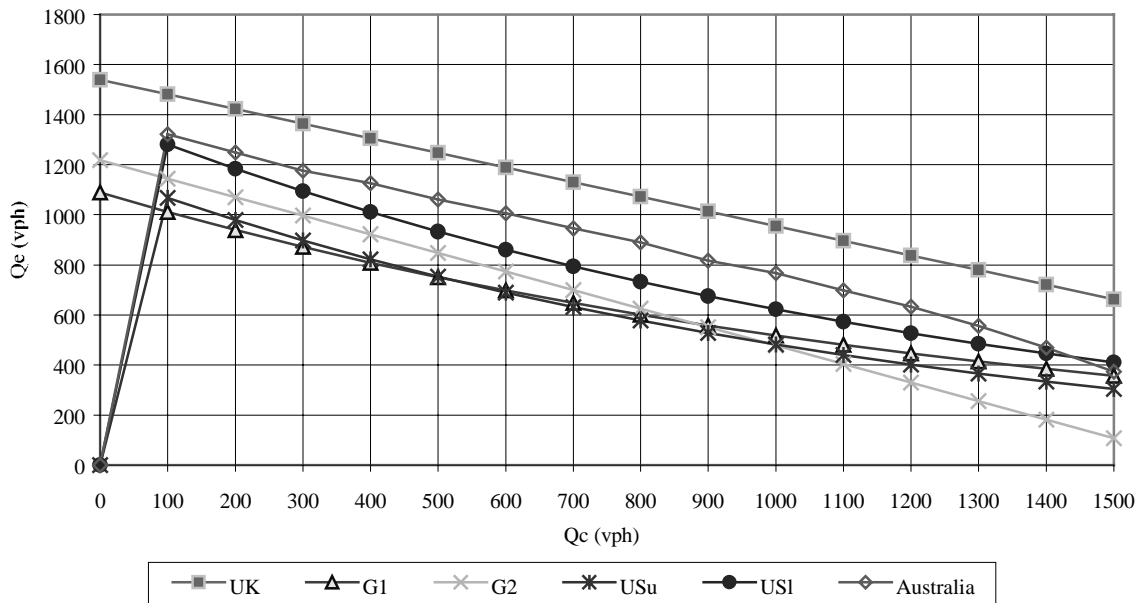

Figure 6.8: Comparison of Capacity Formulas

Table 6.16 lists the comparison between two gap acceptance formulas. It should be noted that the Australian formula was much more complicated than the method used in the US. Every difference in the assumptions and given equations will have a varied effect on the capacity prediction. Some parameters in the Australian formula were developed specifically for Australian conditions. The use of the Cowan M3 Distribution to describe the flow distribution in a traffic stream needs to be properly evaluated for US conditions.

**Table 6.16: Comparison of the Australia and US Capacity Formula**

Category	Australia	US
Methodology	Gap Acceptance	Gap Acceptance
Parameters	Critical Gap, Follow-up time	Critical Gap, Follow-up time
Parameters Determination	Equation developed by the study of Troutbeck	Upper and Lower Values from the study in the US
The relationship between parameters and geometries	Inscribed Circle Diameter, Number of lanes	N/A
Traffic flow distribution	Cowan M3 Distribution	Exponential Distribution
Application for multi-lane	Apply in terms of subdominant and dominant flows	Not recommended

## 6.5 RECOMMENDATIONS FOR FURTHER CONSIDERATION

The current measures to assess roundabout performance are capacity and delay. This chapter reviewed some of the potential capacity and delay formulas that might be suitable for use in Oregon. Formulas from both the US and other countries were investigated.

Since ODOT uses the volume/capacity ( $v/c$ ) ratio to evaluate intersection performance, more attention is paid to the capacity formula. Moreover, both of the delay formulas presented in this chapter require a  $v/c$  ratio for computation. The comparisons of each capacity formula are investigated, but certain conclusions cannot yet be drawn. The UK capacity formula seems to give the highest values, while others lie within a range on the conservative side.

The operational characteristics of roundabouts are dictated by drivers' behavior and roundabout geometry, which are varied from place to place, and from design standard to design standard. Consequently, one formula should not be transferred without adjustment.

For future implementation in Oregon, three options are available to determine roundabout capacity:

- 1) Use the available capacity formulas.

This is a good temporary solution until further study is conducted. The lower bound US capacity formula is suggested for a single lane, low or middle volume roundabout. For multilane roundabouts, a conservative value from the Australian and German formula is recommended at this point since roundabouts are new for Oregon.

- 2) Wait for research results from the national study.

Currently, a national study is being conducted with funding support from FHWA. The research is expected to be complete in mid 1999 and is intended to present design guideline for general use in the US.

- 3) Develop a formula for Oregon.

As previously mentioned, the variation of drivers' behavior and roundabout geometry is important in the outcome of the capacity formula. Therefore, the research results from the national study might not be consistent with future Oregon design guidelines. An Oregon formula can be adopted from field experiment and simulation. Basic parameters, i.e., critical gap, follow-up time, and headway distribution can be collected from field experiments. Simulation software then can be used to generate the potential capacity and the appropriate formula can be determined.



## 7.0 SOFTWARE MODELS FOR ROUNDABOUTS

The purpose of this study was not to acquire or evaluate existing software used for developing roundabouts, but to obtain information on available resources for roundabout analysis and design. Most of information in this chapter came from articles by software users and developers.

Currently, three major software packages from other countries are used to analyze or design roundabouts in the US. The review of the SIDRA program and the comparison in section 7.4 are extracted from the Florida Roundabout Guide. The description of RODEL and ARCADY is from the book by Mike Brown. Section 7.5 introduces some new software packages that should be explored for possible use in future designs of US roundabouts.

### 7.1 ARCADY

ARCADY (Assessment of Roundabout CAPacity and DelaY) was used as the primary model for evaluating roundabout performance in the UK. The first version was released in 1981. This program was developed by MVA Systematica under contract to Transport Road Research Laboratory (TRRL). In 1985, the second version (ARCADY2) was issued with an exclusive enhancement. The additional features incorporated in ARCADY2 are:

- Further ways of specifying demand flows, turning proportions and vehicle mix.
- The ability to model the effect of pedestrian volume at crossings.
- The ability to calculate geometric delays.
- The ability to calculate accident frequencies or indices.
- The ability to make local corrections to capacities.
- The extension to microcomputer and interactive versions

The capacity prediction of ARCADY was based on Kimber's formula as previously described in Chapter 6. Therefore, the input parameters include entry width, inscribed circle diameter, flare length, approach road width, entry radius, and the entry angle. The output for each time interval, consists of:

- Traffic and pedestrian demand flows.
- Capacity.
- The flow/capacity ratio (RFC).
- The queue lengths at the start and end of each interval.
- The queuing delay, and the geometric delay.

Comprehensive information on ARCADY2 is described in an article by Marie Semmens in 1985.

Another version (ARCADY3) was issued in 1990 with a revised comprehensive user guide by Webb and Pierce. The improvements of this version were described as (*Brown 1995*):

- 1) A method of predicting daily distribution of queue lengths was developed by Kimber, Daly, Barton & Giokas, based on the results of multiple runs of a simulation model. The time-varying nature of both the arrival of individual vehicles and their servicing (opportunities for them to discharge) will result in different evolutions of queue from day to day, even when the mean arrival rates and capacities are constant. There will also be variation in queue length for any particular time interval during the peak. This variation has been observed to result in queue lengths on an individual day ranging from close to zero to almost twice the mean value.

In many applications it is important to have some knowledge of the cumulative distribution of queue lengths - for example, what is the probability of a queue stretching back onto a motorway? Consideration of a range of typical peak flow and capacity profiles enabled two properties of the resulting daily queue length distributions to be derived, namely the type of underlying distribution, and its variance. ARCADY3 is able to predict the day to day variability of queues in addition to the mean length, and the user can obtain the likelihood of a queue to a specified critical point.

- 2) The prediction of the marginal effects in terms of accidents or capacity, of small changes in design parameters.
- 3) Revised treatment of very large and/or grade-separated roundabouts.
- 4) The program user can specify light conditions and adjustments will be made to the standard capacity calculations. Burrow reported in 1986 on the effect of darkness on the capacity of road intersections. This indicates that under typical conditions being modeled by ARCADY, capacities are reduced by five percent in conditions of darkness (i.e. the absence of natural light- all the roundabouts studied had adequate artificial lighting, the normal case for roundabouts modeled with ARCADY).

At the time of this research, the most recent version (ARCADY4) had been released. The only difference in this version is that ARCADY4 is a window-based environment, which will make the program more user-friendly.

## **7.2 RODEL**

RODEL (ROundabout DELay) is an interactive program intended for the evaluation and design of roundabouts. This program was developed in the Highway Department of Staffordshire County Council in the UK. RODEL is based on an empirical model similar to that of ARCADY, also developed by Kimber. The main difference is that the confidence level for the output may be specified for RODEL, but it is embedded in the ARCADY model at 50 percent. With RODEL, simultaneous display of both input and output data is shown in a single screen.

There are two main modes of operation. In mode 1, the user specifies a target parameter for average delay, maximum delay, maximum queue, and maximum RFC factor (flow/capacity ratio). RODEL generates several sets of entry geometrics for each approach based on the given input. Depending on site specifics and constraints, the generated geometrics can be used for design purposes. Mode 2 focuses more on performance evaluation using specified values of the

geometric and traffic characteristics. The data entry/edit screens for both modes are illustrated in Figure 7.1.

14:12:95		RND4020101L				55			
AVE DELAY	0.80	0.80	0.80	0.80	TIME PERIOD	min	60		
V (m)	3.70	3.70	3.70	3.70	TIME SLICE	min	15		
RAD (m)	20.00	20.00	20.00	20.00	RESULTS PERIOD	min	00 60		
PHI (d)	30.00	30.00	30.00	30.00	TIME COST	p/min	7.79		
DIA (m)	30.00	30.00	30.00	30.00	FLOW PERIOD	min	00 60		
GRAD SEP	0	0	0	0	FLOW TYPE	pcu/veh	VEH		
					FLOW PEAK	am/op/pm	OP		
LEG NAME	PCU	FLOWS (1st exit 2nd etc...U)				FLOF	CL	FLOW RATIO	FLOW TIME
SOUTH APR	1.02	20	140	40	0	1.00	85	0.75 1.125 0.75	15 45 60
EAST APR	1.02	30	210	60	0	1.00	85	0.75 1.125 0.75	15 45 60
NORTH APR	1.02	20	140	40	0	1.00	85	0.75 1.125 0.75	15 45 60
WEST APR	1.02	30	210	60	0	1.00	85	0.75 1.125 0.75	15 45 60
AVE DELAY mins		MODE 1a AVE DELAY				TOTAL DELAYS			
		0.09	0.10	0.09	0.10	2 hrs			
MIN ENTRY	E	3.70	3.70	3.70	3.70	9 pounds			
MAX FLARE	L'	0.00	0.00	0.00	0.00				
MAX ENTRY	E	16.40	16.40	16.40	16.40				
MIN FLARE	L'	0.00	0.00	0.00	0.00				
Flmode F2direct F3peak CtrlF3rev F4fact F5geom F6stat F8econ F9prnt F10run Esc									

. **RODEL mode 1 data entry screen.**

14:12:95		RND4020101L				54			
E (m)	5.00	5.00	5.00	5.00	TIME PERIOD	min	60		
L' (m)	10.00	10.00	10.00	10.00	TIME SLICE	min	15		
V (m)	3.70	3.70	3.70	3.70	RESULTS PERIOD	min	00 60		
RAD (m)	20.00	20.00	20.00	20.00	TIME COST	p/min	7.79		
PHI (d)	30.00	30.00	30.00	30.00	FLOW PERIOD	min	00 60		
DIA (m)	30.00	30.00	30.00	30.00	FLOW TYPE	pcu/veh	VEH		
GRAD SEP	0	0	0	0	FLOW PEAK	am/op/pm	OP		
LEG NAME	PCU	FLOWS (1st exit 2nd etc...U)				FLOF	CL	FLOW RATIO	FLOW TIME
SOUTH APR	1.02	20	140	40	0	1.00	85	0.75 1.125 0.75	15 45 60
EAST APR	1.02	30	210	60	0	1.00	85	0.75 1.125 0.75	15 45 60
NORTH APR	1.02	20	140	40	0	1.00	85	0.75 1.125 0.75	15 45 60
WEST APR	1.02	30	210	60	0	1.00	85	0.75 1.125 0.75	15 45 60
FLOW		MODE 2				TOTAL DELAYS			
	veh	223	335	223	335	1 hrs			
CAPACITY	veh	1029	1070	1029	1070	6 pounds			
AVE DELAY	mins	0.06	0.07	0.06	0.07				
MAX DELAY	mins	0.09	0.10	0.09	0.10				
AVE QUEUE	veh	0	0	0	0				
MAX QUEUE	veh	0	1	0	1				
Flmode F2direct F3peak CtrlF3rev F4fact F6stats F8econ F9prnt F10run Esc									

. **RODEL mode 2 data entry screen.**

Figure 7.1: Data Entry/Edit Screens for Both Modes of RODEL (Florida 1996)

## 7.3 SIDRA

The Australian Road Research Board (ARRB) developed the SIDRA (Signalized Intersection Design and Research Aid) program. The original purpose of SIDRA was to incorporate the power of computers with the design techniques from research studies by ARRB. Therefore, SIDRA has been updated or enhanced based on the new findings from field observations or new techniques developed from research studies. Presently, SIDRA can be used to estimate capacity and performance (delay, queue length, stops) for all types of intersections, including roundabouts.

The basic methods used in SIDRA 4.07 and the Austroad design guideline 1993 for analyzing the capacity and performance of roundabouts was based on ARRB Special Report 45 (SR45) (Troutbeck 1989). The most recent version, SIDRA 5.0, is an updated version of SIDRA 4.1 with minor refinements. Since SIDRA 4.1, the new concept of approach-flow interactions was introduced. The major features based on Austroad 1993 that are still being used in SIDRA and the enhancements are summarized in Table 7.1 and 7.2. Further discussions can be found in the ARR 321 research report (Akcelik 1998). These changes make the SIDRA approach different from that used in Austroad 1993, yielding more realistic results.

**Table 7.1: Main Features of the SIDRA Method for Roundabout Capacity Estimation**

---

Gap acceptance parameters are related to roundabout geometry as well as circulation and entry flows as follows:

- Entry stream *follow-up headway* decreases with
  - increasing diameter of the roundabout
  - increasing circulation flow (\*)
  - decreasing number of circulation lanes
  - increasing number of entry lanes
  
- *Mean critical gap* is proportional to the follow-up headway.  
The *ratio of the critical gap to the follow-up headway* is in the range 1.1 to 2.1, and decreases with increasing
  - circulation flow (\*)
  - number of circulating lanes
  - average entry lane width
  
- For multi-lane approach roads, the lane with the largest flow rate is called *dominant lane* and the other lanes are called *subdominant lanes*.
  - The minimum departure headway for traffic in a subdominant lane is greater than the minimum departure headway for the dominant lane traffic.
  - The ratio of minimum departure headways for the subdominant and dominant lanes increases as the ratio of dominant lane flow to subdominant lane flow increases (the mean ratio is 1.2).Thus, entry lane capacities depend on entry flows, requiring an iterative method to estimate lane flows and capacities.

Heavy vehicle effects are accounted for using the pcu factor method (Troutbeck 1991).

---

(\*) This implies that driver behavior patterns change with intersection geometry as well as increased circulation flows (more vehicles can depart through an acceptable gap, and shorter gaps are accepted). This confirms Kimber's (1989) observations. Enhancements introduced in later versions of SIDRA make the roundabout analysis method differ from a simple gap acceptance analysis.



**Table 7.2: Enhancements to Roundabout Analysis Method Introduced in SIDRA**

---

- Origin-Destination (O-D) pattern, approach queuing and approach lane usage affect entry lane capacities (roundabout is *not analyzed as a series of independent T-junctions*).
  - An iterative method is used to calculate
    1. the circulating flow (for entry lanes) and the exiting flow (for slip lanes) for each approach, and
    2. for each circulating and exiting flow, the proportion of heavy vehicles, proportion of queued vehicles from the dominant approach and proportions of vehicles in single and multi-lane streams.
  - *Capacity constraint* for oversaturated approaches is applied in determining circulating and exiting flow characteristics (only the capacity flow can enter the circulating road).
  - Gap acceptance parameters (critical gap and follow-up headway) are adjusted for heavy entry flows against low circulating flows.
  - Various limits are applied to the values of gap acceptance parameters.
  - Different critical gap and follow-up headways can be specified for different turns (left, through, right) from the same approach.
  - A proportion of exiting flow can be added to the circulating flow.
  - Intra-bunch headways and proportion bunched depend on effective lane use and lane flows in the circulating stream considering contributing approach streams.
  - Extra bunching for upstream signal effects are specified by the user for approach roads. SIDRA calculates effective extra bunching for each circulating stream according to the extra bunching specified and proportion unqueued calculated for each contributing approach stream.
  - Entry lane flows estimated as a function of lane capacities (iterative calculations are performed).
  - Lane under-utilization for entry lanes: Unequal approach lane utilization is allowed, e.g. for downstream destination effects.
  - Detailed lane-by-lane modeling of capacity and performance is applied (including fuel consumption, operating cost and pollutant emissions).
  - Short lane model is fully applicable through the use of back of queue formulation (*excess flow* is assigned to adjacent lanes when the average back of queue exceeds the available storage space in the short lane).
  - Slip lanes are modeled by treating the exiting flow as the opposing stream.
  - Time-dependent performance formulas are used for application to oversaturated cases.
  - Geometric delay method is consistent for all intersection types. The SIDRA method differs from the AUSTRROADS (1993) method in applying the geometric delays to queued and unqueued vehicles, and using different equations for geometric delays.
  - Performance estimates are given for delay (total delay, stopped delay, idling time and geometric delay), back of queue and cycle-average queue length (mean, 90<sup>th</sup>, 95<sup>th</sup> and 98<sup>th</sup> percentile values), queue move-up rate, effective stop rate, proportion queued and queue clearance time.
  - Consistency of capacity and performance analysis methods for roundabouts, other unsignalized intersections and signalized intersections is achieved through the use of an integrated modeling framework.
- 

SIDRA requires site-specific data covering traffic volumes by movement, number of entry and circulating lanes, central island diameters, and circulating roadway width. The default value for practical capacity of the roundabout (flow/capacity ratio) is 85 percent. As flow reaches capacity, the operational characteristics of a roundabout are less predictable. Therefore, both Austroad and SIDRA recommend a maximum value for the flow/capacity ratio of 0.85.

According to Austroad, delays at roundabouts consist of queuing delay and geometric delay. SIDRA offers the option to include or exclude the geometric delay from the computations.

## 7.4 COMPARISON OF ARCADY, RODEL AND SIDRA

Kenneth G Courage (*Florida 1996*) made comparisons between these three software models and gave the following conclusions:

- Even though both ARCADY and RODEL use Kimber's capacity formula, the results will be similar only when a 50 percent confidence level is specified on RODEL. On the other hand, SIDRA does not recognize this stochastic concept because it is an analytical model with a deterministic structure. It also notes that an 85 percent practical capacity in SIDRA is entirely different in meaning from 85 percent confidence level.
- Figure 7.2 shows an example of a volume-delay comparison between these three programs. The three curves shown on this figure to represent the volume/delay characteristics produced by RODEL at 50% (which also represents the ARCADY results), RODEL at 85% confidence level, and SIDRA. Higher delays are naturally predicted by RODEL at 85% confidence because of the definition of the confidence level. At low volumes, SIDRA estimates delays lower than RODEL at either confidence level. As volumes approach capacity, the SIDRA delays increase more rapidly and eventually appear about halfway between the 50% and 85% confidence levels for RODEL.

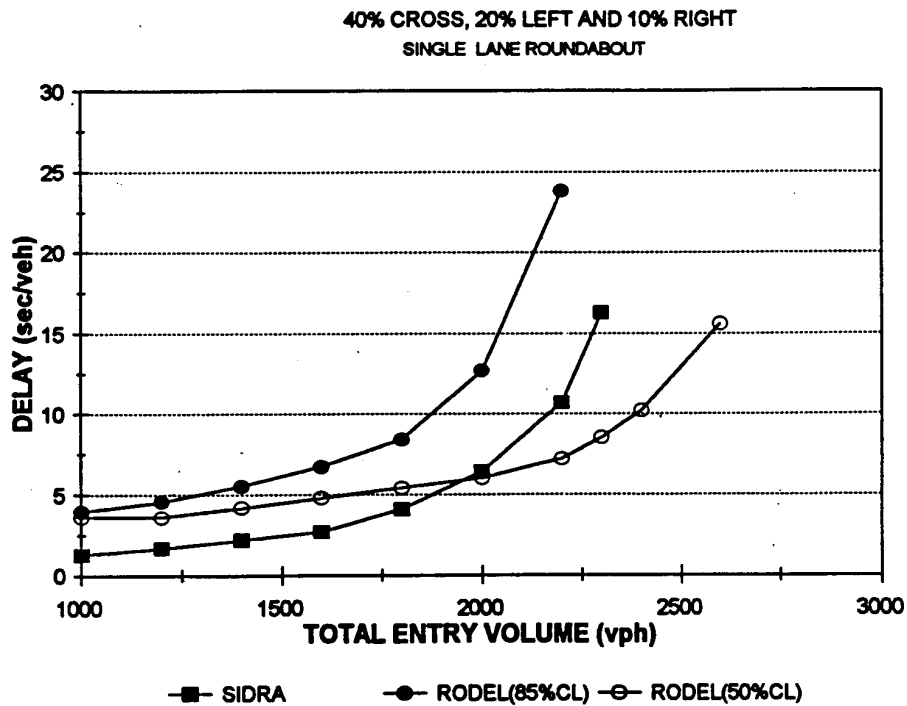

Figure 7.2: Volume-Delay Comparison (*Florida 1996*)

- SIDRA recognizes only two geometric parameters (central island diameter and circulating roadway width). Because inscribed circle diameter is the product of central island diameter and circulating roadway width, we can determine the inscribed circle diameter for SIDRA and compare it with RODEL. A comparison of the effect of inscribed circle diameter for both programs is illustrated for the sample problem in Figure 7.3. Note that SIDRA predicts lower capacities than RODEL (at the 85% confidence level) for smaller inscribed circle diameters and higher capacities than RODEL for larger inscribed circle diameters. The RODEL model recognizes an additional three entry parameters (width, angle, and radius). In some cases, these parameters have a substantial influence on the outcome estimated by RODEL.

## 7.5 OTHER SOFTWARE MODELS

**TRANSYT-7F** (*Florida 1996*) is a general signalized intersection network model that incorporates gap acceptance features similar to SIDRA. It should, in theory, be possible to construct an interconnected system of “YIELD” controlled intersections that would exhibit at least some of the characteristics of a roundabout from the perspective of TRANSYT-7F. An attempt by the developer to do this was not successful and it was concluded that the TRANSYT-7F model was not designed for this purpose and that the present version does not offer a useful roundabout modeling capacity.

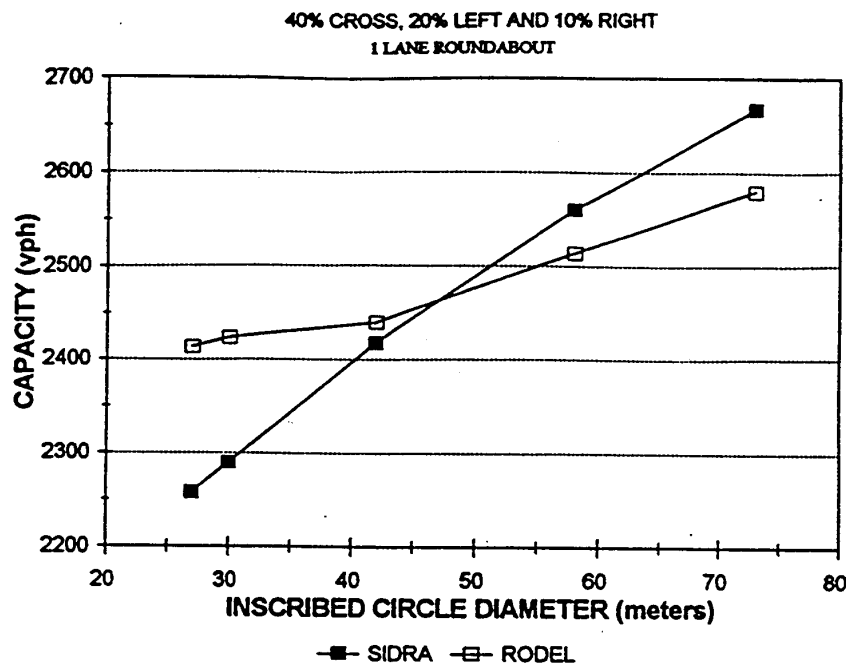

Figure 7.3: Effect of Inscribed Circle Diameters on RODEL and SIDRA Predicted Capacities (*Florida 1996*)

**NETSIM** (*Persula, Hangring and Niittymaki 1997*) is also a general traffic network model with the capability to model stop and yield control. An attempt to represent a roundabout as a network of interconnected yield signs met with some success, producing capacity and delay values in the same range as SIDRA and RODEL when the proportion of cross street traffic was

high. However, with very low cross street proportions (below 30%) the results could not be reconciled rationally. Some development work is now underway to improve the applicability of NETSIM to roundabout analysis. However, based on the results of this study, the current version of NETSIM cannot be recommended for this purpose.

**CORSIM** (*Courage 1997*) is a general network model that has been evolving for many years with the support of the USDOT. CORSIM recognizes all types of signalized and unsignalized controls. It is able to model yield-controlled intersections explicitly, and therefore has the implicit capability to deal with simple roundabouts, even though it was not originally designed for that purpose. The conclusion from the study of Kenneth G. Courage has shown that it is possible to produce generally credible results in most cases from CORSIM link-node structure that approximates the configuration of a roundabout by a series of interconnected yield-controlled intersections. Modifications to CORSIM to enhance its roundabout modeling capacities are now under consideration. It appears that with some effort, the link-node structure of CORSIM should be adaptable as an excellent end-user performance evaluation tool to support the modeling of single-lane roundabouts.

**CAPCAL** (*Hagring 1997*) was developed by the Swedish National Road Administration (SNRA) about 20 years ago. A new version, CAPCAL2, was introduced in 1996. Both versions include programs for modeling both signalized and unsignalized intersections, as well as roundabouts. The inputs for roundabouts include the geometry of the roundabouts and traffic flow during a 1-hour period. The estimated performance measures include capacity, delays, queue lengths, vehicle operation costs, and emissions. The procedure used to assess roundabout performance involved six consecutive steps:

- (1) Estimation of the major flow.
- (2) Estimation of the critical gaps and the follow-up time.
- (3) Calculation the service times.
- (4) Allocation of the traffic flow to different entry lanes.
- (5) Estimation of the effects of lanes having limited storage.
- (6) Calculation of the performance measures.

## **7.6 RECOMMENDATIONS FOR FURTHER CONSIDERATION**

Recently, a study by Aimee Flannery (*Flannery and Datta 1998*) to test the SIDRA program in the US environment found that there is an agreement between SIDRA delay output and collected field data at low volume roundabouts, but the model underestimated results at higher volumes.

The company Ourston & Doctors uses the RODEL to design their roundabouts in many places in the US. However, there has been no study or information on the accuracy of this program to predict roundabout performance.

The 1997 price for SIDRA 5.02 was \$800, for ARCADY 3.0 was \$2,160, and RODEL was \$800. SIDRA and ARCADY are distributed by McTrans, Transportation Research Center, University of Florida, 512 Weil Hall, PO Box 116585, Gainesville FL 32611-6585; telephone 352 392-0378. RODEL can be ordered from RODEL Software Ltd., 11 Carlton Close, Cheadle, Stoke-on-Trent ST101LB, UK.

## **8.0 OTHER RELATED TOPICS**

### **8.1 PUBLIC PERCEPTION**

A major concern for roundabout implementation is not the roundabout itself, but the bad reputation of the traffic circle. People still do not make a clear distinction between modern roundabouts and traffic circles. When roundabouts were proposed, the public responses were most likely against them because they thought it was a traffic circle. Many proposals were declined.

An after-built roundabout public opinion study has been conducted by the state of Vermont in 1996 at Kirk Circle, Montpelier. Appendix A shows the survey results and conclusion. Even though the roundabout seems to be favored by the public overall, some complaints can be found and should be reviewed for better future implementation. Some complaints are that many drivers still do not know how to act at this roundabout. Many drivers do not know when to yield or to stop. Speed is still high in the roundabout.

To avoid public opposition, most successful proposals should start with educating people about the difference between roundabouts and traffic circles. Brochures, videotapes, and mass media can be used to inform the public during the development stage. The public will begin to understand, and opposition should be reduced gradually. This strategy has proved to be successful for improving public perception in Florida, Maryland, and Vermont.

### **8.2 FUNCTIONAL HIERARCHY**

Each functional class of road system is purposely designed to achieve its specific function. The movement function on a freeway or high type arterial is facilitated with uninterrupted, high-speed flow. As the vehicle nears its destination, the vehicle slows on a transition roadway or freeway ramp. The vehicle then moves on to a moderate speed arterial which serves as a distributor to carry the vehicle to a collector. The collector facility then carries the vehicle to a local access facility (*Layton 1996*). As a result, drivers' expectations on different facilities are different and should be kept in mind when a roundabout is being planned.

Roundabouts are designed to slow vehicles down while vehicles approach the intersections or transition roadways and continue through roundabouts with constant low speed. The study in Queensland, Australia (*Arndt 1997*), indicates the increase of accidents at the roundabouts where there were high differential speeds at intersected roads. This may be explained by the possibility that drivers on the higher speed road did not expect or were unwilling to slow their vehicles down while approaching roundabouts.

In summary, roundabouts should be appropriate at intersections of roadways with the similar functional classification. Another appropriate location in terms of functional class is the

transition between a freeway ramp and an arterial. However, this will be suitable only when speeds on the arterial street can be adequately controlled.

### **8.3 PUBLIC TRANSIT<sup>4</sup>**

The French recommend that locations for bus stops should be consistent with the needs of the users, and the access routes should be designed in such a way as to minimize pedestrian crossings of the various roundabout legs.

A bus stop can be situated:

- On an entrance leg (on the roadway), just upstream from the crosswalk, where traffic is moderate and the stopping time is short. This layout should not be used on two-lane entrances (a vehicle should not be allowed to pass a stopped bus);
- 20 m upstream from the crosswalk, in a pullout;
- On an exit lane, in a pullout just past the crosswalk.

On larger roundabouts, a bus pullout can be considered on the outside perimeter of the circulation roadway, on the condition that its placement won't create any predictable problems (e.g. pedestrians crossing the ring road).

---

<sup>4</sup> This section is based on a translation of the French guidelines by Michael Ronkin, ODOT.

## 9.0 REFERENCES

Akcelik, R., E. Chung, and M. Besley, "Roundabout Model Enhancement in SIDRA 4.1" ARRB Transport Research Working Paper (March 1995).

Akcelik, R., E. Chung, and M. Besley, "Performance of Roundabouts Under Heavy Demand Conditions," Road & Transport Research, Vol. 5, No. 2 (June 1996) pp. 36-50.

Akcelik, R., E. Chung, and M. Besley, "Getting Around Better," PC-Trans (Winter Quarter 1997) pp. 14-19.

Akcelik, R., E. Chung, and M. Besley, "Roundabouts: Capacity and Performance Analysis," ARRB Transport Research Ltd., Research Report No. 321 (March 1998).

Alphand, F., U. Noelle, and B. Guichet, "Evolution of Design Rules for Urban Roundabouts in France," Intersection Without Traffic Signals II, Springer-Verlag, Werner Brilon (Ed.) (1991) pp. 126-140.

Alphand, F., U. Noelle, and B. Guichet, "Roundabouts and Road Safety: State of the Art in France," Intersection Without Traffic Signals II, Springer-Verlag, Werner Brilon (Ed.) (1991) pp. 107-125.

American Association of State Highway and Transportation Officials (AASHTO), "A Policy on Geometric Design of Highways and Streets," 1990.

Armitage, D.J., and M. McDonald, "Roundabout Capacity" Traffic Engineering & Control (October 1974).

Arndt, Owen, "Draft Guideline for the Design of Roundabouts, Transport Technology Engineering and Traffic Design (1997).

Austroroad, "Guide to Traffic Engineering Practice, Part 6-Roundabouts" (1993).

Avent, A.M., and R.A. Taylor, "Roundabouts-Aspects of their Design and Operations," Queensland Division Technical Papers, Vol. 20, No. 17 (1979) pp. 1-10.

Bared, Joe G., William A. Prosser, and Carol Tan Esse, "State of the Art Design of Roundabouts," Transportation Research Board Annual Meeting January 1997, Washington, D.C. (January 1997).

Bergh, T., "Intersections Without Traffic Signals-Swedish Experience on Capacity and Traffic Safety," Intersection without Traffic Signals II, Springer-Verlag, Werner Brilon (Ed.) (1991) pp. 192-213.

- Brilon, Werner, "Traffic Engineering and the New German Highway Capacity Manual," *Transportation Research A*, Vol. 28A, No. 6 (1994) pp. 469-481.
- Brilon, Werner, and Birgit Stuwe, "Capacity and Safety of Roundabouts in West Germany," *Proceedings 15th ARRB Conference*, Vol. 15, Part 5 (1990) pp. 275-281.
- Brilon, Werner, and Birgit Stuwe, "Capacity and Design of Traffic Circles in Germany," *Transportation Research Record* 1398 (1993) pp.61-67.
- Brilon, Werner, Michael Grossmann, and Birgit Stuwe, "Toward a New German Guideline for Capacity of Unsignalized Intersections," *Transportation Research Record* 1320 (1991) pp. 168-174.
- Brilon, Werner, Ning Wu, and Lothar Bondzio, "Unsignalized Intersections in Germany: A State of the Art 1997," *Proceeding of the Third International Symposium on Intersections Without Traffic Signals* (1997) pp. 61-70.
- Brown, Mike, "The Design of Roundabouts," *Transport Research Laboratory* (1995).
- Brude, Ulf, and Jorgen Larsson, "The Safety of Cyclists at Roundabouts- a Comparison Between Swedish, Danish and Dutch Results," *Nordic Road & Transport Research*, No.1 (1997) pp.23-25.
- Cassidy, Michael J., Samer M. Madanat, Mu-Han Wang, and Fan Yang, "Unsignalized Intersection Capacity and Level of Service: Revisiting Critical Gap," *Transportation Research Record* 1484 (1995) pp. 16-23.
- Cedersund, H.A., "Traffic Safety at Roundabouts," *Intersection Without Traffic Signals I*, Springer-Verlag, Werner Brilon (Ed.) (1988) pp. 305-318.
- Center for Research and Contract Standardization in Civil and Traffic Engineering-The Netherlands (CROW), "Sign Up for the Bike: Design Manual for a Cycle-Friendly Infrastructure," (1994).
- CETRA, "Amenagements Des Carrefours Interurbains, Chapitre a, les Carrefours a Sens Giratoire." (1996).
- Chang, Stanley H., "Overcoming Unbalanced Flow Problems at a Roundabout by Use of Part-Time Metering Signals," *Master's Thesis of Monash University* (January 1994).
- Chin, H.C., "SIMRO: a Model to Simulate Traffic at Roundabouts," *Traffic Engineering & Controls*.
- Chung, Edward, "Comparison of Roundabout Capacity and Delay Estimates from Analytical and Simulation Models" *Proceedings 16th ARRB Conference*, Vol. 16, Part 5 (1992).
- Courage, Kenneth G., "Roundabout Modeling in CORSIM," *The Third International Symposium on Intersections Without Traffic Signals*, July 21-23, 1997, Portland, Oregon, USA.



Department of Transport, "Determination of Size of Roundabouts and Major/Minor Junctions," Great Britain, Departmental Advice Note TA 23/81 (1981).

Department of Transport, "The Geometric Design of Roundabouts," Great Britain, Departmental Standard TD 16/84 (Reprinted 1988).

Fisk, C.S., "Traffic Performance Analysis at Roundabouts," Transportation Research-B, Vol. 25B, No. 2/3 (1991) pp. 89-102.

Flannery, Aimee, and Tapan K. Datta, "Modern Roundabouts and Traffic Crash Experience in United States," Transportation Research Record 1553 (1996) pp. 103-109.

Flannery, Aimee, and Tapan K. Datta, "Operational Analysis and Performance of American Roundabouts," 1996 ITE Compendium of Technical Papers (1996).

Flannery, Aimee, and Tapan K. Datta, "Operational Performance Measures of American Roundabouts," Transportation Research Board Annual Meeting January 1997, Washington, D.C. (January 1997).

Flannery, Aimee, Lily Elefteriadou, Paul Koza and John McFadden, "Safety, Delay and Capacity of Single Lane Roundabouts in the United States," 77<sup>th</sup> Annual Transportation Research Board Meeting, January 11-15, 1998.

Florida Department of Transportation, "Florida Roundabout Guide," (1996).

Gambard, J.M., "Safety and Design of Unsignalized Intersections in France," Intersections Without Traffic Signals I, Springer-Verlag, Werner Brilon (Ed.) (1988) pp. 48-61.

Guichet, Bernard, "Roundabouts in France: Development, Safety, Design, and Capacity," Proceeding of the Third International Symposium on Intersections Without Traffic Signals (1997) pp. 100-105.

Guichet, Bernard, "Guide Carrefour Urbain, Chapitre VII, Roundabouts." (March 1995).

Hagring, Ola, "The Use of the Cowan M3 Distribution for Modeling Roundabout Flow," Traffic Engineering & Control (May 1996) pp.328-332.

Hagring, Ola, "A new Swedish Roundabout Capacity Model," Proceeding of the Third International Symposium on Intersections Without Traffic Signals (1997) pp.109-114.

Hakkert, A.S., D. Mahalel, and S.A. Asante, "A Comparative Study of Roundabout Capacity Procedures," Intersection without Traffic Signals I, Springer-Verlag, Werner Brilon (Ed.) (1988) pp. 93-106.

Hoglund, Paul G., "Case Study. Performance Effects of Changing a Traffic Signal Intersection to Roundabout," Intersection without Traffic Signals I, Springer-Verlag, Werner Brilon (Ed.) (1988) pp. 141-158.

Horman, C.B., "Design and Analysis of Roundabouts," Proceedings 7th ARRB Conference, Vol. 7, Part 4 (1974) pp. 58-82.

Hughes, B.P., "So You Think You Understand Gap Acceptance!," Australian Road Research Board, 19(3) (1989) pp. 195-204.

ITE Technical Council Committee 5B-17, "Use of Roundabouts," ITE Journal (Feb. 1992) pp. 42-45.

Kimber, R.M., "The Traffic Capacity of Roundabouts," Transport and Road Research Laboratory Report 942 (1980).

Kimber, R.M., "Gap-Acceptance and Empiricism in Capacity Prediction," Transportation Science, Vol. 23, No. 2 (1989).

Kimber, R.M., "The Design of Unsignalized Intersections in the UK," Intersection without Traffic Signals I, Springer-Verlag, Werner Brilon (Ed.) (1988) pp. 20-34.

Kimber, R.M., and Erica M. Hollis, "Traffic Queues and Delays at Road Junctions," Transport and Road Research Laboratory Report 909 (1979).

Kyte, Michael, "Capacity and Level of Service of Unsignalized Intersections: New Practices in the United States," Proceeding of the Third International Symposium on Intersections Without Traffic Signals (1997) pp. 171-177.

Lalani, N., "The Impact on Accidents of the Introduction of Mini, Small and Large Roundabouts at Major/Minor Priority Junctions," Traffic Engineering & Control (December 1975) pp. 560-561.

Layfield, R.E., and G. Maycock, "Pedal-Cyclists at Roundabouts," Traffic Engineering & Control (June 1986) pp. 343-349.

Layton, Robert D., "Functional Integrity of the Highway System," Oregon Department of Transportation (1996).

List, George, Siew Leong, Yursi Embong, Azizan Naim, and Jennifer Conley, "Case Study Investigation of Traffic Circle Capacity," Transportation Research Record 1457 (1994) pp. 118-126.

Maryland Department of Transportation, "Roundabout Design Guideline," (1995).

Maycock, G., and R.D. Hall, "Accidents at 4-arm Roundabouts," TRRL Laboratory Report 1120 (1984).

McDonald, M., and D.J. Armitage, "The Capacity of Roundabouts," Traffic Engineering & Control, Vol. 19 (October 1978) pp. 447-450.

Myers, Edward J., "Modern Roundabouts for Maryland," ITE Journal (Oct. 1994) pp. 18-22.

National Association of Australian State Road Authorities (NAASRA), "Roundabout: a Design Guide," (1986).

Oregon Department of Transportation, "Oregon Bicycle and Pedestrian Plan," Bicycle and Pedestrian Program (1995).

Ourston, Leif; and Joe G. Bared, "Roundabouts: A Direct Way to Safer Highways," Public Roads (Autumn 1995) pp. 41-49.

Ourston, Leif, and Peter Doctors, "Roundabout Design Guidelines," Ourston & Doctors Modern Roundabout Interchanges (1995).

Ourston, Leif, and Gregory A. Hall, "Modern Roundabout Interchanges Come to America," 1996 ITE Compendium of Technical Papers (1996).

Pearce, C.E.M., "A Probabilistic Model for the Behavior of Traffic at Roundabout," Transportation Research B, Vol. 21B, No. 3 (1987) pp. 207-216.

Persula, Matti, Ola Hagrind, and Jarkko Niittymaki, "Simulation and Capacity Calculation of Intersections Without Traffic Signals- A Discussion and a Roundabout Case Study," The Third International Symposium on Intersections Without Traffic Signals, July 21-23, 1997, Portland, Oregon, USA.

Polus, Abishai, and Sitvanit Shmueli, "Analysis and Evaluation of the Capacity of Roundabouts," Transportation Research Board Annual Meeting January 1997, Washington, D.C. (January 1997).

Redington, T., "The Modern Roundabout Arrives in Vermont," AASHTO Quarterly Magazine, Vol. 75, No. 1 (1995) pp. 11-12.

Redington, Tony, "Montpelier's Modern Roundabout at Keck Circle Neighborhood Opinion Survey: January 1997." <http://www-uftrc.ce.ufl.edu/wwwround/montpeli.htm>.

Rahman, Mountasser A., "Design Criteria for Roundabouts," 1995 ITE Compendium of Technical Papers (1995).

Schoon, C., and J. van Minnen, "The Safety of Roundabouts in The Netherlands," Traffic Engineering and Control, Vol. 35, No. 3 (1994) pp. 142-148.

Seim, Kjell, "Use, Design and Safety of Small Roundabouts in Norway," Intersection without Traffic Signals II, Springer-Verlag, Werner Brilon (Ed.) (1991) pp. 270-281.

Semmens, Marie C, "Arcady2: An Enhanced Program to Model Capacities, Queues and Delays at Roundabouts," Transport and Road Research Laboratory Research Report 35 (1985).

Simon, Michael J., "Roundabouts in Switzerland," Intersection without Traffic Signals II, Springer-Verlag, Werner Brilon (Ed.) (1991) pp. 41-52.

- Smith, Mark J., "Improved Signing for Traffic Circles," New Jersey Department of Transportation, FHWA/NJ-91-003 91-003-7350 (1990).
- Stuwe, Birgit, "Capacity and Safety of Roundabouts-German Results," Intersection without Traffic Signals II, Springer-Verlag, Werner Brilon (Ed.) (1991) pp. 1-12.
- Tan, Jian-an, "A Microscopic Simulation Model of Roundabout Entry Operations," Intersection without Traffic Signals I, Springer-Verlag, Werner Brilon (Ed.) (1988) pp. 159-176.
- Tan, Jian-an, "Estimation of Traffic Queues and Delays at Roundabout Entries," Proceeding of the Third International Symposium on Intersections Without Traffic Signals (1997) pp. 248-260.
- Taylor, Marie C., "UK Techniques for the Prediction of Capacities, Queues, and Delays at Intersections Without Traffic Signals," Intersection without Traffic Signals I, Springer-Verlag, Werner Brilon (Ed.) (1991) pp. 274-288.
- Technical Research Centre of Finland (VTT), "Traffic Effects of a Roundabout," Nordic Road & Transport Research, No. 1 (1993) pp. 9-11.
- Todd, Kenneth, "A History of Roundabouts in Britain," Transportation Quarterly, Vol. 45, No. 1 (1991), pp. 143-155.
- Todd, Kenneth, "A History of Roundabouts in the United States and France," Transportation Quarterly, Vol. 42, No. 4 (1988), pp. 599-623.
- Troutbeck, R.J., "Capacity and Delays at Roundabouts-A Literature Review," Australian Road Research Board, 14(4) (1984) pp. 205-216.
- Troutbeck, R.J., "Does Gap Acceptance Theory Adequately Predict the Capacity of a Roundabout," Proceedings 12th ARRB Conference, Vol. 12, Part 4 (1985) pp. 62-75.
- Troutbeck, R.J., "Evaluating the Performance of a Roundabout," Australian Road Research Report SR 45 (1989).
- Troutbeck, R.J., "Traffic Interactions at Roundabouts," Proceedings 15th ARRB Conference, Vol. 15, Part 5 (1990).
- Troutbeck, R.J., "Current and Future Australian Practices for the Design of Unsignalized Intersections," Intersections Without Traffic Signals I, Springer-Verlag, Werner Brilon (Ed.) (1988) pp. 1-19.
- Troutbeck, R.J., "Recent Australian Unsignalised Intersection Research and Practices," Intersection without Traffic Signals II, Springer-Verlag, Werner Brilon (Ed.) (1991) pp. 238-257.
- Troutbeck, R.J., "Changes to the analysis and design of Roundabouts initiated in the Austroads Guide" Proceedings 16th ARRB Conference, Vol. 16, Part 5 (1992).

Troutbeck, R.J., "Capacity and Design of Traffic Circles in Australia," *Transportation Research Record* 1398 (1993) pp. 68-74.

Troutbeck, R.J., "Effect of Heavy Vehicles at Australian Traffic Circles and Unsignalized Intersections," *Transportation Research Record* 1398 (1993) pp. 54-60.

Troutbeck, R.J., "Country Report-Australia," *Proceeding of the Third International Symposium on Intersections Without Traffic Signals* (1997) pp. 291-293.

Tudge, R.T., "Accidents at Roundabouts in New South Wales," *Proceedings 15th ARRB Conference*, Vol. 15, Part 5 (1990).

van Arem, Bart, "Capacities and Delays at Roundabouts in The Netherlands," *Proceedings of Seminar H held at the PTRC Transport, Highways and Planning Summer Annual Meeting*, University of Manchester Institute of Science and Technology, England, from 14-18 September 1992 (1992) pp. 257-267.

van Minnen, J., "Roundabouts," *Institute for Road Safety Research SWOV*, The Netherlands (1986).

Wallwork, Michael J., "Roundabouts," *Genesis Group, Inc.* (1995).

Worthington, J.C., "Roundabout Design: A Comparison of Practice in the UK and France," *Proceedings of Seminar H held at the PTRC Transport, Highways and Planning Summer Annual Meeting*, University of Manchester Institute of Science and Technology, England, from 14-18 September 1992 (1992) pp. 269-279



## **APPENDIX A**

### **MONTPELIER'S MODERN ROUNDABOUT AT KECK CIRCLE NEIGHBORHOOD OPINION SURVEY: JANUARY 1997**





## **EXECUTIVE SUMMARY**

This report contains the results of a public opinion survey of 111 persons who live and work near the first modern roundabout in the northeast, Keck Circle, at Montpelier, Vermont, about five blocks from the State Capitol.

Conducted during the summer and early fall of 1996, it followed by about a year the August 16, 1995 project completion at Main and Spring Streets. The five-question survey included two open response questions so each respondent could contribute "likes," "dislikes," and what they "miss about the old intersection." Comments totaled 214 from the respondents, and every response is contained in this report.

All told, 85.5% respondents had a favorable or neutral opinion of the roundabout, 14.4% held an unfavorable opinion. By a four-to-one margin, 64-16, favorable opinions outnumbered unfavorable responses. By a 30-7 margin, "very favorable" responses outnumbered "very unfavorable" responses.

About a third of respondents were interviewed by telephone, a third door-to-door, and the final third represented surveys filled out at nearby workplaces--mostly the Main Street Middle School staff, home businesses, and professional offices. The survey intent was to obtain the opinions of those most familiar in their daily comings and goings with the intersection, both before and after it became a roundabout. All told 80.2% of respondents reported they had walked through the roundabout, 93.7% had driven through the roundabout and 17.1% had bicycled through it.

Positive comments stressed the smooth flow of traffic, the increased ease of accessing businesses adjacent to the intersection, the attractiveness of the roundabout and its safety. Dislikes centered on driver behavior--failure to yield, drivers not following the rules, and need for education of drivers. Some suggested there were more important priorities for the expenditure than a roundabout, and another frequent comment was the need to improve the appearance of the mountable apron both for operational as well as aesthetic reasons.

Half the comments on what was missed about the old intersection amounted to simply "nothing" or an equivalent response. Specific comments included: (1) the loss of two former pedestrian crossings; and (2) the sense the old intersection was safer for cars and pedestrians.

## **BACKGROUND--THE MODERN ROUNDABOUT**

The first modern roundabout in the northeast began operation the evening of August 16, 1995 at Spring and Main Streets in Montpelier. The site, about five blocks from the Vermont State Capitol building, is surrounded by residential, institutional, professional office and lodging uses.

The modern roundabout, which dates from 1963 in England, finally arrived in the United States in 1990 in a major Las Vegas residential subdivision. When the first snow country roundabouts in the nation were built in 1995-- the Montpelier roundabout and two at the in I 70 exit in Vail, Colorado--roundabouts then numbered about a dozen nationally. Today, about a year later, the number jumped to 28. In Vermont, four new roundabouts are entering or in final design with

construction likely in 1997 and 1998. In the November 1996 election, Avon, Colorado, the next exit after Vail, approved a \$3.5 million, 20-year bond issue for five roundabouts from the I 70 interchange to the Beaver Creek Mountain ski resort. The roundabout community anticipates that roundabouts will be built in the United States annually by the hundreds in a year or so and by the thousands annually early in the next century, duplicating the trends first in Britain and Australia during the 1970s and 1980s and now being repeated throughout western Europe. For example, the Paris newspaper Le Monde (October 3, 1996) reported France with over 12,000 roundabouts. Most have been built since the mid-1970s.

A roundabout has three major characteristics compared to its predecessors, traffic circles and rotaries. First, the roundabout gives vehicles in the circular travel way the right-of-way. This change on a national basis in England in 1963 marked the roundabout era beginning. Second, roundabouts are small, generally from 70 to 160 feet in diameter compared to 300 to 400 feet and more for traffic circles and rotaries. Third, roundabouts have a entry "splitter" island that slows down or constrains speed just before entry, duplicating in a way the curvature the driver will experience within the roundabout itself.

In technical and non-technical performance of the roundabout as an intersection control device far surpasses traditional stop sign and yield techniques, and the traffic signal. Data reveals traffic signals actually result in higher accident and injury rates over stop signs and yield controls (1). One Netherlands study of 181 new modern roundabout installations before and after performance shows roundabouts cut car occupant injuries by 95%, pedestrian injuries 89%, and bicycle injuries 30% (2). When injuries do occur at roundabouts they tend to be less severe than those at traffic lights and signed intersections. The roundabout accident performance in the study was uniformly superior in urban, suburban and rural locations. The most conservative estimate from reviewing data from several nations concludes roundabouts cut collisions by 50 percent (3, 4).

Roundabouts self-police vehicle speeds and traffic calm about 100 yards in each direction, unlike signal systems require no electricity, cost less, use less land, enable U-turns, save energy, reduce pollution, and introduce beauty to intersections. Roundabouts feature approximately half the collisions and a third of the injuries of signalized or unsignalized intersections. In terms of peak hour, delay per car at the Montpelier roundabout is 2.7 seconds compared to 6.3 seconds for the old signed intersection (5). At moderately high volume four-way intersections, roundabouts cut average delay of signalized intersections by two thirds.

## **KECK CIRCLE: HISTORY**

In 1991 the Towne Hill neighborhood held informal discussions about a basic approach to improving their 0.8 mile street, currently without sidewalks. Residents expressed concerns about frequent accidents, injuries to young people, increasing speeds, and the increased traffic from the upcoming connection of Montpelier's end of Towne Hill Road with US 2 following reconstruction of the dirt portion in neighboring East Montpelier (completed in 1993).

The neighborhood expressed a desire for an approach that promised a narrow, slow, pedestrian and bicycle friendly road--not the wider faster smoother highway being built next door in East Montpelier connecting the neighborhood to US 2. The neighborhood decision came at an early meeting in 1992 attended by about 60 persons. But one problem remained, what techniques could be used to traffic calm--a term common in Europe but brand new to Vermont in 1991?

Montpelier is in the Green Mountains snowbelt with about a hundred inches of snow and plenty of freeze/thaw cycles. What traffic calming techniques could slow down traffic to the 20-25 mph desired by the Towne Hill citizens? What was appropriate from the European experience--speed tables? chokers? chicanes? roundabouts? Clearly speed humps and bumps, the only techniques most were familiar with, were not particularly popular choices.

A few months later the Vermont Agency of Transportation and Vermont Trails and Greenways Council sponsored bicycle and pedestrian training that included a day on "traffic calming" techniques. A Florida State Department of Transportation two-person team taught the sessions. On team member, Michael J. Wallwork, P.E., a noted former district engineer from Melbourne, Australia and leading proponent of roundabouts in the United States, used Towne Hill Road as a case study for the use of traffic calming techniques, including roundabouts. Wallwork along with a California engineer, Lief Ourston, of Santa Barbara, are the Johnny Appleseeds of roundabouts in America.

As a result of this presentation, the Towne Hill citizens and the City of Montpelier became very interested in roundabouts as a possible traffic calming device for any Towne Hill reconstruction and as a remedy for other poorly functioning intersections in the City. Consequently, the City Council in the fall of 1992 authorized a citizens committee, the Montpelier Roundabout Demonstration Committee, to begin exploring the possibility of locating a demonstration roundabout in Montpelier. Peter Meyer, co-chair of the Towne Hill Committee and Tony Redington, a state employee with interest in traffic calming, were co-chairs. Other members of the Committee were, initially, Police Chief Doug Hoyt, Public Works Director Steve Gray, City Planning Director Joseph Zehnder who was succeeded by Valerie Capels, Planning Commissioner Alan Lendway, and citizens Andy Keck, and Dona Bate. Keck, a Montpelier activist and businessman, was a key supporter throughout the project. He died just after the roundabout construction began, and the City Council named the roundabout Keck Circle in his honor later in 1995. Wallwork essentially volunteered technical assistance to the City of Montpelier throughout most of the three years of the project development.

A major report recommending a demonstration was completed and delivered by the Committee to the City Council in January 1993. The Council authorized the Committee to proceed to choose a site and undertake a feasibility study. The Committee considered several intersections for a demonstration and initially settled on State Street and Bailey Avenue, wanting to choose a location where a traffic signal could be replaced. A simulation at the intersection with large trucks, buses, and emergency vehicles was held in summer 1993. This included examining the design requirements of Montpelier's fire and emergency vehicles, requirements incorporated in the Keck Circle final design.

Public meetings on a State/Bailey demonstration uncovered public concerns, particularly over a roundabout without a walk signal light in place of the signal with the walk phase. Further, the intersection as is cannot, as a demonstration site, fully accommodate buses--and tour buses and school busses are a staple of the Capitol building located a few hundred feet down State Street. Further discussion led to consideration Keck Circle, a Y intersection with a triangular island containing a tree, that still graces the center island today. One block from Middle School with an accident rate about triple that of an average Y intersection, the intersection contained a single crossing exposing pedestrians to 100 feet of roadway carrying traffic. The roundabout cuts

pedestrian exposure to the traffic travelway by 60% and permits the pedestrian to cross one lane at a time.

The City Council approved design funding in early 1994 and a construction start was targeted for summer 1994. A number of public meetings were held during the engineering consultant selection and preliminary planning stages. Several firms bid on the design, and Pinkham Engineering of Burlington, low bidder, was selected. Pinkham had provided early assistance and recommended a permanent installation for Keck Circle because it was most cost efficient. The Committee and City staff had learned a great deal during 1992-1993 about roundabouts and were increasingly confident of the practicality of the roundabout and the high likelihood of success. In late spring 1994, the Committee learned the estimated costs, about \$50,000 had been assumed, was about \$100,000 too low. The sidewalk (900 feet) and landscaping alone cost about \$50,000 (eventual total roundabout costs, about \$162,000).

The Committee took a step back to look at alternatives. The Committee after considerable discussion decided to attempt to do some fund raising, plus further the information and education throughout the community on the project. A state enhancements grant application for \$60,000 was prepared and submitted for the sidewalks and landscaping. A small amount of funds were raised and all citizens were given a chance to participate through small contributions. In the budget cycle of the City Council in December 1994 and early 1995, the Council following input from the Public Works Department, added to funds from the 1995 and 1996 Capital Budget to those already reserved for the roundabout. The Budget was passed at Town Meeting in March 1995, and the project moved quickly to construction in mid-June 1995.

As part of the startup, the Committee prepared a brochure on how to walk, bike, and drive through a roundabout. News releases and Public Service Announcements were prepared and provided the local media. A lot of construction occurred in Montpelier in the summer of 1995 including practically all of Main Street from the roundabout to the Winooski River. There was considerable negative public reaction at the time of construction of the roundabout, including negative commentary from local morning radio personalities. The experience where other roundabouts were introduced (Lisbon, Maryland and Santa Barbara, California, for examples) was also initially negative from the media and some of the public followed by support. The Vail press, for example, opposed roundabout construction but are now staunch supporters. As the survey here shows, Montpelier's roundabout is now very popular.

## **KECK CIRCLE: FACTS AND FIGURES**

DATE OPENED--August 16, 1995 at 7:45 p.m. (first users, two young bicyclists).

NORTHEAST FIRST--Keck Circle is the first modern roundabout built in the northeast (north of Maryland and east of the Mississippi). Also, Keck Circle and two roundabouts in Vail, Colorado, were the first built in U.S. snowbelt areas. Keck Circle is reportedly the first built in a U.S. urban setting that is used by substantial numbers of pedestrians.

TYPE OF INTERSECTION--A "Y" intersection composed of north to south Main Street intersecting with Spring Street to the west. State route VT 12 travels on Spring Street and the south leg of Main Street.

**ANNUAL AVERAGE DAILY TRAFFIC (AADT) VOLUME**--Approximately 11,000 daily; approximately 7,300 AADT each leg. During a typical weekday, about 40 heavy trucks (five axle-or-more) have been counted, about one every 20 minutes.

**ADJACENT LAND USES**--land uses within 500 feet include Main Street Middle School (about 400 students), single family and apartment housing, a considerable number of professional and service business offices, a Masonic Temple, historic buildings, the Inn at Montpelier, and a senior housing complex. The roundabout is two blocks from the center of the community.

**THE KECK CIRCLE NAME**--Named in fall 1995 by the Montpelier City Council for a citizen activist, Andy Keck of Montpelier, a member of the Montpelier Roundabout Committee, who died shortly after roundabout construction began.

**ACCIDENTS**--For the period 1991 to May 1996, 1.4 accidents per year (all), 0.7 injury accidents per year. Accidents August 16, 1996 through January 1, 1997 (16 months): one, a pedestrian who received bumps and bruises when hit on a roundabout crosswalk early in the afternoon.

**PEDESTRIAN TRAFFIC**--Pedestrian counts vary, but intersection counts show volumes up to 260 for the a.m. period on school days (p.m. counts are similar).

**TRUCK ACCOMMODATION**--accommodates all trucks including interstate tractor trailers.

**STRAIGHT "A" "LEVEL OF SERVICE" (LOS)**--Before peak hour delay (legs A, B, and C) was 6.3 seconds for the average vehicle, LOS B overall. All legs and the intersection overall were LOS A, 2.7 average, for the roundabout.

**RADIUS OF KECK CIRCLE**--Not a perfect circle, the Keck Circle radius (to the outside curb) ranges from 52.7 feet to 54.2 feet.

## **SURVEY METHODOLOGY**

The Committee considered a public survey as important for two reasons: (1) to determine the public opinion approximately one year after the opening of the roundabout; and (2) to determine the likes and dislikes of the roundabout that could assist the Public Works Department and the City Council on steps to add some finishing touches to improve Keck Circle.

Before the survey, it was known that many people were concerned about the appearance of the mountable ramp or apron that serves to accommodate the larger tractor trailer trucks. This apron was expanded by about 10 feet in width and changed from simple concrete (whitish) to asphalt (black) as part of the only significant design adjustment identified after the start of construction. Further, there were concerns about drivers failing to yield sometimes to people in the circular travelway. The survey was designed for those who, both before and after construction, lived in neighborhoods nearby Keck Circle or worked within a block or two of the intersection. The area surveyed was roughly from Montpelier Inn north to the end of Main Street, the Meadow, Spring Street, the Franklins, lower Liberty and Loomis Streets. Other streets with respondents were

Cross, Jay, Harrison, St. Paul, Brown and North Street. Workers surveyed included those in home-based concerns, the Gary Home, Pioneer Apartments (Montpelier Housing Authority), Main Street Middle School, and professional offices, mostly on Main and Spring Streets.

There were three ways in which questionnaire responses were obtained. About one-third of the respondents were interviewed by telephone, a second third of the completed questionnaires came from leaving questionnaires at work places for later pick up, and the last third were obtained through door-to-door interviews. Telephone and those left and later picked up provided slightly more favorable results versus the door-to-door interviews. However, all three were strongly favorable to the roundabout.

The sample was carefully chosen to include primarily those who lived and worked nearby and used the roundabout on a daily basis, a group sure to use the roundabout almost daily and also familiar with the pre-roundabout intersection. Of the three interviews rejected, one was a person who in answer to the question "what do you miss about the old intersection, " who replied, "I did not live here then."

## **SUMMARY OF RESPONSES**

Of the total 111 interviewed, 95 or 85.5% were "Favorable" or "Neutral" toward the roundabout, and 14.4% "Unfavorable." By a four-to-one margin, 64-16, "Favorable" outnumbered "Unfavorable" responses. "Very Favorable," again, outnumbered "Very Unfavorable," 30 to 7.

In terms of those who drove, walked, or bicycled through the roundabout, 93.7% had driven, 80.2% had walked, and 17.1% had bicycled through the roundabout. These figures help to confirm the fact that the respondents were familiar with the roundabout. One surprise was that tabulation of those who walked versus non-walkers, bicyclists versus non-bicyclists, and drivers only (non-walkers, non-bicyclists) showing practically no variation at all among three groups in terms of their overall Favorable versus Unfavorable opinions. The figures for nearby neighborhood residences were as follows:

- 69.4% (77) resident of nearby neighborhood
- 8.1% (9) Meadow
- 4.5% (5) Cross Street/Franklins
- 16.2% (18) Liberty Street
- 21.6% (24) Loomis Street
- 18.9% (21) Main and Spring Streets

## **QUESTIONNAIRE DETAILS**

PLEASE ANSWER THE FOLLOWING QUESTIONS ABOUT THE ROUNDABOUT AT KECK CIRCLE, SPRING/MAIN STREETS. WE WOULD LIKE YOUR OPINIONS ON HOW THE ROUNDABOUT OPERATES, CONCERNS ABOUT COSTS AND OTHER ISSUES CAN BE PLACED IN THE COMMENTS SECTION.

1. WOULD YOU SAY YOUR OPINION OF THE KECK CIRCLE ROUNDABOUT IS:  
--27.0% (30)--VERY FAVORABLE

- 30.6% (34)--FAVORABLE
- 27.9% (31)--NEUTRAL
- 8.1% (9)--UNFAVORABLE
- 6.3% (7)--VERY UNFAVORABLE
- 0.0% (0)—OTHER

2. IS THERE ANYTHING YOU LIKE OR DISLIKE ABOUT THE ROUNDABOUT?

3. PLEASE CHECK ALL THAT APPLY: I HAVE:

- 93.7% (104)--DRIVEN THROUGH THE ROUNDABOUT
- 80.2% (89)--WALKED THROUGH THE ROUNDABOUT
- 17.1% (19)--BICYCLED THROUGH THE ROUNDABOUT
- 0.9% (1)--OTHER (PLEASE EXPLAIN)

4. WHAT DO YOU MISS ABOUT THE OLD INTERSECTION

5. PLEASE CHECK RESIDENCE AREA AND/OR EMPLOYMENT IN AREA:

- 69.4% (77) RESIDENT OF NEARBY NEIGHBORHOOD
- 8.1% (9) MEADOW
- 4.5% (5) CROSS STREET/FRANKLINS
- 16.2% (18) LIBERTY
- 21.6% (24) LOOMIS
- 18.9% (21) MAIN/SPRING
- 44.5% (49) WORK IN AREA
- 82.7% (91) FROM MONTPELIER
- 17.2% (19) FROM ANOTHER

By town of residence, the respondents were (sample 110): 82.7% (91) Montpelier and 17.2% (19) Another Town. Workers in the area totaled 44.5% (49).

## TABULATION OF COMMENTS

Responses to the three comment questions totaled 214, about two per respondent. "Likes" totaled 65 responses (58.6% of respondents), "Dislikes" 56 (50.5% of respondents), and "What Do You Miss About the Old Intersection" 82 (73.9% of respondents). A category of "Miscellaneous" totaled 11 and represented comments respondents clearly wanted relayed to the City.

Likes:

The responses, "flow of traffic" and "keeps traffic moving" typify the most frequent comments regarding smooth and better traffic movement. There were several comments specifying easier access to businesses at the Circle: "it's easier to get in and out of our parking lot--we only have to look one way," said one respondent. Not having to stop, the ease of entry into the intersection, and no stop signs were among other traffic comments. Several referred to improved conditions for pedestrians. "Great for pedestrians! Before it was very dangerous," was one comment. Some said they did not like the roundabout at first but do now, like the appearance, and revised their previous route because the roundabout and associated intersections were much safer than the intersections they were using before.

#### Dislikes:

The bulk of the dislikes centered on comments on driver behavior--cars failing to yield, follow the rules, and failure to use directionals. Almost half the "Dislikes" comments centered on driver behavior issues. Failure of cars to yield north or southbound Main Street were mentioned several times. One young person commented: "kids know how to drive the roundabout--older people don't know how."

The appearance of the roundabout received particular notice, with negative opinions expressed about the appearance of the mountable ramp or apron, with strong suggestions that this aesthetic and operational concern be addressed. "Center plate," "Visually poor, ugly, too much blacktop," "appearance needs improving (the collar area), even green paint would help as a driving visual clue and color enhancement," were comments in this area.

Some considered the roundabout as unsafe for cars and pedestrians. One older citizen expressed a sense of fear while walking at the roundabout that a car would come over the curb. Another expressed unwillingness to let her daughter walk through the roundabout because of belief it is unsafe for pedestrians. "How it handles pedestrian traffic--think it is more dangerous," said one.

The cost of the roundabout and the higher priorities for expenditure of funds comprised a significant number of "Dislikes." "Am convinced money could have been spent more wisely on failing infrastructure elsewhere," said one respondent.

#### What Do You Miss About the Old Intersection?

There were about 45 negative or neutral comments about the old intersection and 35 positive comments about the past configuration.

#### Negative or Neutral Comments on the Old Intersection (Details):

The most frequent comment response to any question was to the "what do you miss" and that comment was "nothing," offered by 24 respondents (21.6% of all respondents). And another 16 respondents gave essentially the same response ranging from "hardly anything," to "I don't think I miss a thing" and "can't say I miss it at all."

A scattering of other comments included "lost tourists trying to turn around," "frustration," "watching semi's try to get through," and "insecurity of trying to dash across traffic, sitting and waiting for traffic, and speeders passing Main Street School."

#### Positive Comments about the Old Intersection (Details):

Positive comments varied. They included references to the trees taken down in front of Masonic Temple, the loss of crosswalks at Brown Street and in front of the Gary Home, the thought that it was safer and less confusing, that drivers knew better what to do, and "continuity of Main Street itself as a street rather than an intersection." Other comments referred to the cost of the new intersection, convenience, the simplicity, etc.

#### Miscellaneous Comments (Details):

There were 11 miscellaneous comments. One respondent said "we could use some of these [in Burlington]," while another said "no we do not want/need a roundabout in Morrisville." The spouse of one respondent was involved in a fender bender in the roundabout, another blew a tire



on the roundabout curb--neither respondent, incidentally, held an unfavorable opinion of the roundabout. Concern was expressed about other intersections, Elm and Spring Streets, School and Main Streets (even with the new bulbouts), and the pedestrian crossing on Main Street at Langdon Street.

#### LIKES

Traffic mover.

Traffic flows, green in middle.

Flow of traffic.

I love the way it flows!

Really keeps traffic moving.

Seems to keep traffic moving.

Traffic flows better than at the old intersection.

Things really move along so much better.

It's easier to get out of our parking lot--we only have to look one way.

I love it--I never have problems getting out of our drive way at night--I used to have to wait for the backed up traffic.

It has done away with cars from Spring Street not yielding to southbound Main Street traffic.

Works really good...it's cute.

It works--gets traffic through faster and safer than used to be the case.

Smooth and easy driving.

Just as good as before.

I like it a little better because it slows people down.

Does move traffic better...better for pedestrian traffic.

It works better as far as traffic is concerned.

Keeps traffic moving.

Keeps traffic moving. Small scale--seems to be less crazy than roundabouts in Massachusetts or Europe--one lane not two.

Ease of moving into traffic--no wait. East of crossing street for pedestrians.

Traffic is a little better--I was negative at first.

Easier access, less waiting.

Cars slow down in what was a bad intersection--I had fender bender (before) from car down Main Street--can't have one now!

Slow traffic.

Slows down traffic on Main Street, makes it easier from Spring Street.

Slows traffic down--was hard for pedestrians.

It works smoother than previous.

Seems a lot more safe than the old intersection. I enjoy it and think it prevents accidents.

Better for pedestrians than cars...cars do go slower.

Great for pedestrians! Before it was very dangerous.

Tends to speed movement of traffic without increasing actual speed.

Good traffic flow, slower and safer Improved pedestrian crossing.

I think it helps the traffic move through quicker.

Smoother traveling.

Coming from Elm Street easier.

Now drive Elm Street purposely to safe Spring/Main connection [to Franklins/Cross Street neighborhood] and avoid dangerous School to Main Street intersection

Attractive, once your in it, it seems to be OK.  
Like central island.  
I feel the roundabout has been a success. Traffic flow is good and pedestrian crossing a big plus.  
Lot easier to get through the intersection.  
Does what it is designed to do, functioning correctly.  
Easier to cross the street as a pedestrian, particularly for kids at Middle School.  
Works out fine.  
Works fine.  
No problems, easier walking.  
Better aesthetics.  
Hard at first...OK now.  
Works as good now as it did before.  
Easy, friendly, smooth traveling in and out.  
Seems to work.  
Helps traffic.  
Different. Good place for a fountain.  
Makes intersection a lot safer.  
Purposely use that intersection now, used to avoid it.  
Traffic slower when walking through it, traffic keeps on going.  
Working better than I expected.  
Living right here, people slow down more...and there is less noise now.  
I was prepared to hate it, but I do like it and find it much safer when I walk to work.  
Not waiting at a stop sign.  
It seems to work fine if people would yield properly.  
Not stopped in traffic for a long period of time. Flows well.  
Not having to stop.  
If I forget and turn down the wrong street, I can keep going around until I find it again.  
I don't mind driving through it. I like the fact that the Masonic Temple got some \$ out of it and repaired the furnace!  
Nothing.

#### DISLIKES

I wish it were a little bit bigger...People adjusting to it well, still some do not yield.  
Users don't signal...you have to wait for them to clear.  
People who do not know what to do.  
Some people don't yield and use signals.  
People who do not yield to you when you are in the circle.  
"No one" knows the rules.  
Yield problem on Main Street.  
People going up Main Street don't yield.  
People don't yield, confusing.  
People learn what yield signs mean.  
People going up Main Street not yielding.  
Extremely apprehensive, people not yielding, got to take in whole thing...if nobody there it's great.  
People don't use directionals.  
Funny lip, friend blew out tire.  
More confusing now.

Near accidents because people stop, yield problems.  
I hate people who don't yield coming in or signal while they are inside.  
Never sure where people are going to go out of circle--don't use directionals; lived here all my life and never had any problems with old intersection.  
Lot's of people don't know how to use it.  
Yield problem.  
Cost, money that was spent, backed up traffic during school time.  
Some people don't yield when they are supposed to--which could cause an accident because they dart right into the roundabout when it is not their turn.  
People still stop vehicle in the middle of the roundabout or sometimes don't yield from the Spring Street side.  
People don't yield, slows the flow of traffic.  
People don't use turn signals. I avoid it as much as I can. Someone failed to yield today. Center ugly. Main Street cars from downtown don't slow down.  
Bad-turn-signaling drivers!  
People do not yield, do not pay attention.  
Some people who stop who are in travel way.  
People do not realize the traffic rules--how and when to enter the circle, right-of-way.  
People approaching the roundabout too fast.  
(1) People (cars) coming to roundabout don't yield to drivers in roundabout--need more signs, cops on hand, something! (2) Cross walks need to be much further from intersection--one pedestrian can cause gridlock of entire intersection (and I see it often) 1/2 block away.  
Probably should have a wider lane.  
Nuisance.  
Confusing to out of town people.  
Aesthetics issue, somebody just wanted to put a roundabout there, there wasn't a problem, didn't improve anything, money could have been spent on more priority issues.  
Grassy portion should be larger--looks.  
Aesthetics, [apron issue], too many signs  
Visually poor--ugly, too much blacktop.  
Cutting down on the middle green, cut down Masonic Temple trees.  
Center part is ugly--would like it to be better.  
Ugly and aesthetically sour ramp area--paint and put in textured concrete or paver brick: do something about the appearance.  
I think the middle portion is too large and difficult to see.  
Paved apron.  
The semi-raised inner circle is wasteful and confusing.  
Center plate.  
Tarred area [apron] not well marked, make travelway wider.  
The apron; so many signs; and people still don't know who has the right of way.  
Going up Main Street takes a couple seconds more, have to be extra careful with kids crossing, the narrowness of entries.  
Seems confusing to many. Have personally been cut off .  
Traffic backup.  
Right hand corners on exit sections stick out too far for trucks.  
Small enough so people don't signal, too small.  
Nearly been killed more than ever before. Boy hit on a bicycle this summer.  
Wasting time, causing cars to congest and large trucks have to go up on curb.

The rise in the middle.

I think the money could have been more wisely spent--the roundabout saves no more time and people do not want to yield.

As you enter from the east side of Main Street, turning too soon to the right may damage tires. Need better signing, i.e., "vehicles in circle have right of way," "use directional signals when entering circle to indicate your intended route." We could use a couple of these in Barre to improve traffic flow and safety! I have used the old intersection and new roundabout for 10 years while entering or leaving the Masonic Building...The improvement in egress and smooth traffic flow is very noticeable particularly at 4:30 p.m.-5:00 p.m. with increased traffic from Elm, Spring to Main Street. Suggest inner (upper) circle be striped with yellow to indicate not normal travel lane.

Appearance needs improving (the collar area), even green paint would help as a driving visual clue and color enhancement.

Dangerous for pedestrians?

Worry someone will come up on sidewalk and hit me or my dog. Took our crosswalk at Brown Street.

How it handles pedestrian traffic--think it is more dangerous.

Sometimes kids do roller blading in center...some stop in travelway, need education for drivers to know those in travelway have right-of-way.

The backup of traffic on Spring Street and coming down from Towne Hill on Main Street.

It's slow.

Do not understand what problem it was solving; lip not high enough on apron to keep drivers off. Longer to walk on Spring St. side of Main Street--preferred side of street to walk (particularly in winter).

Kids know how to drive roundabout--older people don't know how! (They should learn.)

Difficult to judge entering gap, some going too fast on travelway, needs to be "slow ahead sign"

Am convinced money could have been spent more wisely on failing infrastructure elsewhere.

It's too small, completely unnecessary and many people don't know exactly what to do--they stop and wait, they don't signal, cars are held up unnecessarily and it's an accident waiting to happen some day.

Negativity of stupid people about roundabout.

Waste of money, have to stop coming home--did not have to before.

#### QUESTION 4: WHAT DO YOU MISS ABOUT THE OLD INTERSECTION?

(NEGATIVE OR NEUTRAL)

Nothing. (24 responses the same).

Nothing really.

Not much.

Nothing, it was a bottleneck getting to Route 12 from Main Street School, children and pedestrians had poor crossings.

Nothing (used [intersection] 20 to 30 times a day).

Not a dam thing.

Nothing, gotten used to it.

Don't miss it.

Miss nothing.

Do not miss a thing.

Don't miss anything.

No, nothing.  
Not much of anything.  
Can't say that I miss it at all.  
Hardly anything.  
I don't think I miss a thing.  
I don't even remember.  
Insecurity of trying to dash across traffic, sitting and waiting for traffic, and speeders passing Main Street School.  
Neutral...other places need it more.  
Frustration.  
Watching semi's try to get through!  
Miss late at night being able to get through intersection fast!  
Could drive faster through the intersection.  
Lost tourists trying to turn around.

(POSITIVE)

From Spring down Main I had to clearly yield before, not as clear now.  
Miss the flow, upper Main Street down; less to think about.  
Clear expectation of "right of way" rules.  
Like hedges at edge of triangle.  
Seemed to work adequately.  
I miss through-travel section on Main.  
I never thought about it before--it seemed to work.  
Felt very comfortable with it--guess you get used to it.  
Never had a problem with it.  
Little less confusing.  
Was prettier, more grass before.  
I liked it.  
Liked walking down Main Street straight through. I understand it was not so safe--cars travel faster.  
Drivers knew "what to do" and when to go/stop (by looking) large vehicles could go through with no problem.  
Going up Main Street not having to slow down.  
You do not have to wait turn to go through on a bike, because on a bike you have to be on the street.  
The crosswalk between the Inn and the Gary Home.  
Nothing, it was all right.  
Miss the old sidewalks, longer to walk around on Spring Street side; thinks conditions were safer for cars, less "near misses"; do not use City tax money to improve apron.  
Ease of walking crossing--less confusing.  
Why did they do it--lot less cross walks.  
Continuity of Main Street itself as a street rather than an intersection.  
Big trees you took down.  
Smaller scale, the appearance, because of the large mountable apron now.  
It was simple and quick without congestion.  
Unnecessary to do, cost, it might be better.  
Money could have been better spent, simplicity, yard cut out at Masonic Temple, center is ugly.  
Quicker to travel from upper Main St. leg

We were able to place a temporary sign in the grassed-in fork area...to advertise the craft fair, etc.

More simpler, more confusing this way.

The change. People now have learned what to do--people confused at first.

Convenience...

Nothing, convenience of getting around with through traffic.

Lawn taken away from the Masonic Temple.

Masonic Temple land lost.

#### (MISCELLANEOUS)

Parking on Spring Street makes things cluttered.

We could use some of these [in Burlington]

Just another way to spend tax dollars when the roads of the City are a disgrace.

(Morrisville) No we do not want/need a roundabout in Morrisville.

I feel that the money could have been spent in a more productive way, i.e., repair pot holes, resurface streets, etc. It seems to be a whim of someone who wanted to say Montpelier is the only state capital with a roundabout. I think the Keck family wouldn't want their name associated with it after the negative reactions of the citizens and homeowners of the City of Montpelier.

Husband rear ended.

The crosswalk at Langdon Street should be moved to State and Main Street, slows traffic down...

Spring and Elm Street intersection is a bad intersection, need to do something [roundabout?] about it.

Montpelier high taxes.

Not convinced it was worth the money.

School and Main Street still a problem even with bulb-outs.

## REFERENCES

(1) "Relative Safety of Modern Roundabouts and Signalized Cross Intersections," Leif Ourston, P.E., Santa Barbara, California (1996)

(2) "The Safety of Roundabouts in the Netherlands," Traffic Engineering and Control, March 1994.

(3) Ourston, op. cit., p. 5.

(4) "Modern Roundabouts and Traffic Crash Experience in the United States," Aimee Flannery, Transportation Research Board, January 1996.

(5) "Montpelier Roundabout Final Report Main Street/Spring Street Montpelier, Vermont," Amy L. Gamble, P.E., Vermont Agency of Transportation, Montpelier, Vermont, 1996.