

00930 & 00962
Direct Tension Indicator and Turn-of-Nut Tightening for Luminaires and Traffic Signal Supports

8 Bolt Mast Arm Connections

TM 650 – References Mast Arms and Luminaire Arms

TM 652 – 8 Bolt Arm Connection Details and Arm Connection Notes: See General Notes on TM651

TM 651 – Note 22: Tighten 8 Bolt Arm Connection bolts in accordance with 930.40(d)

***930.40(d)(2)(a) Direct Tension Indicator (DTI) Tightening**

After attaining a snug-tight condition, tighten all fasteners in the connection by progressing systematically from the most rigid part of the connection to the free edges until all of the spaces between the direct tension indicator protrusions refuse entry to a 0.005-inch feeler.

***00930.49(e-2) – Bolt Inspection**

Upon completion of bolted joint, inspect a minimum of 10 percent but not less than 2 bolts in each joint. (Check gaps with .005" feeler gauge.)

General

Direct Tension Indicator (DTI) Washers have protrusions that, when compressed, indicate adequate tensioning.

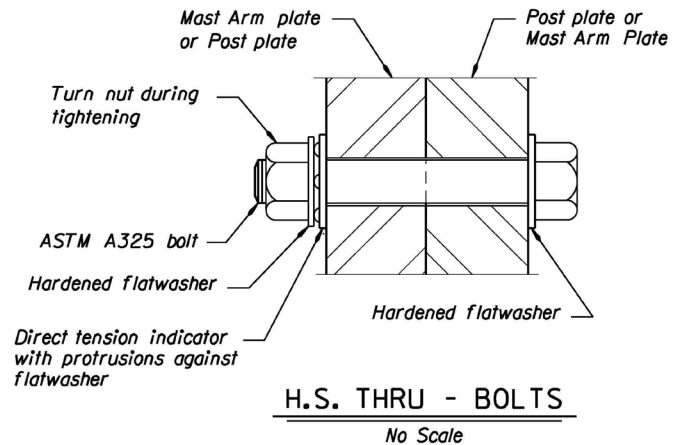

TM652 H.S. Through – Bolts Detail
(Detail 1 – Correct DTI Washer Orientation)

DTI – Key Inspection Points

- Ensure washer orientation is correct (protrusions facing hardened washer)
- Insert feeler gauge in each space between protrusions
- Insert the feeler gauge pointed towards the center of the bolt
- Inspect from the bucket truck (fall protection required)

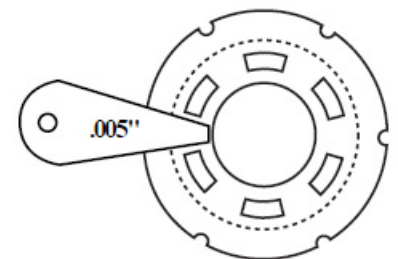

Notches on the DTI mark the center of the protrusion spaces. A feeler gauge is included in the hardware shipment.

[Click here to see it on YouTube!](#)

***updated for projects bid on/after 12/1/2016**



Bolt Tightening with Cheater Bar
(May be difficult to achieve proper tensioning)



Bolt Tightening with Multiplier
(Best practice for achieving proper tensioning)

Continued on back

4 Bolt Luminaire Arm Connections & Anchor Rods (Turn-of-Nut)

TM 652 – 4 Bolt Arm Connection Details and Arm Connection
Notes: See General notes on TM 651

TM 650 – See details on TM 629

TM 629 – Tighten Anchor Bolts and Arm Connection bolts in accordance with 962.46(j)(2)

TM 651 – Note 21: Tighten 4 Bolt Arm Connection bolts and anchor rods in accordance with 962.46(j)(2)

962.46(j)(2)(a) Anchor Rods for Signal Supports
Rotate each top nut past snug as shown in (d).

962.46(j)(2)(c) High-Strength Bolts in Luminaire Arm-to-Pole
Install high-strength 4-bolt connections....Rotate each top nut past snug tight as indicated in (d).

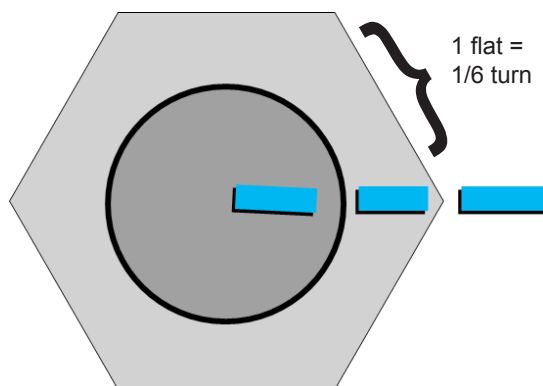

After Snug Tight, mark bolt, nut and plate prior to tightening.

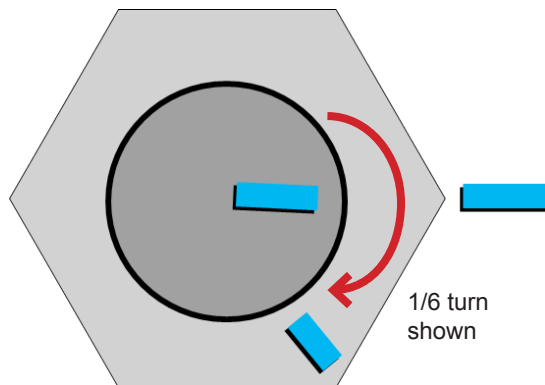

Final tightening: Rotate Past Snug Tight per 962.46(j)(2)(a)

Technical Contacts

Terry Thames
Structure Quality Engineer
541.686.7598
terry.r.thames@odot.state.or.us

Jaimé Viramontes, Sr.
Assistant Structure Services Engineer
503.986.5453
jaime.viramontes@odot.state.or.us

962.46(j)(2)(d) – Final Tightening

Connection Type	Rotation Past Snug Tight
ASTM A307 Anchor Rods	30° (1/12 turn)
ASTM A449 Anchor Rods	60° (1/6 turn)
ASTM F1554 GR. 55 Anchor Rods	60° (1/6 turn)
ASTM A325 4 Bolt Connection	60° (1/6 turn)

00962.46(j)(2) – “Snug Tight” is the tighness that exists when all plies of the joint are in firm contact, and can be obtained by the full effort of a worker on the end of a 12-inch long wrench.

Turn-of-Nut Key Inspection Points

- Luminaire connections must be observed/inspected at ground level, prior to erecting pole
- Inspect leveling nuts and washers to ensure full contact with base plate prior to installation of top nut
- Be on-site for inspection



Tightened Bolts

Photo shown for illustration of bolt markings only.
Signal anchor bolts require two nuts per bolt.

Sampling of High Strength Bolts, Nuts, and Washers (NTMAG Section 00930 & 00962.10)

Check to see if ODOT Materials Lab (971-673-7002) has sampled and tested the bolts, nuts, and washers to be used. If not previously tested, sample in the field for each lot to be used on the Project. Submit samples to the ODOT materials laboratory for testing. Do not use high strength bolts, nuts, and washers without passing laboratory report and proper quality documents.

Spec Notes are prepared for inspectors by the Construction Quality Assurance Unit to provide background information around design elements and specifications. For additional Spec Notes, visit us at <http://www.oregon.gov/ODOT/HWY/CONSTRUCTION/Pages/QAIndex.aspx>.

If you have an idea for a Spec Notes topic, please e-mail us at ODOTConstructionTraining@odot.state.or.us or contact us at 503.986.5453.