

Unit 7 Lesson1: Introduction to Curb Ramp Styles Identification Concepts

 **Course Navigation Tips:**

- To complete each lesson, you must interact with the audio narration at the top of each section.
- You may drag the toggle on the playback bar to the last 5 seconds and let it play. This will allow the system to note it as complete.
- You are encouraged to complete the entire unit before closing in case your progress is not saved.

 **You must click on all images before moving on to next Lesson.**



03:21

Start Audio Narration

Ramp Run Orientation to Determine Curb Ramp Style

In this Unit we will be discussing different styles of curb ramps as illustrated in the Oregon Standard Drawings and ODOT design manuals.

Two terms that will be used often are perpendicular and parallel to describe curb ramp systems. Perpendicular and parallel describe both the orientation of a curb ramp running slope and two separate styles of curb ramp systems.

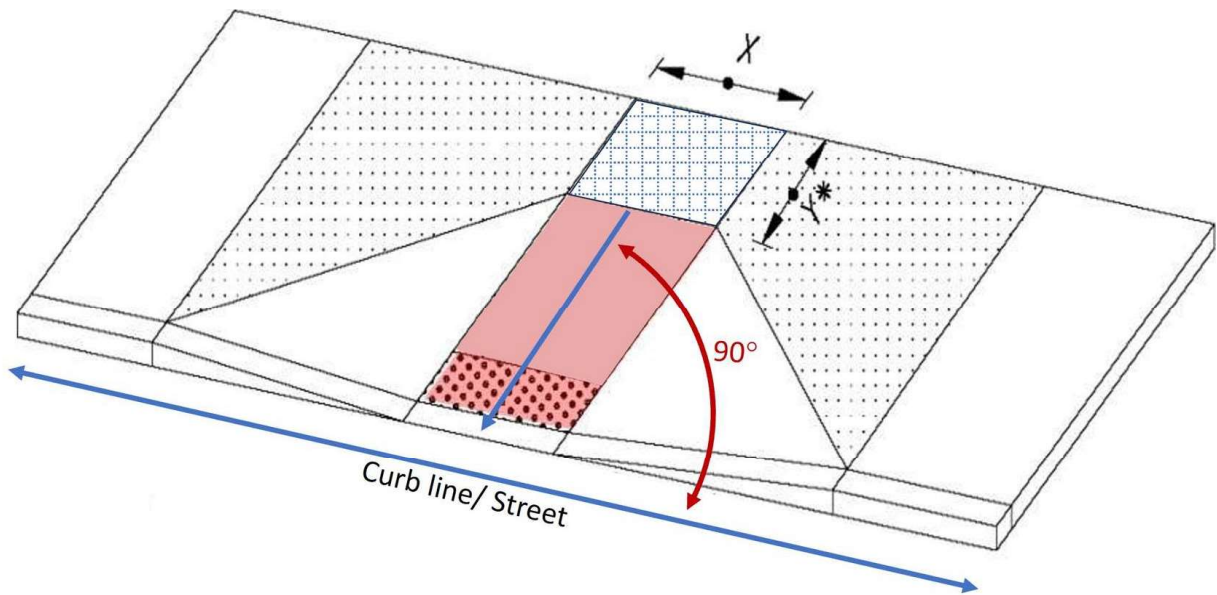

Perpendicular Ramp Run, 90 Degrees to Curb Line

A **perpendicular ramp run** is constructed at an angle of 90 degrees to the curb line or direction of roadway travel.

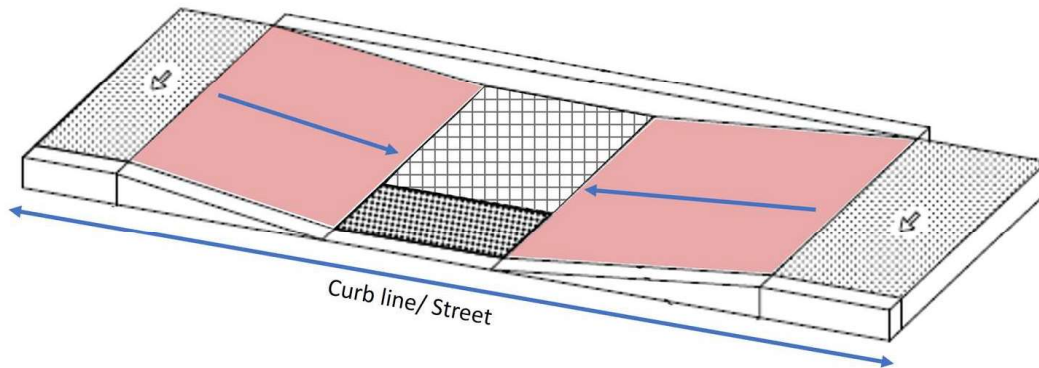

Parallel Ramp Runs, Parallel to Curb Line

A **parallel ramp run** is constructed parallel to or does not intersect the curb line, or the direction of roadway travel.

Perpendicular and parallel curb ramp system styles will be described in the following lessons. The fundamentals for curb ramp system measurements are largely the same with some specific instructions for various curb ramps system styles. Components for curb ramp systems were described in the previous lesson with brief measurement concepts. This unit will elaborate more on measurement practices based on the curb ramp system style.

Ramp Run Numbering

Unit 3 described how to number corners and curb ramps on the State Highway system. The Ramp Run numbering convention uses the same counterclockwise convention as corners and curb ramps.

In general:

- The Ramp Run connected to the street is Ramp Run 1
- The Ramp Run on the right side of the crosswalk entry point is Ramp Run 2
- The Ramp Run on the left side of the crosswalk entry point is Ramp Run 3

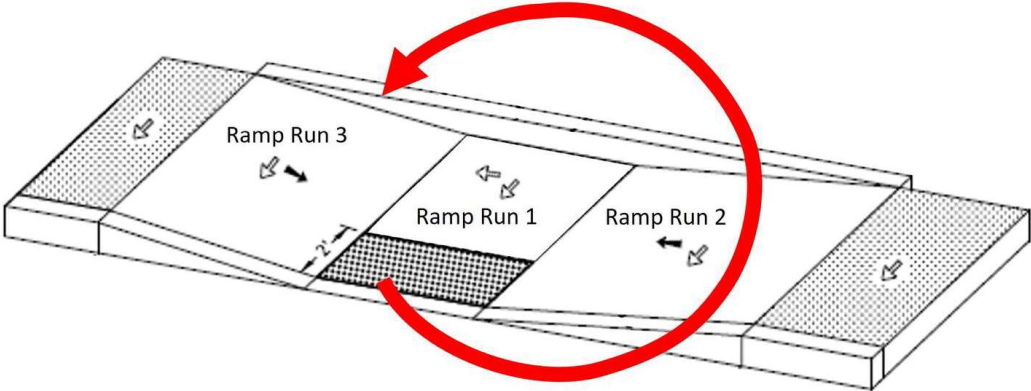

Ramp Run Numbering Convention on a Parallel Curb Ramp

The 7 Curb Ramp System Styles for ODOT Inspection

There are 7 types, or styles, of curb ramp systems described for construction of ODOT facilities on or along the state highway. They are:

- Perpendicular
- Parallel
- Combination
- Cut through Island
- End of walk
- Blended Transition
- Unique Design

Each style of curb ramp system has its own Curb Ramp Inspection Form. It is important to know how to distinguish each style of curb ramp system so that you choose the correct form to use when conducting an inspection.

The following is a detailed description of each style of curb ramp system, their unique features, and measurements needed for the Curb Ramp Inspection Form. The curb ramp system measurements concepts are applied to each curb ramp system style based on the applicable components for that curb ramp style. Variations in inspection practice or unique differences are discussed with each curb ramp style.



Review all figures and advance audio to the end before moving on.

CONTINUE

Unit 7 Lesson 2: Perpendicular (PR) Curb Ramp Style and Measurements

 You must click on all images before moving on to next Lesson.



03:28

Start Audio Narration

A perpendicular curb ramp system has a running slope that is perpendicular to the curb or street. The ramp orientation requires a turning space or landing at the top of the ramp run touching the street boundary. **The two main components of the perpendicular ramp are Ramp Run 1 and the turning space or landing.** Sometimes these curb ramp systems include side treatments including flared slopes or a return curb with a non-traversable buffer. The side treatment might not be the same for left and right sides of the ramp run. Refer to Oregon Standard Drawings RD910 through RD916 for perpendicular curb ramps systems and the construction requirements.

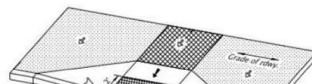

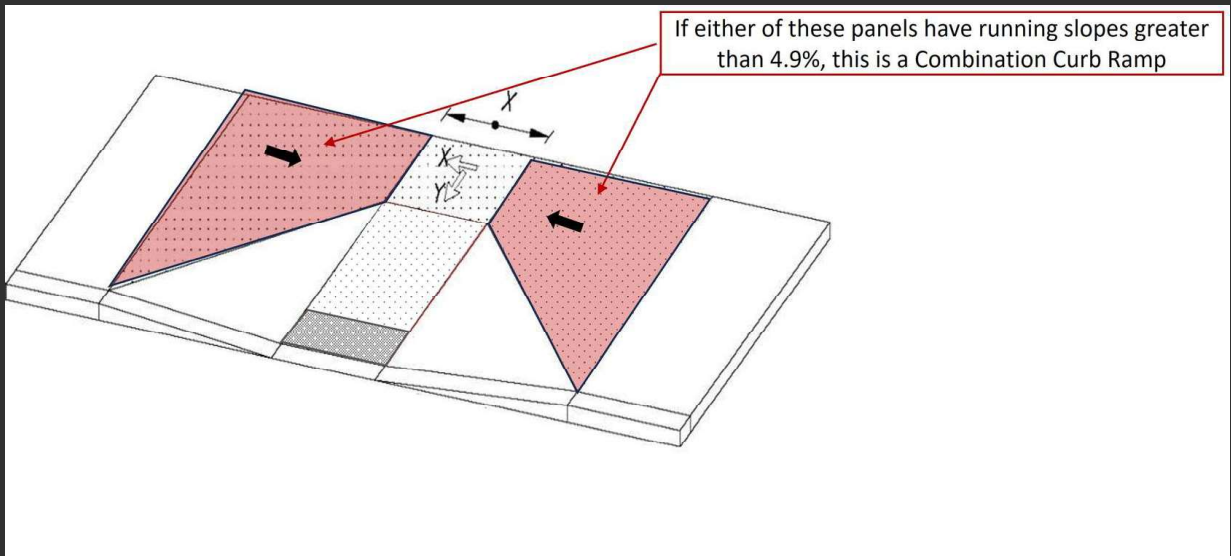

If either sidewalk panel adjacent to a Perpendicular Ramp are greater than 4.9%, it is a Combination Curb Ramp

If one or both sidewalk panels adjacent to the turning space/landing are sloped greater than 4.9%, they are measured and recorded as ramp runs. When this happens, it is now recorded as a combination style curb ramp system NOT a perpendicular style curb ramp system. Use the combination curb ramp inspection form instead. Combination style curb ramp systems are discussed in Lesson 4.

Perpendicular Curb Ramp Measurements

Ramp Run 1 (RR1) Running Slope

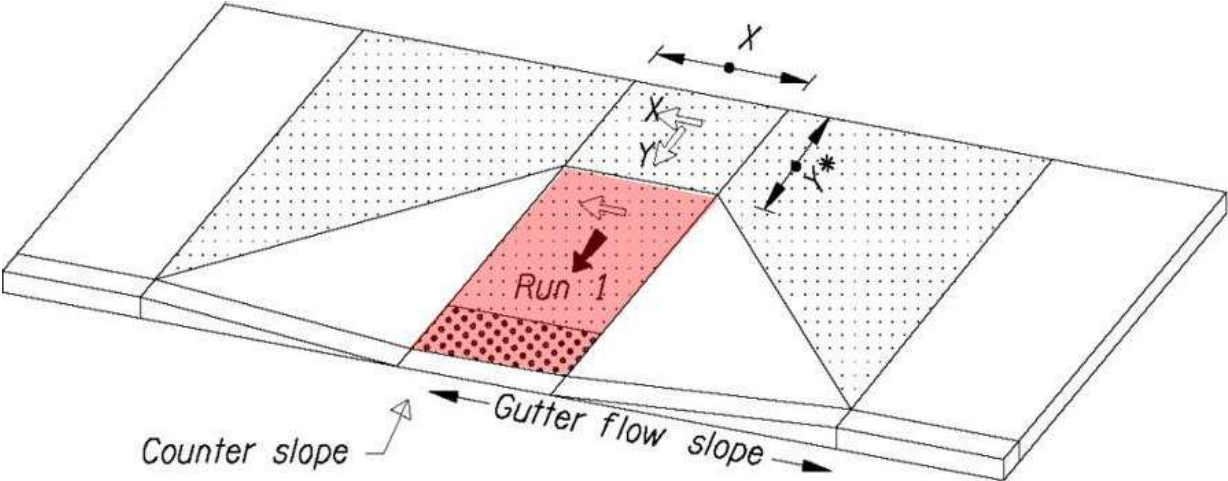

Ramp Run 1 on a Perpendicular Curb Ramp

Run Slope 1

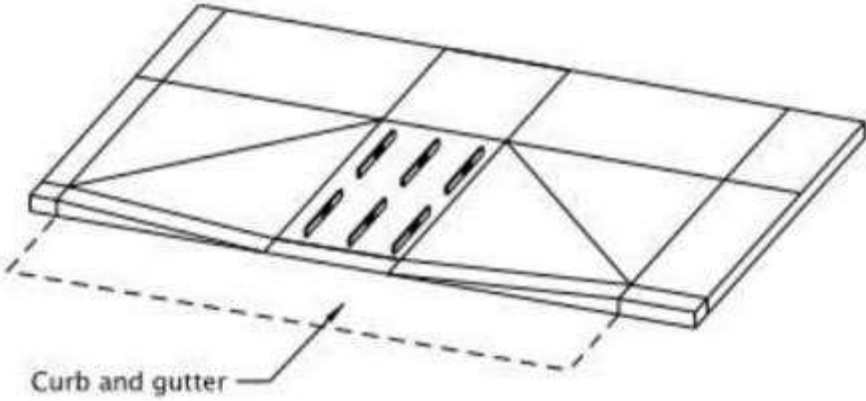

Measuring Perpendicular Ramp Run 1 Running Slope

Measure ramp run slopes in accordance with the ramp slope measurement requirements described in the earlier unit. Supplement with additional measurements when there is an evident

inconsistency in the ramp run surface or larger curb ramp widths. Record the maximum running slope measurement found. The maximum allowable running slope is 8.3% at finished construction without a design exception. The slope convention for positive or negative values applies to the ramp run slope measurement.



Measuring Running Slope on Ramp Run 1 On a Perpendicular Curb Ramp

Ramp Run 1 (RR1), Length

Measure from the back of curb to the top of ramp run at the grade break. Record the longest ramp run length. There may be a directional curb component to include in this measurement.

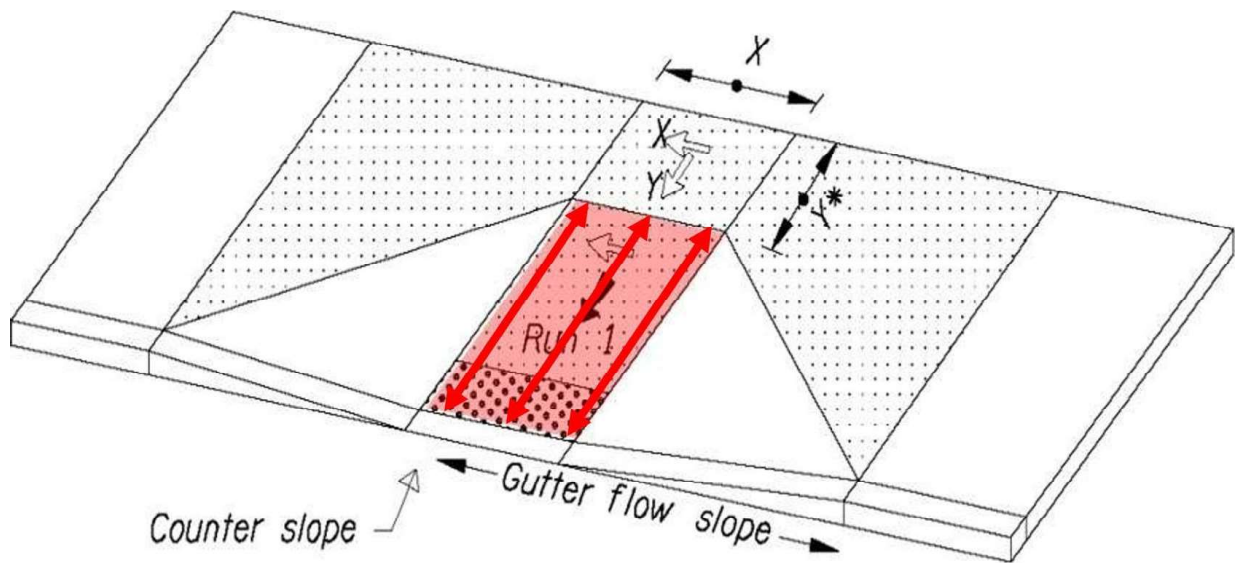

Ramp Run 1 Length Measurement on a Perpendicular Curb Ramp

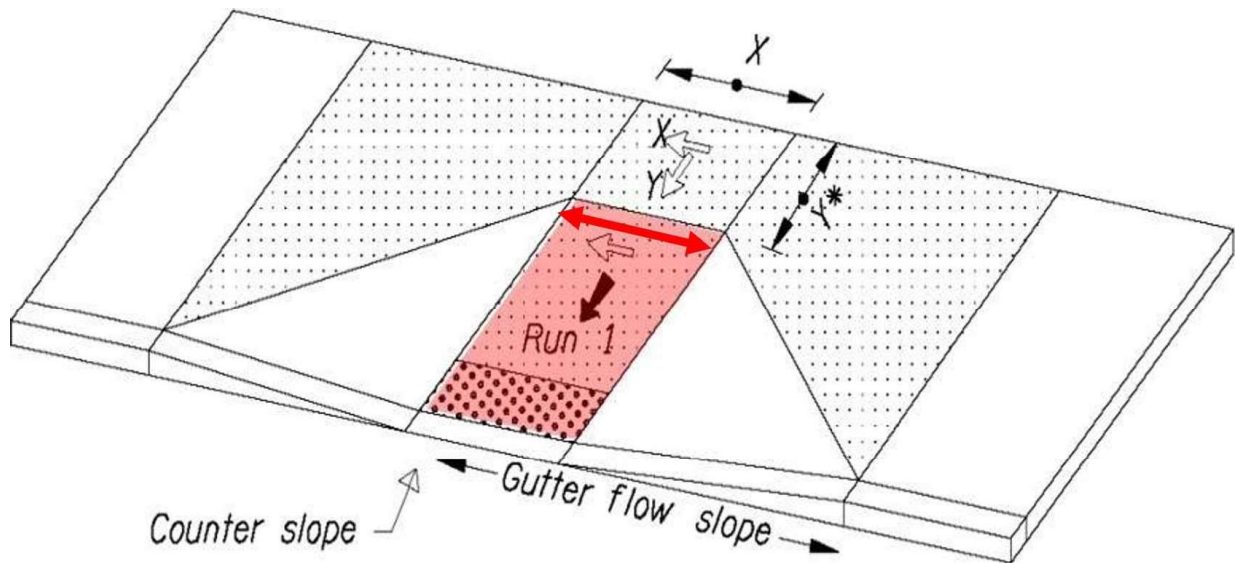

Ramp Run 1 Cross Slope Measurement on a Perpendicular Curb Ramp

Ramp Run 1 (RR1), Cross Slope 1

Take cross slope measurements within the top 6-inches, adjacent to the turning space/landing. This measurement should match the turning space/landing cross slope, denoted as X in illustration below and is recorded. These concepts were discussed in Unit 5. Ramp run 1 is allowed to warp to match the intersection condition type at the bottom of the ramp run. Cross slope 1 is recorded from the measurements taken in the top 6 inches of the ramp run for curb ramp systems that are allowed cross slope warping.

Measure the cross slope all the way down the ramp run surface. Verify that the cross slope measurements do not exceed the maximum allowable gutter flow slope based on the intersection control type.

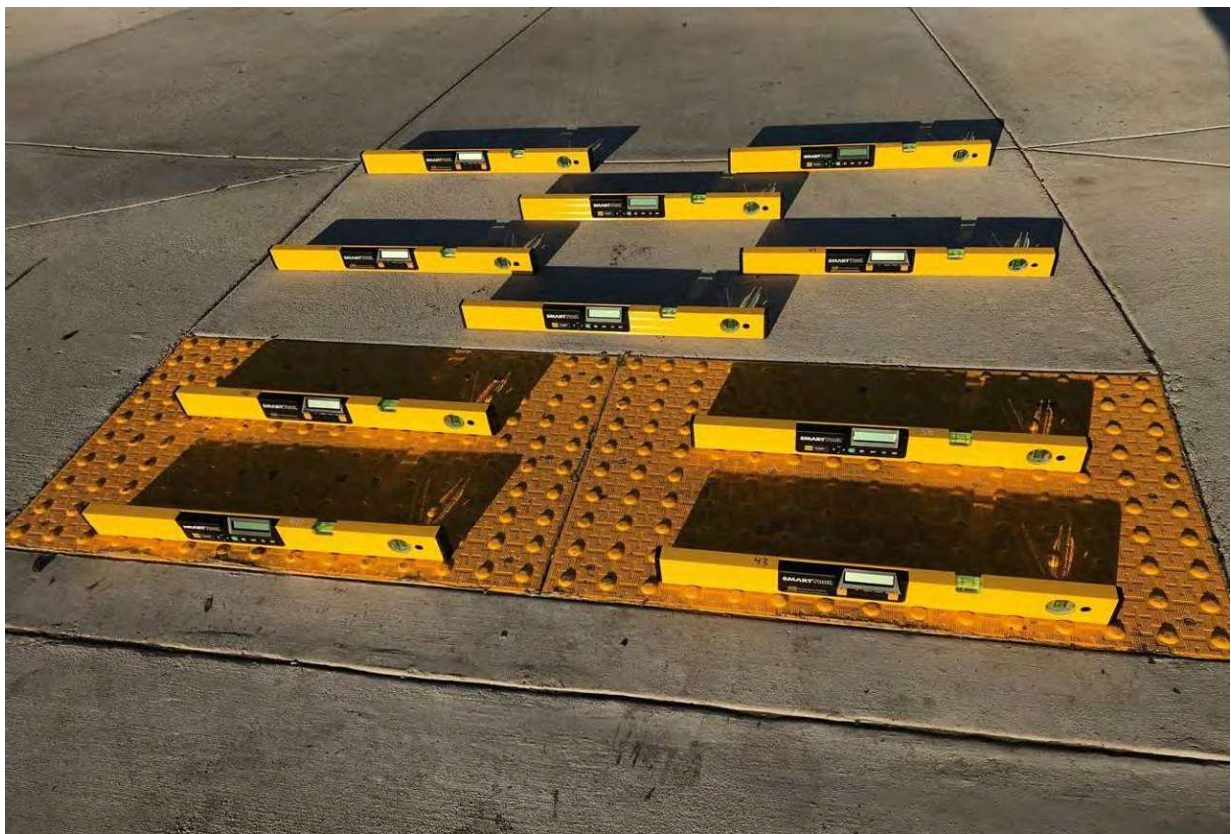

Example of how to Measure Cross Slope on a Perpendicular Curb Ramp System



Continue Audio Narration

Turn Space

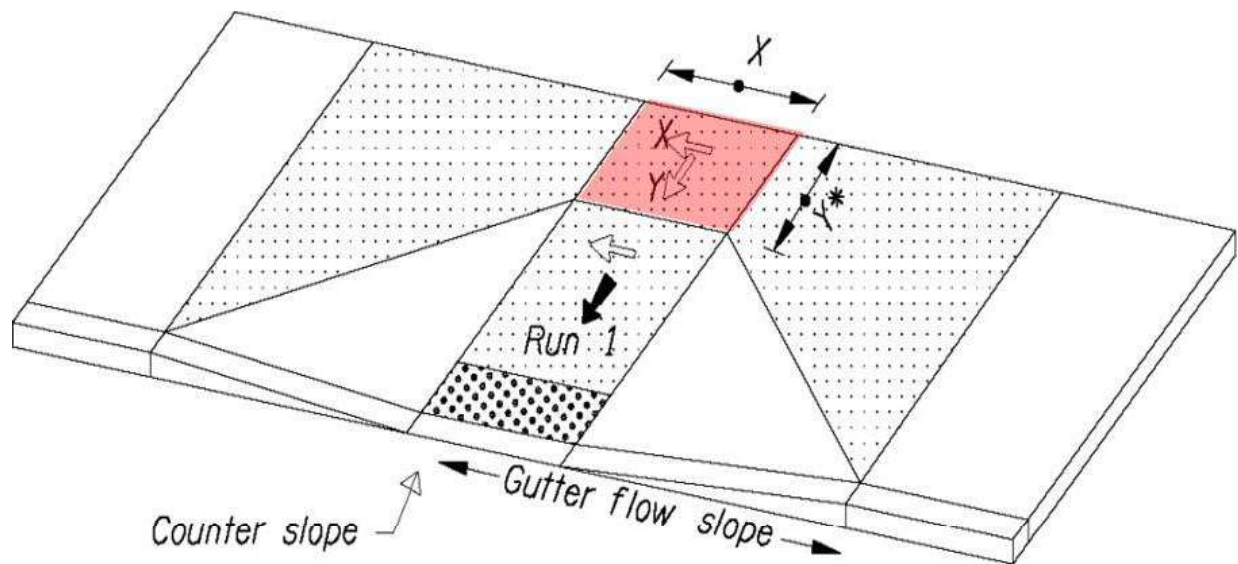

Turn Space and Landing Width/Length

The turn space/landing on a perpendicular curb ramp is typically above Ramp Run 1; however the curb ramp system may be depressed depending on the site terrain.

Turn Space Measurements

Slope X

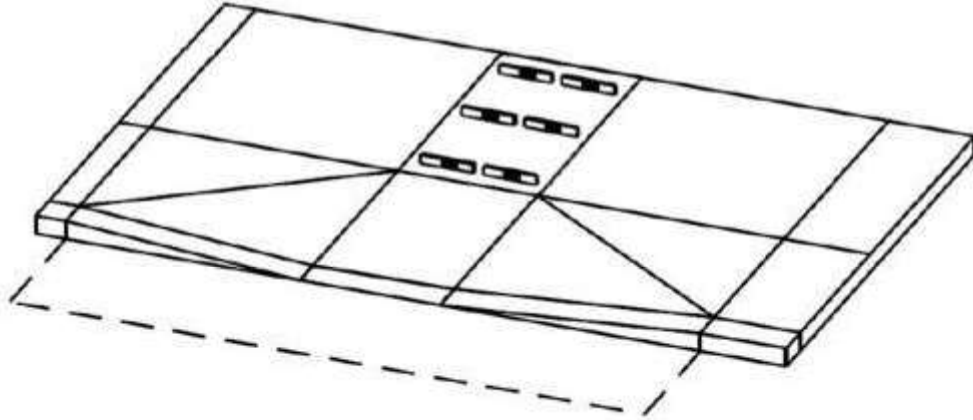

Measuring Turn Space Slope in the X Direction

Turn Space X Slope Measurements

Take measurements of the turn space in the X direction placing the 2-foot smart level perpendicular to the Ramp Run 1 Running Slope at a minimum of 1-foot increments. Record the greatest slope measurement to the tenth of a percent. The maximum allowable slope is 2% without a design exception.

Turn Space X Length Measurements

Record the narrowest width found to the tenth of a foot. The minimum allowable dimension for width is 4 feet. Comment if there is an object, such as a pedestrian pole, on the turn space.

Slope Y

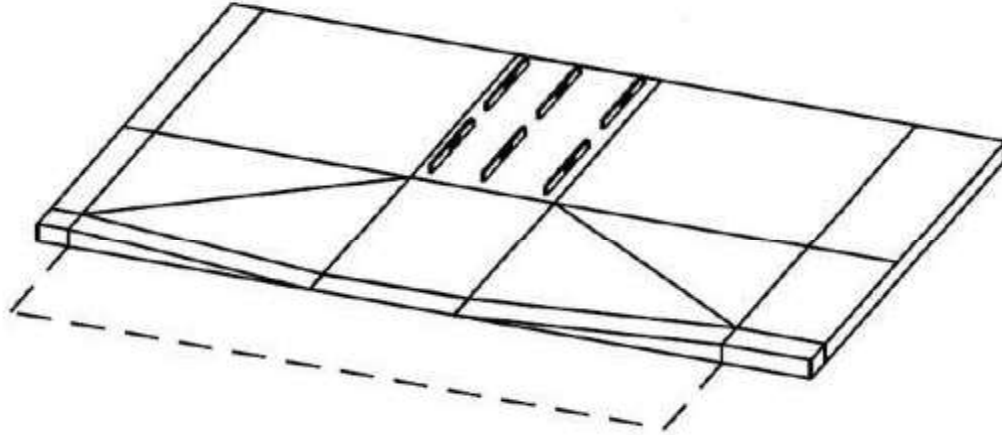

Measuring Turn Space Slope in the Y Direction

Turn Space Y Slope Measurements

Take measurements of the turn space in the Y direction placing the 2-foot smart level parallel to the Ramp Run 1 Running Slope at a minimum of 1-foot increments. Record the greatest slope measurement to the tenth of a percent. The maximum allowable slope is 2% without a design exception.

Turn Space Y Length Measurements

Record the shortest length of the turn space to a tenth of a foot. The minimum allowable dimension for length is 4 feet if it is unobstructed. If there is an obstruction at the back of walk, the minimum allowable length is 5 feet. Refer to Unit 5. Comment if there is an object, such as a pedestrian pole, on the turn space.

 Note that the turn space (X&Y) has passing criteria of $\leq 2.0\%$ and ≥ 4 feet x 4 feet. However, if constrained at the back of walk, the minimum Y length is 5 feet.

Directional Curbs

Perpendicular curb ramps may have directional curbs. Note that for ramps on a radius, the curb running slope cannot exceed 4.9%. The cross slope pass/fail criteria of the directional curb is the gutter flow slope based on the intersection control type.

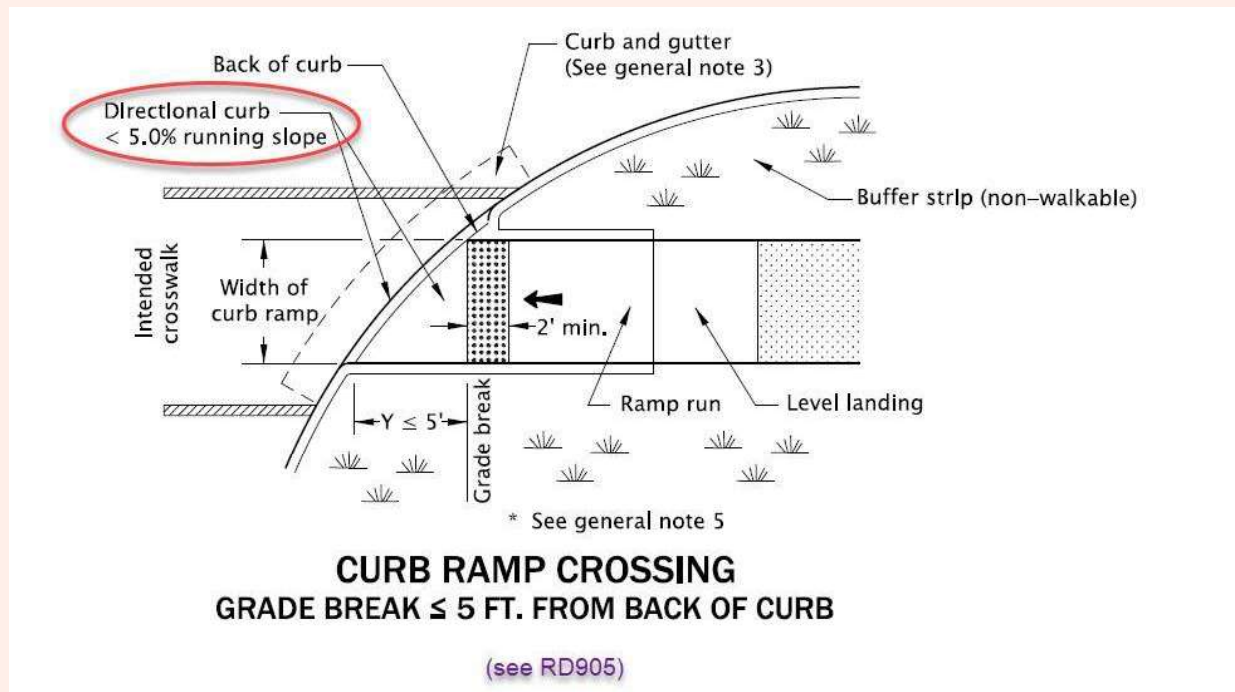

Perpendicular Style Curb Ramp with a Directional Curb

Other Measurements

The following are components or attributes of a perpendicular curb ramp that will need to be inspected. Refer to Unit 5 and Unit 6 for measuring methods.

Lips

When looking for **Lips, or vertical discontinuities**, look for:

- Vertical discontinuities across two adjacent surfaces.
- Comment on the lip location (curb lip, back of curb, edge of turn space, edge of proximity limit, utility boxes).
- Expansion joints are specified as ½ inch preformed joint filler. Therefore, keep expansion joints out of the ramp limits (RD722).

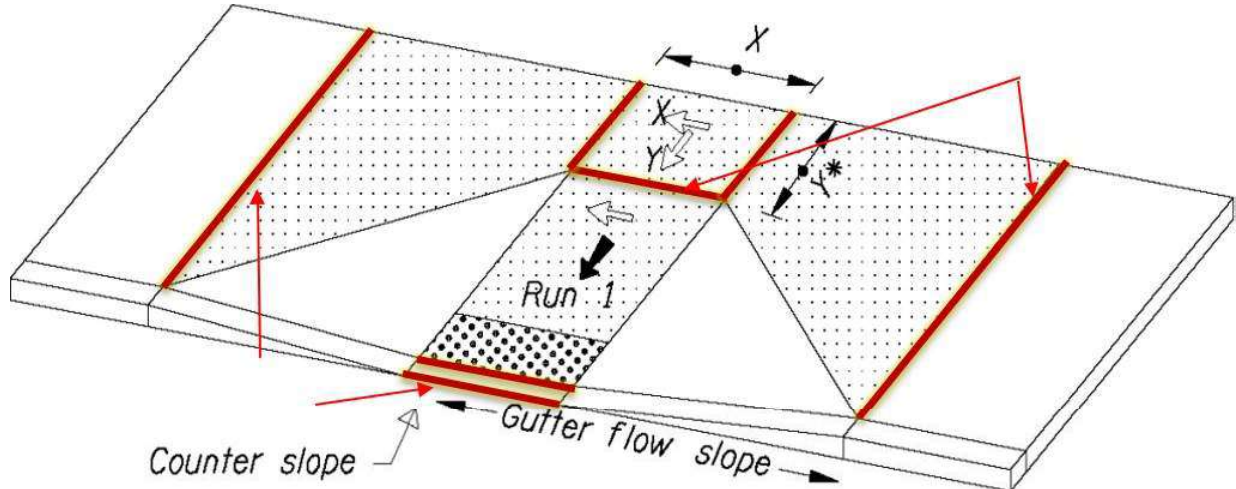

Example of Possible Lip Locations on a Perpendicular Curb Ramp

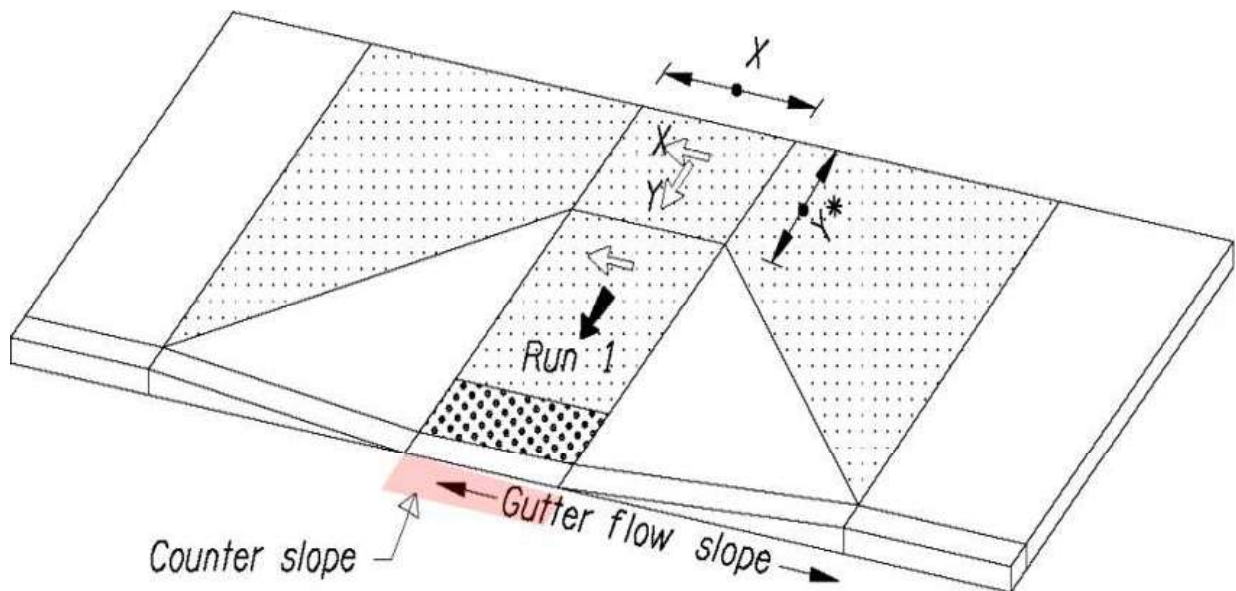

Gutter Flow Slope on a Perpendicular Curb Ramp

Gutter Flow Slope

Only measure directly in front of the ramp opening. Make sure water drains with no ponding in front of the ramp.



How to Measure Gutter Flow Slope

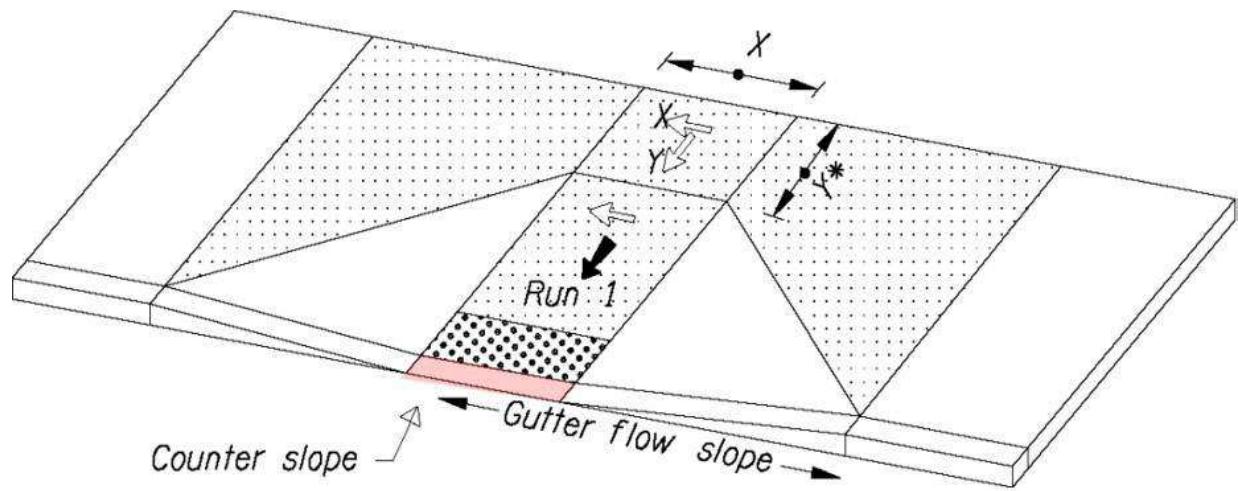

Curb Running Slope on a Perpendicular Curb Ramp

Curb Running Slope

Use the 6-inch Smart Level. Slopes toward the ramp will not be accepted, except where shown on the contract plans. **Record the average slope.**

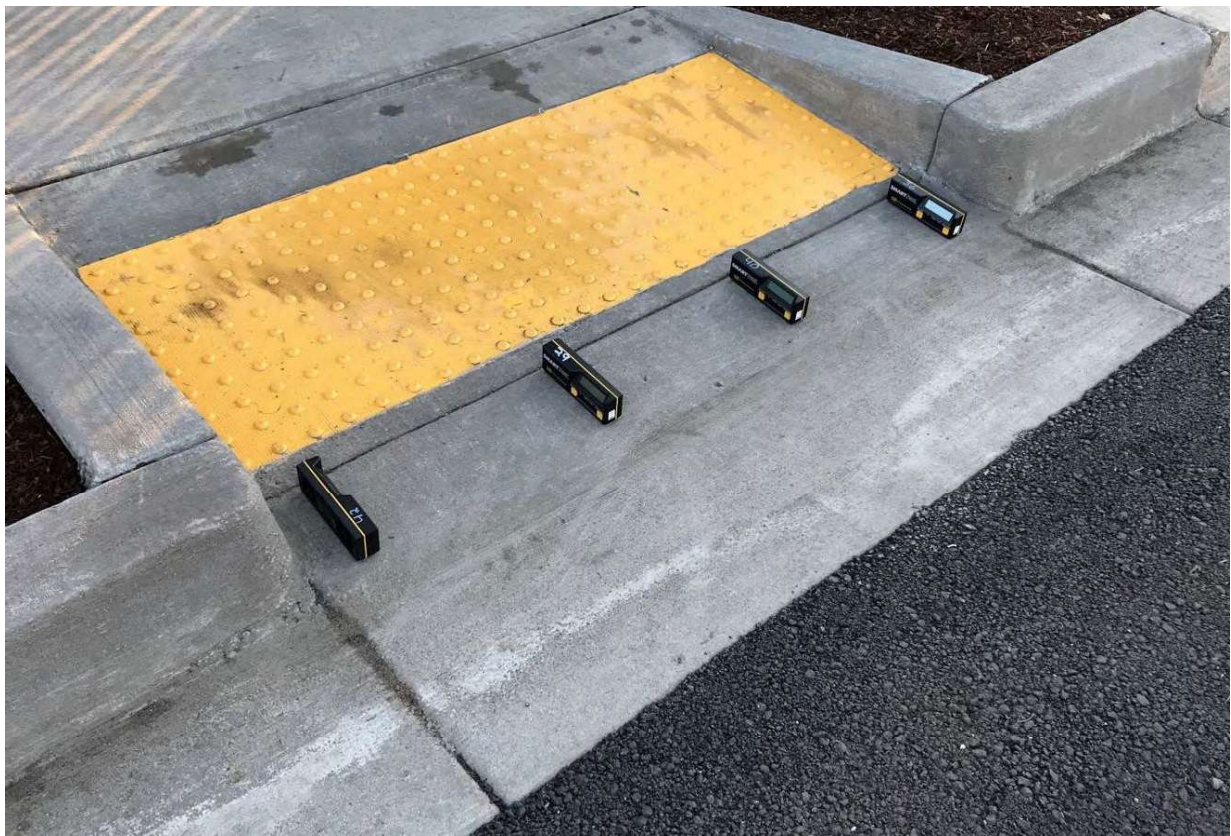

How to Measure Curb Running Slope

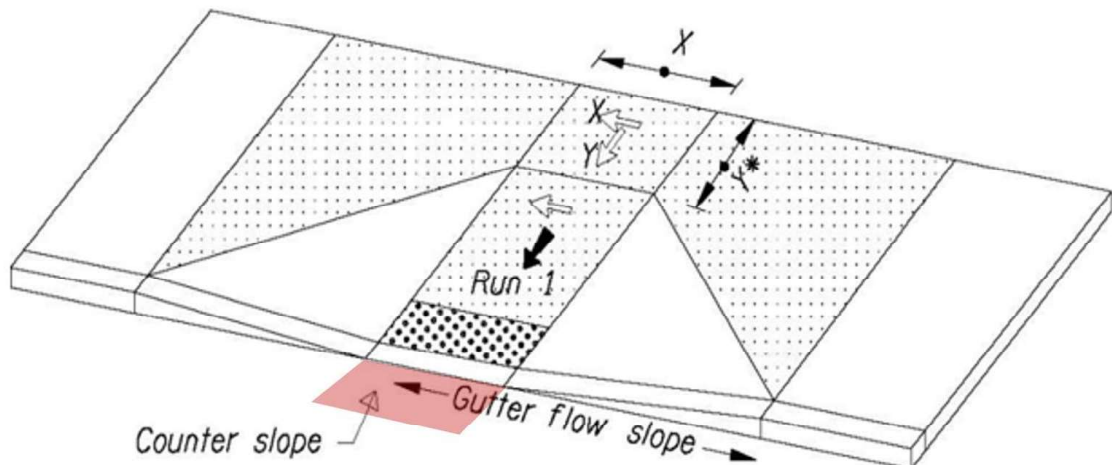

Counter Slope on a Perpendicular Curb Ramp

Counter Slope (+/-)

Use the 6-inch Smart Level on concrete gutters less than 24-inch deep. On asphalt, use the 24-inch or 6-inch Smart Level depending on pavement consistency. Counter slope is positive when it slopes up (+) from the gutter and negative when it slopes down (-) from the gutter to the center line.

Recall that the Counter Slope is determined from the gutter line. There is a positive or negative sign convention. Sloping up (+) from the gutter is positive. Sloping down (-) from the gutter is negative.

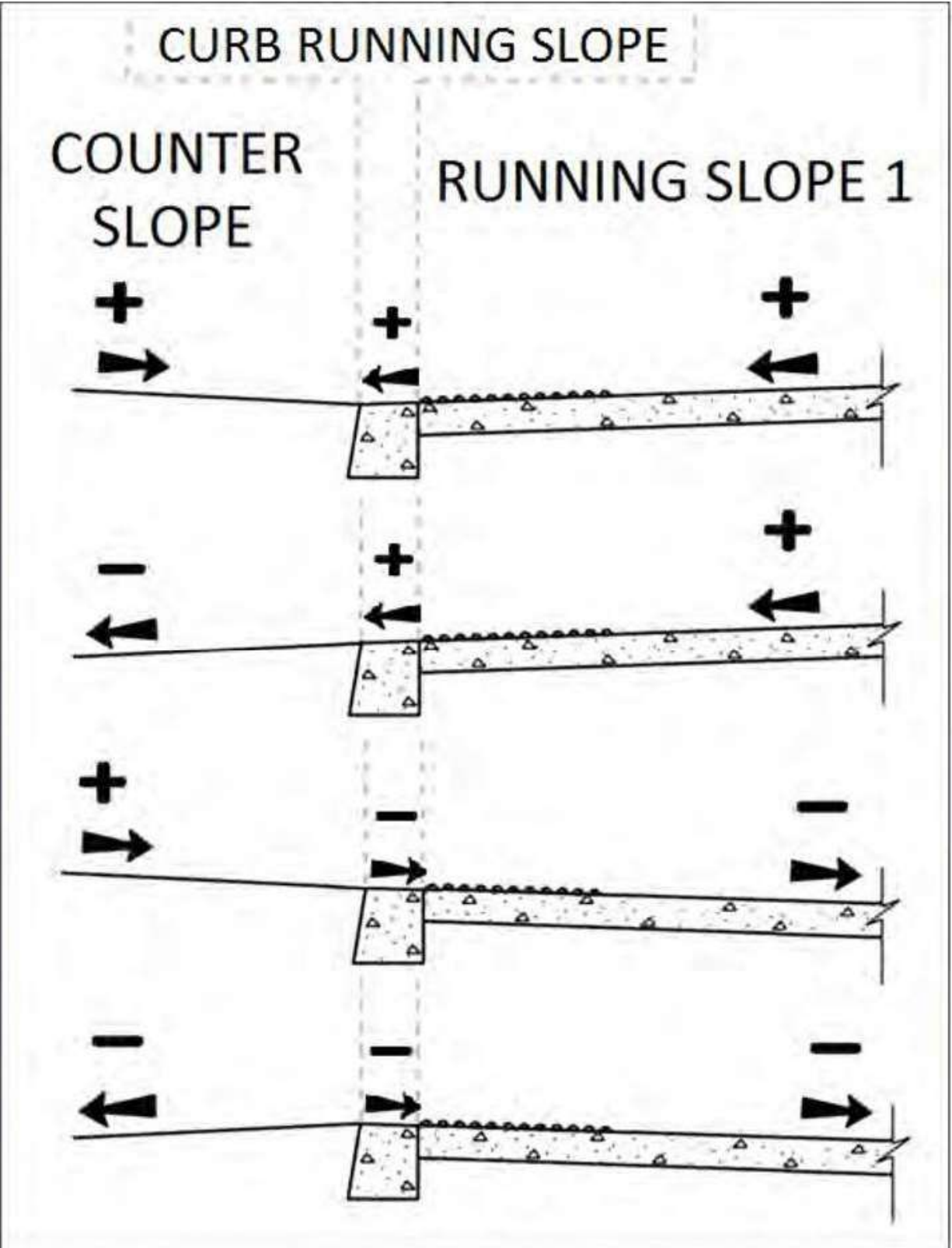

Slope Conventions for Counter, Running and Curb Slope



Measuring Counter Slope with a 6-inch Smart Level

 Review all figures and advance audio to the end before moving on.

Unit 7 Lesson 3: Parallel (PL) Curb Ramp Style and Measurements



You must click on all images before moving on to next Lesson.



02:14

Start Audio Narration

A parallel curb ramp system has two ramp runs leading toward a center turn space/landing at the bottom. A parallel ramp system has three running slopes and three cross slopes recorded. One of the unique characteristics of a parallel style curb ramp is **Ramp Run 1 and the turning space/landing are the same surface.**

In general, parallel curb ramp styles can be distinguished from perpendicular curb ramp styles because **they do not have flared slopes** and won't have a landscape buffered area between the roadway curb and Ramp Run 2 and Ramp Run 3. This construction is commonly referred to as curb tight construction. **Directional curbs do not apply to parallel curb ramp systems.** Refer to the Oregon Standard Drawings RD920 through RD929 for Parallel Curb Ramp Styles.

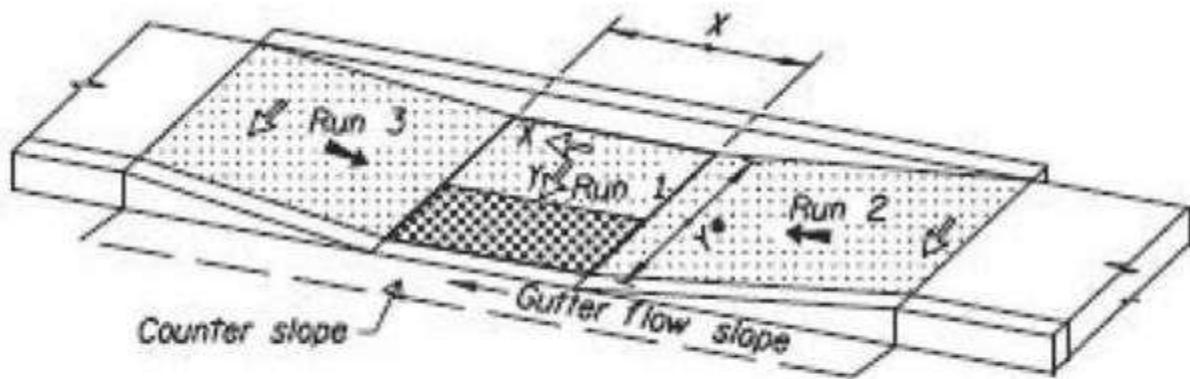

Parallel Curb Ramp Characteristics

Parallel Curb Ramps Measurements

Ramp Run Numbering

Parallel Ramps have three ramp runs. Each ramp run has a number to designate its location in the curb ramp system using the counterclockwise convention.

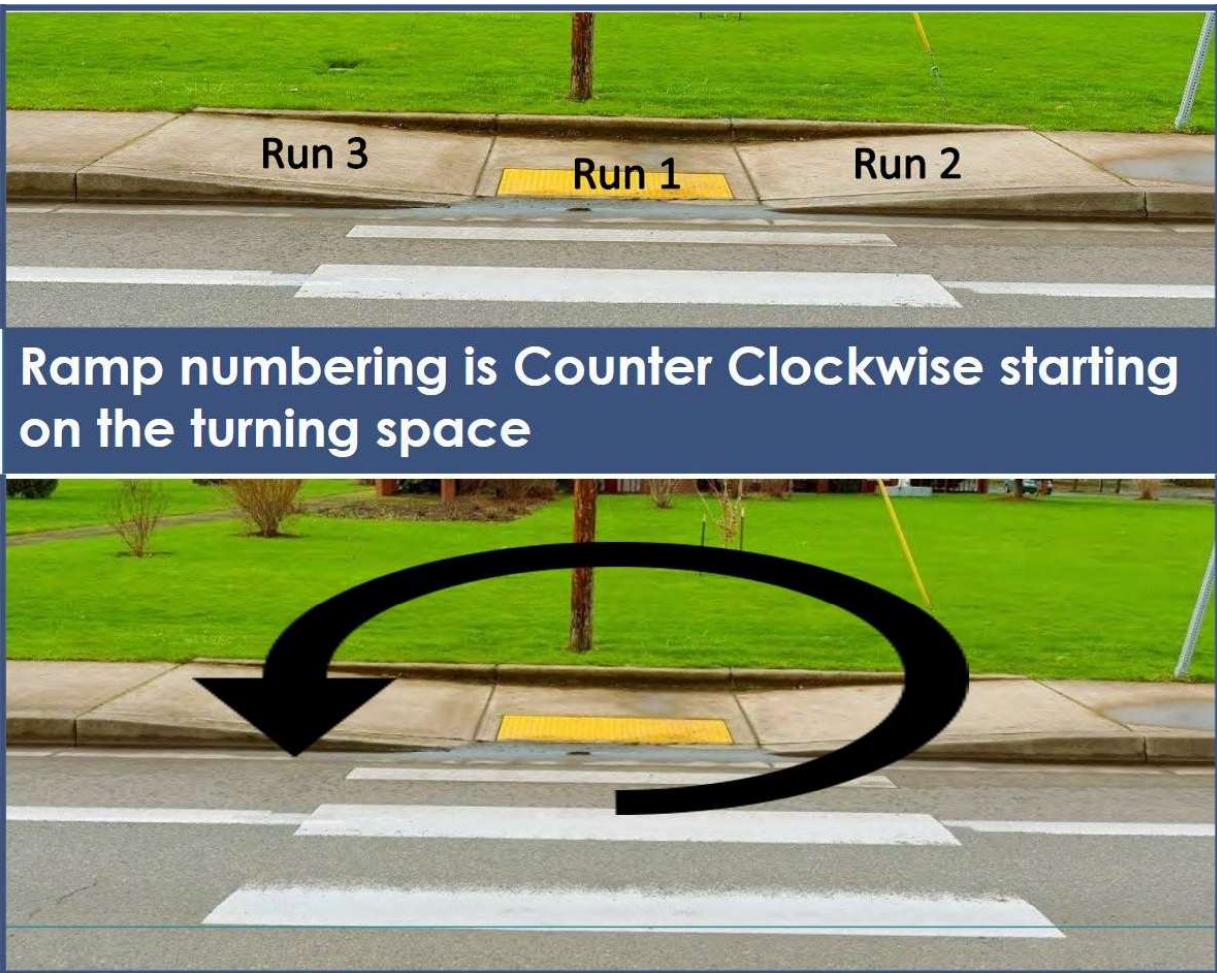

Parallel Curb Ramp Run Numbering Scheme

Ramp Running Slopes 1, 2, 3

Record the maximum values measured. **Note:** Running slope 1 = Turn Space slope Y.

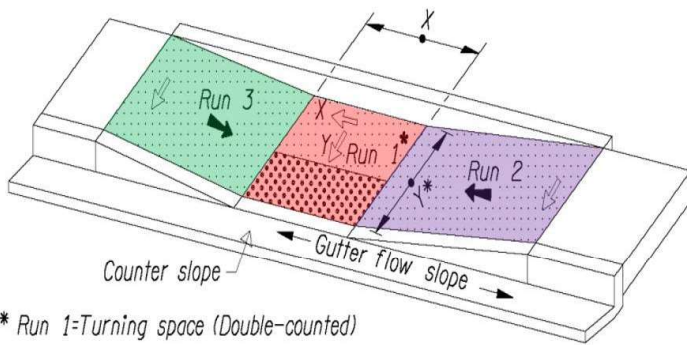

RAMP RUN 1		Pass	Fail	DE
Running Slope 1	<input type="text"/>	<input type="checkbox"/> ≤ 2.0%	<input type="checkbox"/> > 2.0%	<input type="checkbox"/>
Cross Slope 1	<input type="text"/>	<input type="checkbox"/> ≤ 2.0%	<input type="checkbox"/> > 2.0%	<input type="checkbox"/>
Detectable Warning	<input type="text"/>	(TD, X)	(N, IITD, DMG TD)	<input type="checkbox"/>
Lip Height	<input type="text"/>	0"	> 0"	<input type="checkbox"/>
Gutter Flow Slope	<input type="text"/>	≤ *	> *	<input type="checkbox"/>
Curb Running Slope _(avg)	<input type="text"/>	≤ 8.3%	> 8.3%	<input type="checkbox"/>
Counter Slope (+/-)	<input type="text"/>	≤ 5.0%	> 5.0%	<input type="checkbox"/>
RAMP RUN 2		Pass	Fail	DE
Running Slope 2	<input type="text"/>	<input type="checkbox"/> ≤ 8.3%	<input type="checkbox"/> > 8.3%	<input type="checkbox"/>
Length 2	<input type="text"/>			
Cross Slope 2	<input type="text"/>	<input type="checkbox"/> ≤ 2.0%	<input type="checkbox"/> > 2.0%	<input type="checkbox"/>
RAMP RUN 3		Pass	Fail	DE
Running Slope 3	<input type="text"/>	<input type="checkbox"/> ≤ 8.3%	<input type="checkbox"/> > 8.3%	<input type="checkbox"/>
Length 3	<input type="text"/>			
Cross Slope 3	<input type="text"/>	<input type="checkbox"/> ≤ 2.0%	<input type="checkbox"/> > 2.0%	<input type="checkbox"/>

Ramp Runs in the Curb Ramp Inspection Form for Parallel Curb Ramps.

Ramp Run 1 (RR1) Running Slope

Ramp Run 1 Running Slope = Turning Space Y direction

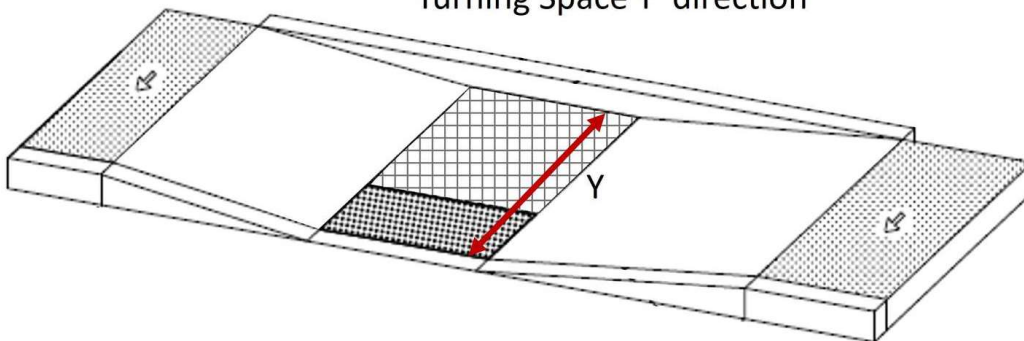

Ramp Run 1 Running Slope on a Parallel Curb Ramp.

Ramp Run 1 Running Slope is the same as the turning space direction Y. Measure the slope with the same frequency as a ramp run for a perpendicular curb ramp based on the curb ramp opening width. Record the greatest ramp running slope measurement. The Ramp Run 1 Running Slope measurements are no greater than 2% without a design exception.

Ramp Run 1 (RR1) Cross Slope

Ramp Run 1 Cross Slope is the same as the turning space direction X. Measure the slope with the same frequency as a ramp run for a perpendicular curb ramp based on the width. Record the greatest cross slope measurement. The cross slope measurements are no greater than 2% without a design exception.

Ramp Run 1 Cross Slope = Turning
Space X direction

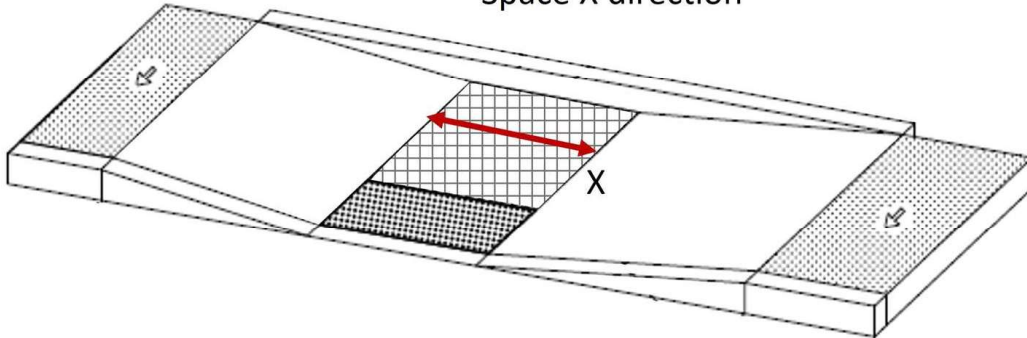

Ramp Run 1 Cross Slope on a Parallel Curb Ramp.



02:53

Continue Audio Narration

Ramp Run 2 & 3 (RR2 & RR3) Running Slope

Run Slope 2 & 3

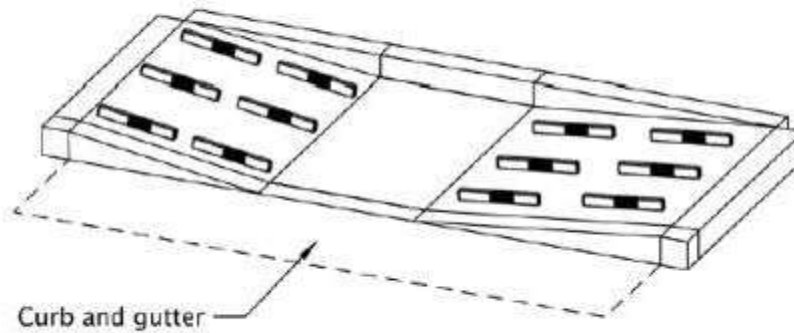

Running Slope Measurements for Ramp Runs 2 and 3 on a Parallel Curb Ramp

Ramp Runs 2 and 3 Running Slopes are measured in the direction of pedestrian travel parallel to the curve (if applicable). The highest measurement taken from any portion of the ramp run is recorded on the inspection form. The maximum compliant running slope measurement is 8.3% without a design exception.

Ramp Run 2 & 3 (RR2 & RR3) Cross Slope

The Cross Slope of Ramp Runs 2 and 3 are measured perpendicular to the direction of pedestrian travel. Record the highest measurement taken from each ramp run on the inspection form. The maximum compliant cross slope measurement is 2%.

Cross Slope 2 & 3

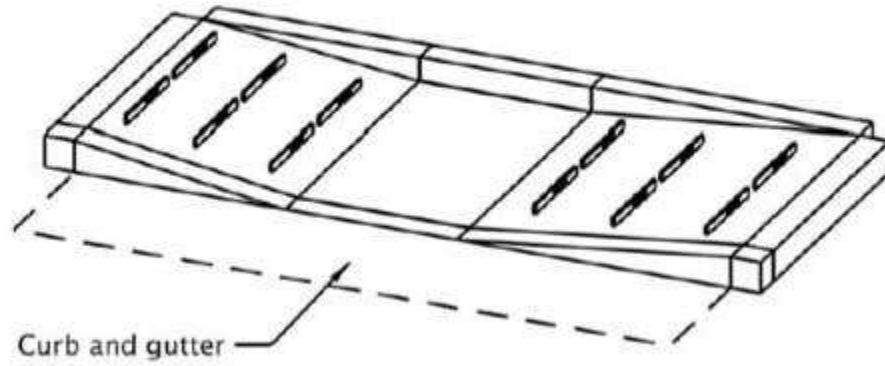

Cross Slope Measurements for Ramp Runs 2 and 3 on a Parallel Curb Ramp

Ramp Run Lengths

Run Lengths

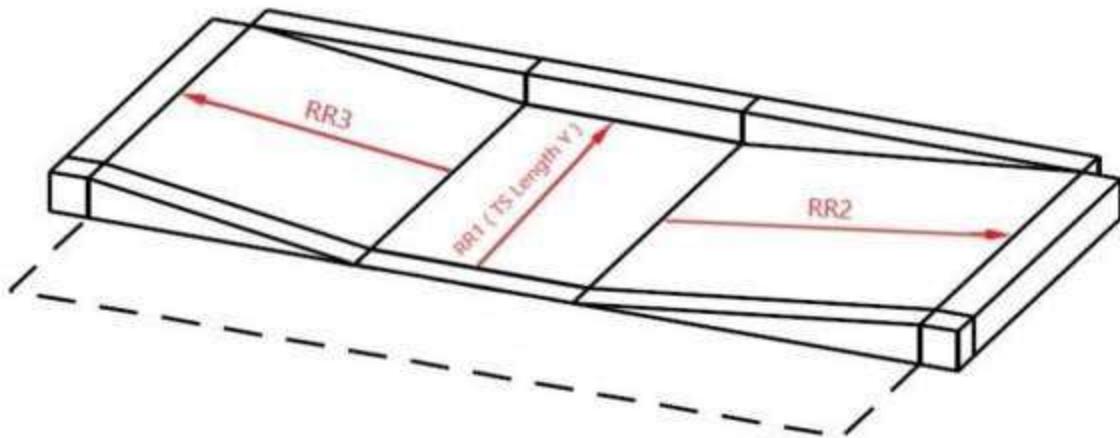

Lengths to Measure on a Parallel Curb Ramp

Measure and record the longest length of each of the ramp runs.

Parallel Curb Ramp Turn Space

In the Curb Ramp Inspection Form for Parallel Curb Ramps, Ramp Run Length 2 and 3 are recorded in the sections for Ramp Run 2 and Ramp Run 3, respectively. For Ramp Run 1, Ramp Run Length is recorded in the section for Turn Spaces, not in the Ramp Run 1 section of the form. The minimum compliant length is 4 feet. If there is a curb or other obstruction at the back of walk, the minimum length is 5 feet.

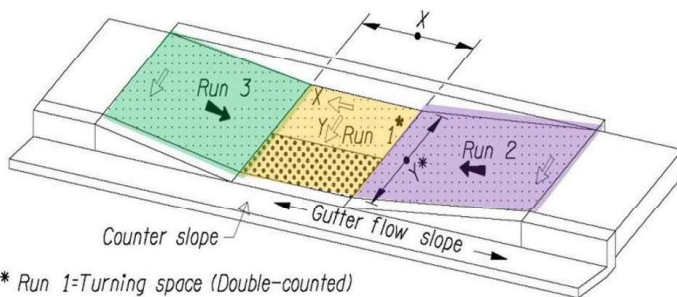

* Run 1=Turning space (Double-counted)

RAMP RUN 1		Pass	Fail	DE
Running Slope 1	<input type="text"/> ≤ 2.0% <input type="checkbox"/> > 2.0%	<input type="checkbox"/>	<input type="checkbox"/>	<input type="checkbox"/>
Cross Slope 1	<input type="text"/> ≤ 2.0% <input type="checkbox"/> > 2.0%	<input type="checkbox"/>	<input type="checkbox"/>	<input type="checkbox"/>
Detectable Warning	<input type="text"/> (TD, X) <input type="checkbox"/> (N, IITD, DMG TD)	<input type="checkbox"/>	<input type="checkbox"/>	<input type="checkbox"/>
Lip Height	<input type="text"/> 0" <input type="checkbox"/> > 0"	<input type="checkbox"/>	<input type="checkbox"/>	<input type="checkbox"/>
Gutter Flow Slope	<input type="text"/> ≤ * <input type="checkbox"/> > *	<input type="checkbox"/>	<input type="checkbox"/>	<input type="checkbox"/>
Curb Running Slope(ave)	<input type="text"/> ≤ 8.3% <input type="checkbox"/> > 8.3%	<input type="checkbox"/>	<input type="checkbox"/>	<input type="checkbox"/>
Counter Slope (+/-)	<input type="text"/> ≤ 5.0% <input type="checkbox"/> > 5.0%	<input type="checkbox"/>	<input type="checkbox"/>	<input type="checkbox"/>
RAMP RUN 2		Pass	Fail	DE
Running Slope 2	<input type="text"/> ≤ 8.3% <input type="checkbox"/> > 8.3%	<input type="checkbox"/>	<input type="checkbox"/>	<input type="checkbox"/>
Length 2	<input type="text"/>	<input type="checkbox"/>	<input type="checkbox"/>	<input type="checkbox"/>
Cross Slope 2	<input type="text"/> ≤ 2.0% <input type="checkbox"/> > 2.0%	<input type="checkbox"/>	<input type="checkbox"/>	<input type="checkbox"/>
RAMP RUN 3		Pass	Fail	DE
Running Slope 3	<input type="text"/> ≤ 8.3% <input type="checkbox"/> > 8.3%	<input type="checkbox"/>	<input type="checkbox"/>	<input type="checkbox"/>
Length 3	<input type="text"/>	<input type="checkbox"/>	<input type="checkbox"/>	<input type="checkbox"/>
Cross Slope 3	<input type="text"/> ≤ 2.0% <input type="checkbox"/> > 2.0%	<input type="checkbox"/>	<input type="checkbox"/>	<input type="checkbox"/>
TURN SPACE		Pass	Fail	DE
Width X	<input type="text"/> ≥ 4.0' <input type="checkbox"/> < 4.0'	<input type="checkbox"/>	<input type="checkbox"/>	<input type="checkbox"/>
Length Y	<input type="text"/> ≥ 4.0'* <input type="checkbox"/> < 4.0'*	<input type="checkbox"/>	<input type="checkbox"/>	<input type="checkbox"/>
Back of Ramp Obstruction (Y/N)	<input type="text"/>	<input type="checkbox"/>	<input type="checkbox"/>	<input type="checkbox"/>
Slope X (Cross Slope 1)	<input type="text"/> ≤ 2.0% <input type="checkbox"/> > 2.0%	<input type="checkbox"/>	<input type="checkbox"/>	<input type="checkbox"/>
Slope Y (Running Slope 1)	<input type="text"/> ≤ 2.0% <input type="checkbox"/> > 2.0%	<input type="checkbox"/>	<input type="checkbox"/>	<input type="checkbox"/>

Ramp Run 2 and 3 in the Curb Ramp Inspection Form for Parallel Curb Ramps.

Turn Space Dimensions

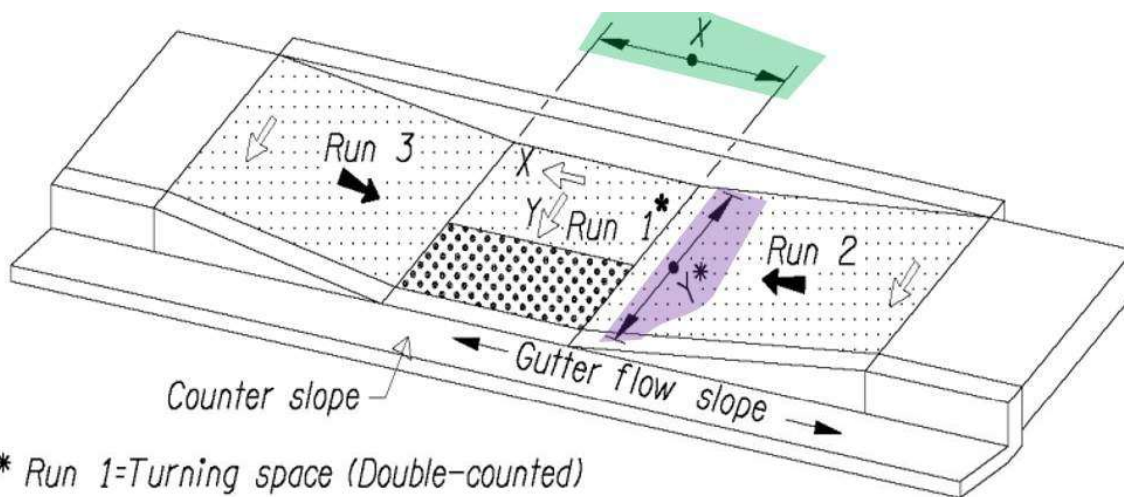

TURN SPACE		Pass	Fail	DE
Width X	<input type="text"/>	<input type="checkbox"/> $\geq 4'$	<input type="checkbox"/> $< 4'$	<input type="checkbox"/>
Length Y	<input type="text"/>	<input type="checkbox"/> $\geq 4'^*$	<input type="checkbox"/> $< 4'^*$	<input type="checkbox"/>
Back of Ramp Obstruction (Y/N)	<input type="text"/>	and	or	
Slope X (Cross Slope 1)	<input type="text"/>	<input type="checkbox"/> $\leq 2.0\%$	<input type="checkbox"/> $> 2.0\%$	<input type="checkbox"/>
Slope Y (Running Slope 1)	<input type="text"/>	<input type="checkbox"/>	<input type="checkbox"/>	<input type="checkbox"/>

Turn Space Dimensions in the Curb Ramp Inspection Form for Parallel Curb Ramps.

If the turning space has an obstruction at the back of the ramp the minimum dimensions are:

- Width X = 4.0 feet
- Length Y = 5.0 feet

Detectable Warning areas are included in the turn space measurements.

Turn Space - Slope X

The turning space slope in the X direction is the same as the Cross Slope 1 in the Ramp Run 1 section of the Inspection Form. Copy the cross slope measurement from the Ramp Run 1 Section.

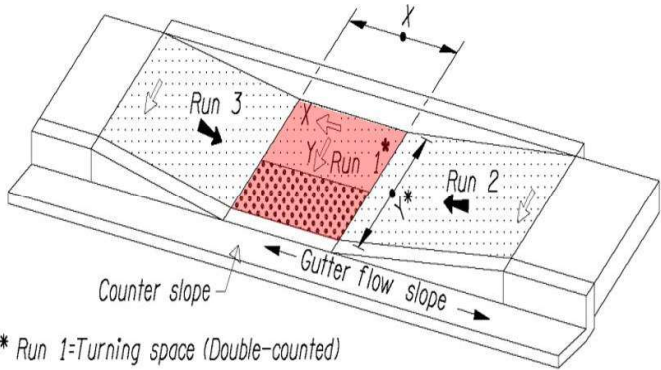

TURN SPACE		Pass	Fail	DE
Width X	<input type="text"/> $\geq 4'$	<input type="checkbox"/>	<input type="checkbox"/>	<input type="checkbox"/>
Length Y	<input type="text"/> $\geq 4'^*$	<input type="checkbox"/>	<input type="checkbox"/>	<input type="checkbox"/>
Back of Ramp Obstruction (Y/N)	<input type="text"/> and	<input type="checkbox"/>	<input type="checkbox"/>	<input type="checkbox"/>
Slope X (Cross Slope 1)	<input type="text"/> $\leq 2.0\%$	<input type="checkbox"/>	<input type="checkbox"/>	<input type="checkbox"/>
Slope Y (Running Slope 1)	<input type="text"/>	<input type="checkbox"/>	<input type="checkbox"/>	<input type="checkbox"/>

Turn Space Slope X in the Curb Ramp Inspection Form for Parallel Curb Ramps.

Turn Space - Slope Y

The turning space slope in the Y direction is the same as the Running Slope 1 in the Ramp Run 1 section of the Inspection Form. Copy the Running slope measurement from the Ramp Run 1 Section.

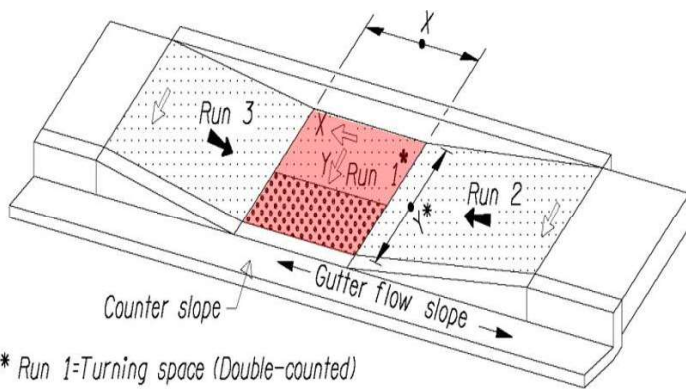

TURN SPACE		Pass	Fail	DE
Width X	<input type="text"/>	<input type="checkbox"/> $\geq 4'$	<input type="checkbox"/> $< 4'$	<input type="checkbox"/>
Length Y	<input type="text"/>	<input type="checkbox"/> $\geq 4'^*$	<input type="checkbox"/> $< 4'^*$	<input type="checkbox"/>
Back of Ramp Obstruction (Y/N)	<input type="text"/>	and	or	
Slope X (Cross Slope 1)	<input type="text"/>	<input type="checkbox"/> $\leq 2.0\%$	<input type="checkbox"/> $> 2.0\%$	<input type="checkbox"/>
Slope Y (Running Slope 1)	<input type="text"/>	<input type="checkbox"/>	<input type="checkbox"/>	<input type="checkbox"/>

Turn Space Slope Y in the Curb Ramp Inspection Form for Parallel Curb Ramps.

Detectable Warning Surfaces on a Parallel Curb Ramp

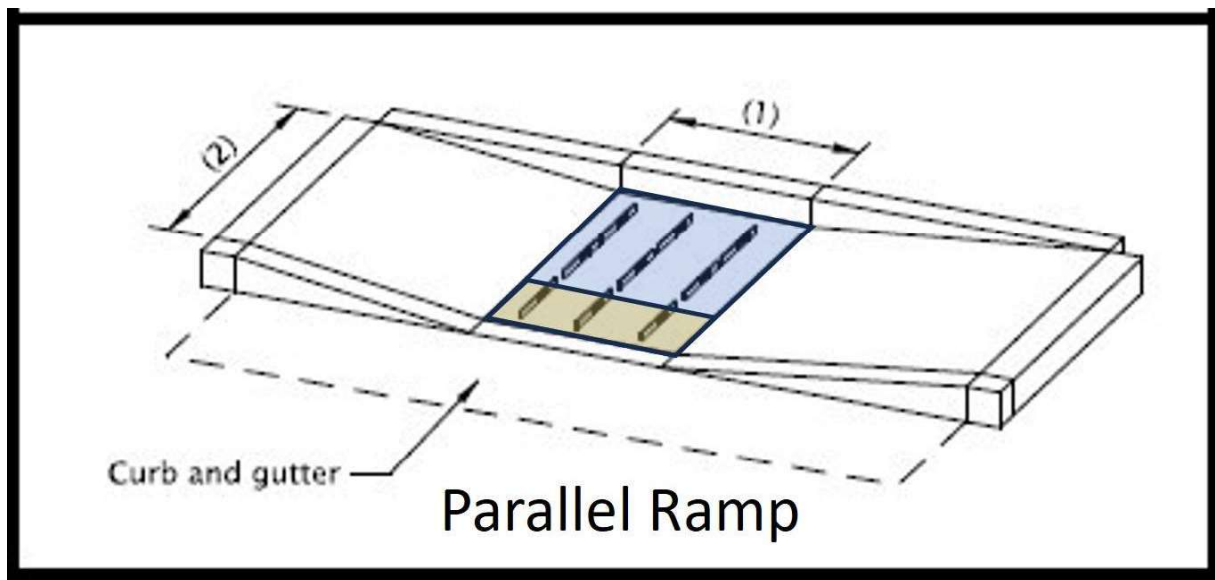

Measuring Detectable Warning Surface on a Parallel Curb Ramp

The Detectable Warning Surface (DWS) on a parallel curb ramp is on the turning space. Include the DWS in the turning space measurements.

For slope measurements on turning space, do not place the level on both concrete and DWS at the same time. Take separate measurements from each.



Review all figures and advance audio to the end before moving on.

Unit 7 Lesson 4: Combination (C) Curb Ramp Styles and Measurements



You must click on all images before moving on to next Lesson.



01:15

Start Audio Narration

Combination Curb Ramp Style

A combination curb ramp system style includes both parallel and perpendicular curb ramp system features. This is why it is called a combination ramp; it has features of both perpendicular and parallel ramps.

- It has a Ramp Run 1 and a turning space/landing at the top like a perpendicular curb ramp system.
- It has the features of the parallel curb ramp system with a Ramp Run 2 and Ramp Run 3 with running slopes touching the boundary of the turn space/landing.

Since a combination curb ramp system has a Ramp Run 1 like a perpendicular curb ramp system, the curb ramp system may have side treatments. These side treatments include flared slopes or return curb with a non-traversable surface such as landscaping. Ramp Run 1 surface may also warp to the gutter flow slope or have a directional curb component. Refer to Oregon Standard Drawings RD930 through RD939 for Combination Curb Ramp Styles. The key identification attribute of a combination curb ramp system is that the turn space is visibly at a different level than the parallel ramp runs at the turn space/landing.

Scroll through images to see different combination curb ramp examples.

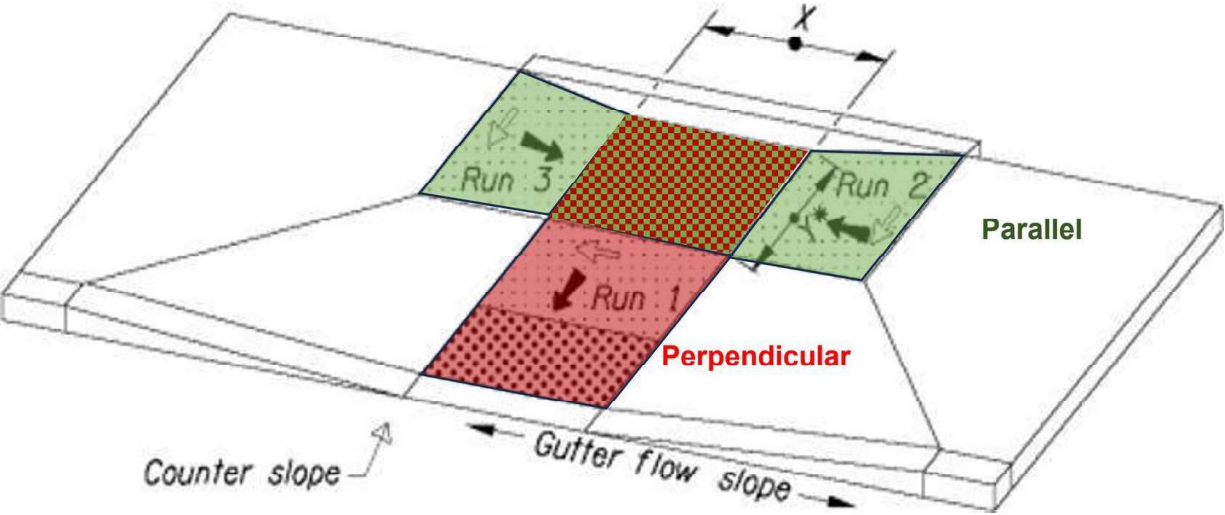

Combination Ramp has features from both Parallel and Perpendicular Ramp Styles

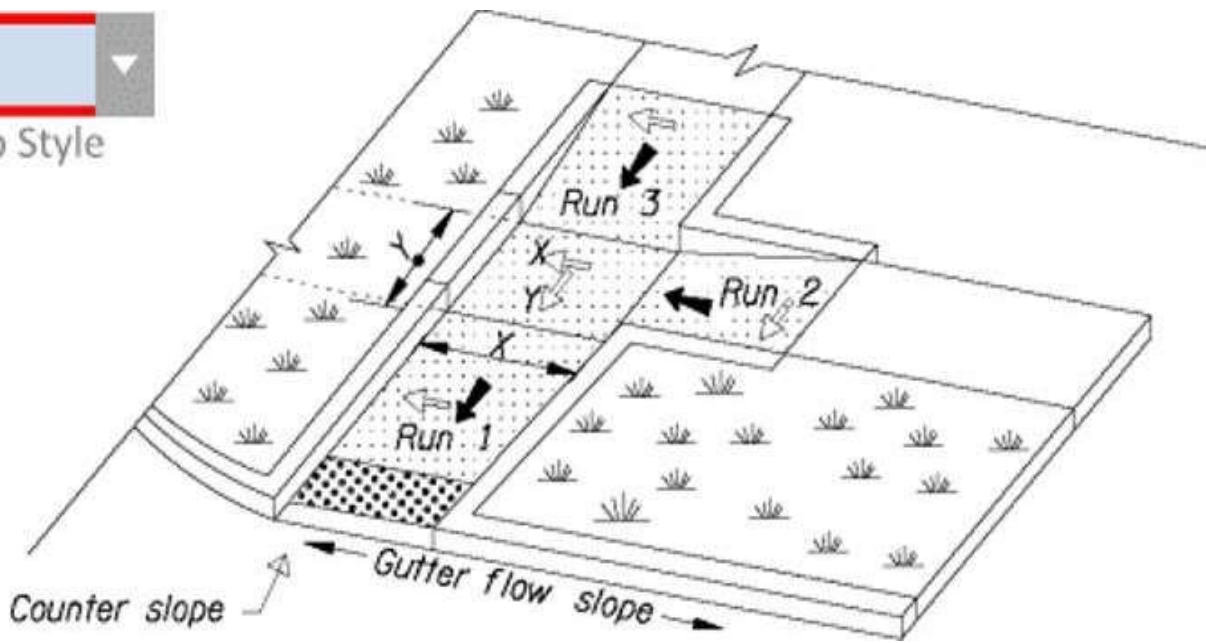

Combination Ramp Example

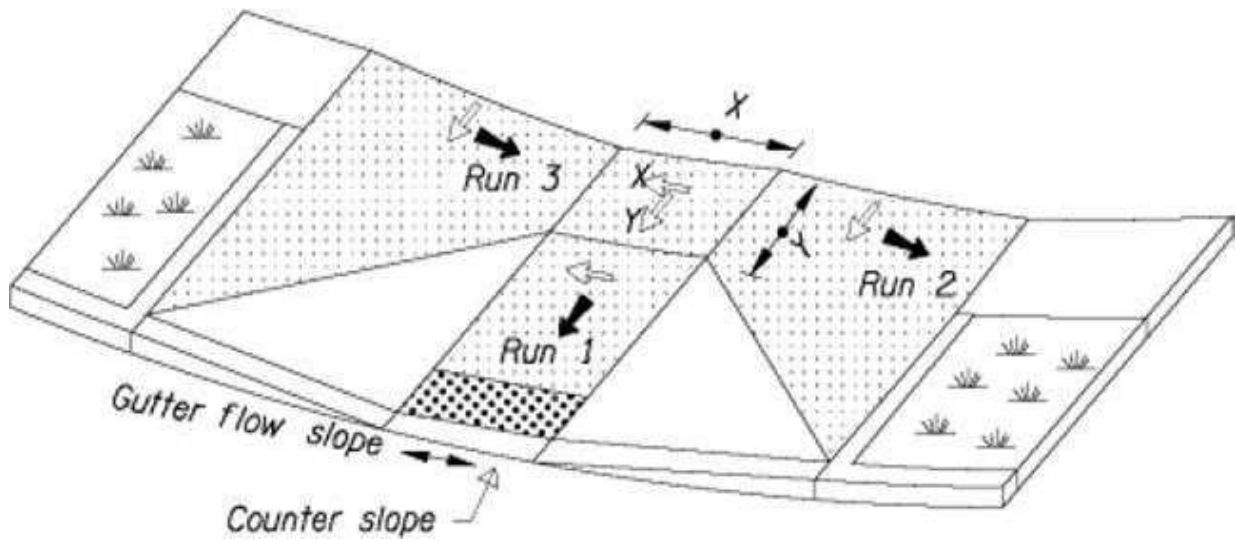

Combination Ramp Example

Combination Curb Ramp Run Numbering

Curb ramp numbering for combination curb ramp systems uses the same counterclockwise convention as parallel curb ramps systems.



Combination Curb Ramp Numbering Scheme



Combination Curb Ramp Numbering Scheme

Ramp Run Numbering with a Shared Turn Space

The figure below shows a combination curb ramp system with a shared turning space. The curb ramp system has four ramp runs indicated by a shaded red rectangular area. ODOT's abbreviation for ramp run numbers is denoted by RR#. For example, Ramp Run 1 is written as RR1.

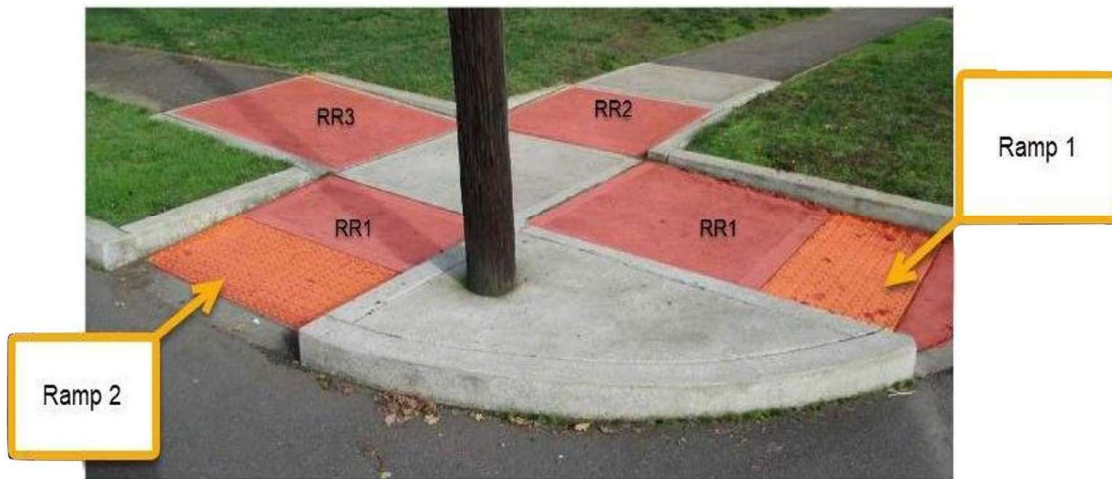

Two Combination Curb Ramps Sharing a Turn Space and Ramp Runs

Each ramp run at a corner is designated a ramp run number. Note that there are two Ramp Run 1s (RR1s); there is a RR 1 for Curb Ramp 1 System and a RR1 for Curb Ramp 2 System. Refer to image above.

With a shared turning space, the two ramps share Ramp Run 2 (RR2) and Ramp Run 3 (RR3). Ramp Run 2 and Ramp Run 3 will be the same for both curb ramp systems and recorded as such in the Curb Ramp Inspection Forms.

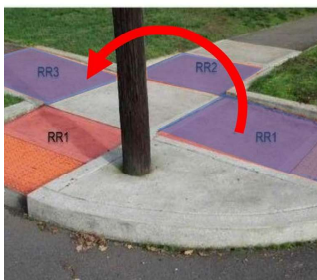

Image 1: The ramp runs for Curb Ramp

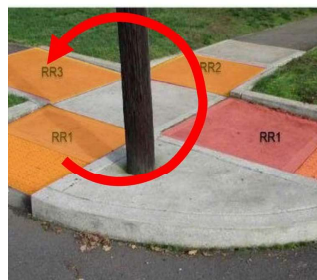

Image 2: The ramp runs for Curb Ramp

<p>1 System highlighted in purple. RR1 highlighted in red is part of Curb Ramp 2 System and not part of Curb Ramp 1 system. Note the counterclockwise numbering of the ramps.</p>	<p>2 System in yellow. Note that RR1 of Curb Ramp 1 system is not included since this is not a ramp run for the Curb Ramp 2 system. Each curb ramp system is also numbered counterclockwise.</p>
---	--

Combination Curb Ramp System Measurements

Ramp Run Slopes

Ramp Run 1 follows the same slope measurements as Ramp Run 1 on a perpendicular curb ramp system. This includes recording the cross slope at the top of Ramp Run 1 and warping to the gutter flow slope. The maximum compliant cross slope at the top of Ramp Run 1 is 2.0%. Cross slope measurements on the ramp run surface cannot be greater than the maximum gutter flow slope based on the intersection control type.

When there is a directional curb, the maximum compliant cross slope of the directional curb is based on the intersection control type. The maximum compliant running slope of the directional curb is 4.9%.

Ramp Runs 2 and 3 follow the same slope measuring rules as on a parallel curb ramp. The maximum compliant running slope is 8.3% and a cross slope of 2.0%.

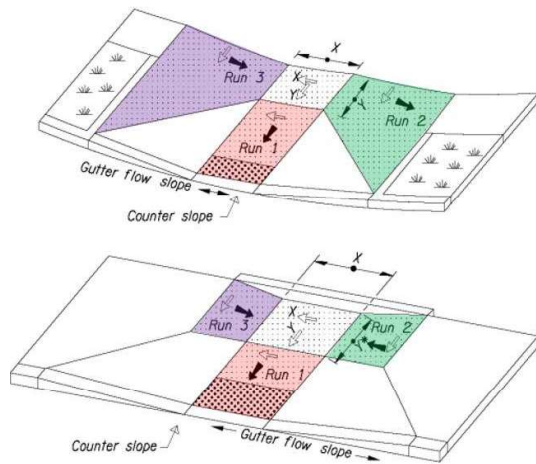

RAMP RUN 1		Pass	Fail	DE
Running Slope 1	<input type="text"/> ≤ 8.3% <input type="checkbox"/> > 8.3% <input type="checkbox"/>	<input type="checkbox"/>	<input type="checkbox"/>	<input type="checkbox"/>
Length 1	<input type="text"/>	<input type="checkbox"/>	<input type="checkbox"/>	<input type="checkbox"/>
Cross Slope 1	<input type="text"/> ≤ 2.0% <input type="checkbox"/> > 2.0% <input type="checkbox"/>	<input type="checkbox"/>	<input type="checkbox"/>	<input type="checkbox"/>
Detectable Warning	<input type="text"/> (TD, X) <input type="checkbox"/> (N, ITD, DMG TD) <input type="checkbox"/>	<input type="checkbox"/>	<input type="checkbox"/>	<input type="checkbox"/>
Lip Height	<input type="text"/> 0" <input type="checkbox"/> > 0" <input type="checkbox"/>	<input type="checkbox"/>	<input type="checkbox"/>	<input type="checkbox"/>
Gutter Flow Slope	<input type="text"/> ≤ * <input type="checkbox"/> > * <input type="checkbox"/>	<input type="checkbox"/>	<input type="checkbox"/>	<input type="checkbox"/>
Curb Running Slope (avg)	<input type="text"/> ≤ 8.3% <input type="checkbox"/> > 8.3% <input type="checkbox"/>	<input type="checkbox"/>	<input type="checkbox"/>	<input type="checkbox"/>
Counter Slope (+/-)	<input type="text"/> ≤ 5.0% <input type="checkbox"/> > 5.0% <input type="checkbox"/>	<input type="checkbox"/>	<input type="checkbox"/>	<input type="checkbox"/>
RAMP RUN 2		Pass	Fail	DE
Running Slope 2	<input type="text"/> ≤ 8.3% <input type="checkbox"/> > 8.3% <input type="checkbox"/>	<input type="checkbox"/>	<input type="checkbox"/>	<input type="checkbox"/>
Length 2	<input type="text"/>	<input type="checkbox"/>	<input type="checkbox"/>	<input type="checkbox"/>
Cross Slope 2	<input type="text"/> ≤ 2.0% <input type="checkbox"/> > 2.0% <input type="checkbox"/>	<input type="checkbox"/>	<input type="checkbox"/>	<input type="checkbox"/>
RAMP RUN 3		Pass	Fail	DE
Running Slope 3	<input type="text"/> ≤ 8.3% <input type="checkbox"/> > 8.3% <input type="checkbox"/>	<input type="checkbox"/>	<input type="checkbox"/>	<input type="checkbox"/>
Length 3	<input type="text"/>	<input type="checkbox"/>	<input type="checkbox"/>	<input type="checkbox"/>
Cross Slope 3	<input type="text"/> ≤ 2.0% <input type="checkbox"/> > 2.0% <input type="checkbox"/>	<input type="checkbox"/>	<input type="checkbox"/>	<input type="checkbox"/>

Ramp Runs on a Curb Ramp Inspection Form for Combination Curb Ramps



02:48

Continue Audio Narration

Ramp Run Lengths and Grade Breaks

Record the longest Ramp Run length for all ramp runs. Remember, if there is a directional curb, the measurement length of Ramp Run 1 includes the directional curb. As with all ramp runs, a grade break perpendicular to the ramp running slope is required at the top and bottom of all ramp runs.

Detectable Warning Surfaces

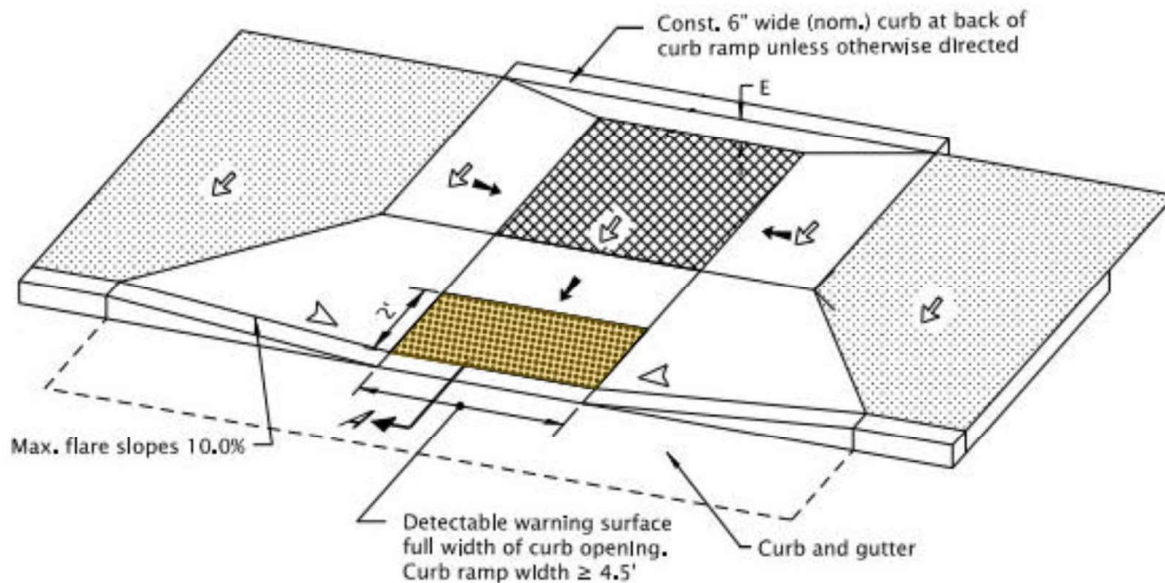

Detectable Warning Surface on a Combination Ramp

Detectable Warning surfaces are installed the same as they are on Perpendicular Curb Ramps. The detectable warning surface shall extend the full width of the curb ramp opening or other roadway entrance as applicable. A gap of up to 2 inches on each side of the detectable warning surface is permitted.

If a directional curb is used, follow the guidance for detectable warning surface placement as described in Unit 5 on directional Curbs and on detectable warnings on directional curbs.

Turn Spaces

The turn space on a combination curb ramp follows the same measurements as on a perpendicular curb ramp.

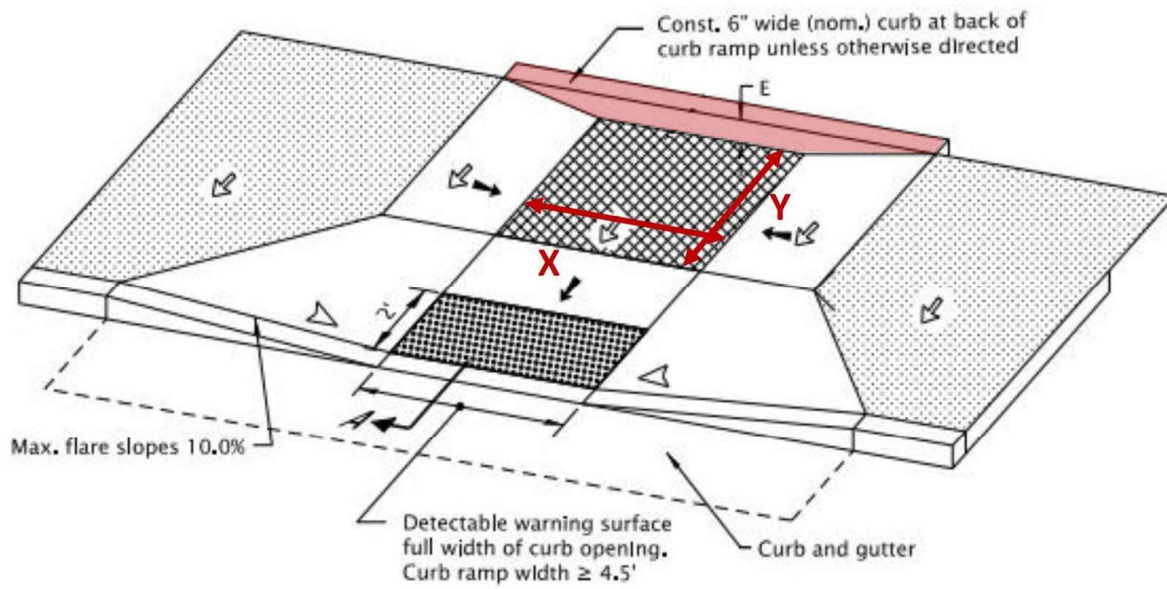

Turning Space on a Combination Curb Ramp



Measuring Slopes in the X Direction on a Combination Curb Ramp

Landing Slope X

Take measurements of the turn space in the X direction placing the 2-foot smart level perpendicular to the Ramp Run 1 Running Slope at a minimum of 1-foot increments. Record the greatest slope measurement to the tenth of a percent. The maximum allowable slope is 2%.

Landing Width X

Record the narrowest width found to the tenth of a foot. The minimum allowable width is 4 feet. Comment if there is an object, such as a pedestrian pole, on the turn space.



Measuring Slopes in the Y Direction on a Combination Curb Ramp

Landing Slope Y

Take measurements of the turn space in the Y direction placing the 2-foot smart level parallel to the Ramp Run 1 Running Slope at a minimum of 1-foot increments. Record the greatest slope

measurement to the tenth of a percent. The maximum allowable slope is 2%.

Landing Length Y

Record the shortest length of the turn space to a tenth of a foot. The minimum allowable width is 4 feet. If there is an obstruction at the back of walk, the minimum allowable length is 5 feet. Refer to Unit 5. Comment if there is an object, such as a pedestrian pole on the turn space.

Shared Turn Spaces

Some corner curb ramp designs have two combination curb ramps sharing a turn space. Refer to Shared Turning Spaces in Unit 5 for guidance on how to measure a shared turn space for each ramp. The maximum allowable cross slope in the x and y directions is 2.0%.

Flares

Flares are common on combination curb ramps.

Measurements are taken parallel to the curb line from the back of curb and no farther back than one foot back. Flare slopes are not to be greater than 10%.

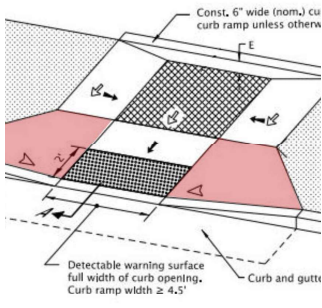

*Flares on a
Combination Curb
Ramp*

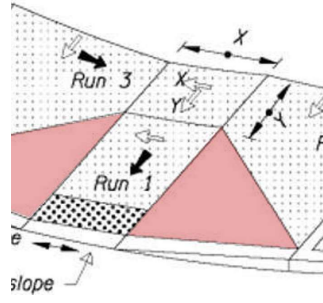

*Flares on a
Combination Curb
Ramp*

 Review all figures and advance audio to the end before moving on.

CONTINUE

Unit 7 Lesson 5: Cut Through Island (CT) Curb Ramp Style and Measurement



You must click on all images before moving on to next Lesson.



01:53

Start Audio Narration





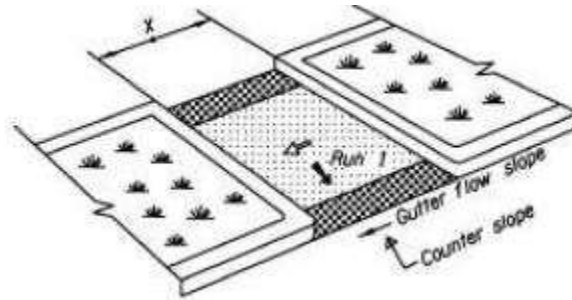

Cut Through Island (CT) Curb Ramp Style

A cut through island is usually a median island or a turn lane channelization island that is depressed at the roadway pavement grade, providing a protected pedestrian access route space in the crosswalk.

Some cut through island styles maintain and utilize the existing street asphalt surface as the pedestrian access route. Some cut through island styles utilize constructed concrete as the pedestrian access route surface. Constructing the pedestrian access route with concrete is typically used when a level landing or turn space is needed within the interior of the cut through island.



CUT THROUGH (CT)

-  Pedestrian access route (To measure clear width)
-  Detectable warning surface
-  Cross slope
-  Running slope
-  Counter slope (5.0% finish grade max.)
-  Gutter flow slope (as required)

Cut Through Island

Cross slope and **gutter flow slope** acceptance criteria are determined based on **turn space needs, intersection condition type, and adjacent slope of road**. The minimum passing clear width dimension on a cut through island is 5.0 feet.

Refer to Oregon Standard Drawing RD710, Accessible Route Islands and RD711, Accessible Route Channelized Islands. Review Oregon Standard Drawing RD906, Detectable Warning Surface Placement for Accessible Route Islands for installation requirements.



RD710.pdf
372.8 KB





RD711.pdf
328.4 KB



RD906.pdf
215.6 KB





A Midblock Cut Through Island

Note: **Not all island locations have cut throughs.** Island locations may have a perpendicular curb ramps system to continue along the crosswalk. Use perpendicular curb ramp inspection

forms for this scenario.



Island with Perpendicular Curb Ramp Systems



03:25

Continue Audio Narration

Measurements on Ramp Runs in Cut Through Islands

Running Slopes

There are three different scenarios for measuring cut through islands curb ramp systems. Refer to image below.

1. Where a cut through island has a turn space or level landing, measure the ramp running slope from the turn space or level landing boundary to the back of curb for each ramp run position.
2. Where a median island has no level landing, measure the entire cut through route, noting whether there are opposing slopes, such as a crown in the road.
3. Measure from the grade break, typically midpoint for a crowned roadway of the cut through to the back of curb. Record the maximum running slope value. Each curb ramp opening will have its own inspection form for the curb ramp system at the cut through island.

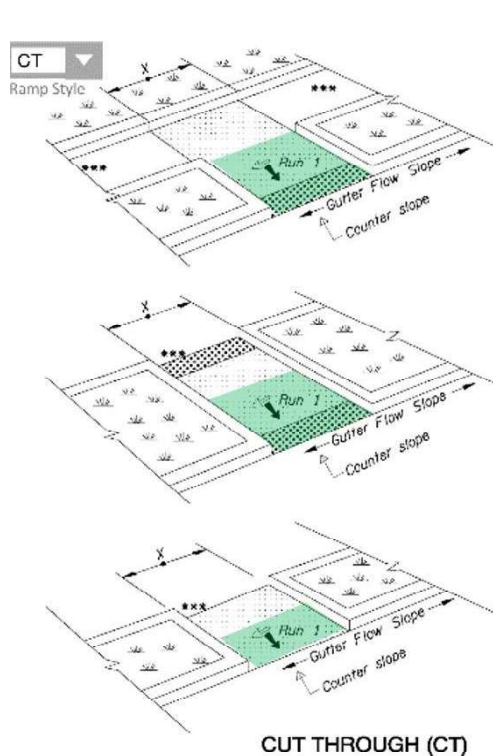

RAMP RUN 1		Pass	Fail	DE
Running Slope 1	<input type="text"/> ≤ 8.3%	<input type="checkbox"/> >8.3	<input type="checkbox"/>	<input type="checkbox"/>
Cross Slope 1	<input type="text"/> ≤ *	<input type="checkbox"/> >*	<input type="checkbox"/>	<input type="checkbox"/>
Detectable Warning	<input type="text"/> (TD, X)	<input type="checkbox"/> (N, IITD, DMG TD)	<input type="checkbox"/>	<input type="checkbox"/>
Lip Height	<input type="text"/> 0"	<input type="checkbox"/> > 0"	<input type="checkbox"/>	<input type="checkbox"/>
Gutter Flow Slope	<input type="text"/> ≤ *	<input type="checkbox"/> > *	<input type="checkbox"/>	<input type="checkbox"/>
Curb Running Slope(avg) <input type="checkbox"/> N/A	<input type="text"/> ≤ *1	<input type="checkbox"/> > *1	<input type="checkbox"/>	<input type="checkbox"/>
Counter Slope (+/-)	<input type="text"/> ≤ 5.0%	<input type="checkbox"/> > 5.0%	<input type="checkbox"/>	<input type="checkbox"/>

Image of Running Slope 1 in the Curb Ramp Inspection Form for Cut

Through Islands

Turn Space

Turn spaces are required on cut through islands that require turning movements to navigate through each crosswalk on the pedestrian access routes. The width and length of the turn space area must be a minimum of 5.0 feet for each curb ramp opening. The slopes in the X and Y directions are a maximum of 2.0%.



A Cut Through with a through movement that may or may not require a Turn Space depending on Running Slopes

A "pork chop" style Cut Through Island that requires a Turn Space

Detectable Warning Surface (DWS) at Cut Through Islands

- Detectable warning surface (DWS) is referred to in the inspection forms as Truncated Domes (TD).
- There must be at least two feet between detectable warning surfaces on a cut through island.

- Where the cut through island is less than 6 feet wide, there should be no detectable warning surface.
- Where detectable warning surfaces are correctly omitted from the curb ramp system, mark X for exempt on the inspection form.
- Where there is curb and gutter on the island, detectable warning surface placement is at back of curb.
- Where there is no curbing at the island, detectable warning surface placement is flush with the opening at the curb face.
- Where detectable warning surface are present but should have been omitted, mark that they are incorrectly installed truncated domes (IITD).

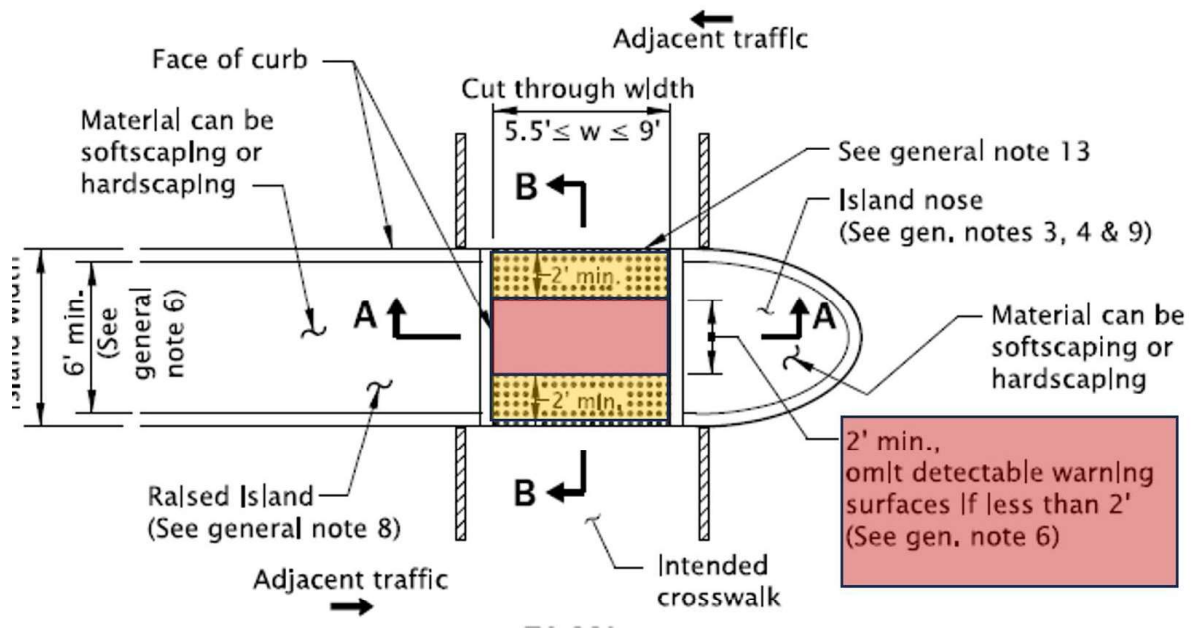
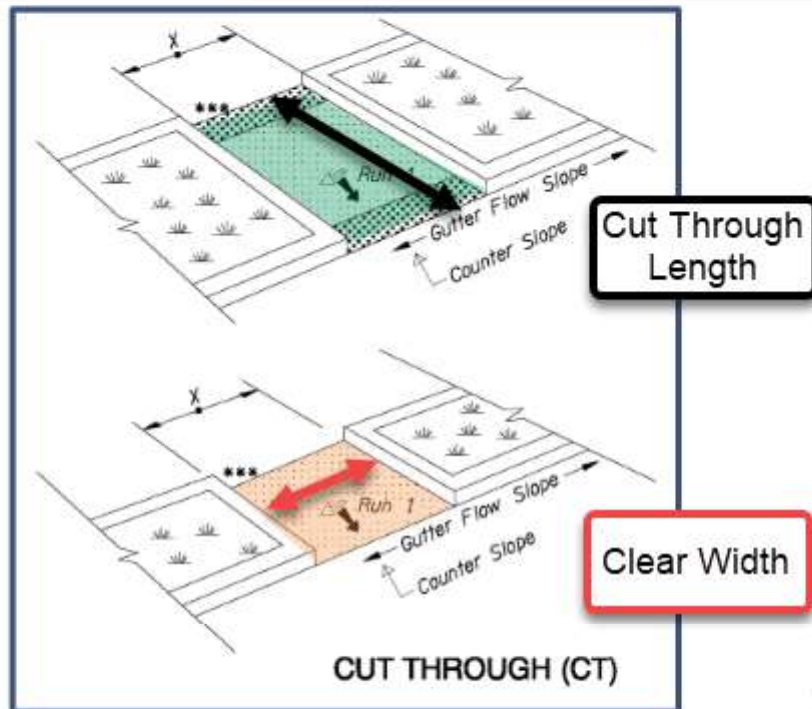

Illustration of Cut Through Island Highlighting the Placement of DWS on an Island.

If a space that is at least two feet wide between the DWS is not possible, omit the DWS.

- i** If a turning maneuver is required to navigate the cut through island, a turn space must be measured and recorded. Measure turn spaces in the same manner as other ramp types.

MISCELLANEOUS	Traversable	Pass	Fail	DE
Flare Slope 1	<input type="checkbox"/>	<input type="checkbox"/> ≤ 10%	<input type="checkbox"/> > 10%	<input type="checkbox"/>
Flare Slope 2	<input type="checkbox"/>	<input type="checkbox"/> ≤ 10%	<input type="checkbox"/> > 10%	<input type="checkbox"/>
Clear Width (feet)	<input type="checkbox"/>	<input type="checkbox"/> ≥ 5.0'	<input type="checkbox"/> < 5.0'	<input type="checkbox"/>
Intersection Condition Type	<input type="text"/>			
Slope of Road	<input type="text"/>			
Cut Through Length ≥ 6 FT (Y/N)	<input type="text"/>			
Design Ex. Control Number	<input type="text"/>			



Clear Width and Length on a Curb Ramp Inspection Form for Cut Through Island.

Clear Width

Clear width is depicted as the X dimension on the graphic from face of curb to face of curb. Record the smallest width in the Curb Ramp Inspection Form. The minimum accessible clear width is 5 feet wide.

Length of Cut Through

Cut through length is measured from one curb line to the other. In the Curb Ramp Inspection Form for Cut Through Islands, it is only pertinent to know if it is less than or greater than 6 feet.

- Where cut through length is 6.0 feet or greater record “Y”.
- Where cut through length is less than 6.0 feet record “N”.



Review all figures and advance audio to the end before moving on.

CONTINUE

Unit 7 Lesson 6: End of Walk (EW) Curb Ramp Style and Measurement



You must click on all images before moving on to next Lesson.



03:08

Start Audio Narration

Ramp Style: End of Walk

An end of walk curb ramp style is the transition from sidewalk to roadway shoulder. Refer to Oregon Standard Drawings RD950 and RD952. The End of Walk Curb Ramp style was developed to transition to roadways where the sidewalk stops and the roadway curb stops collecting roadway storm water.

End-of-Walk

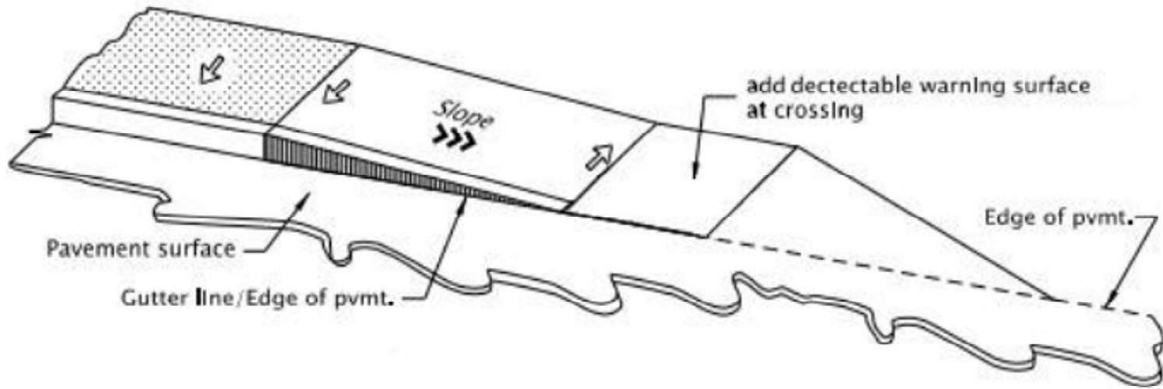

End of Walk Standard Drawing Illustration



RD950.pdf
402.2 KB



RD952.pdf
365.6 KB



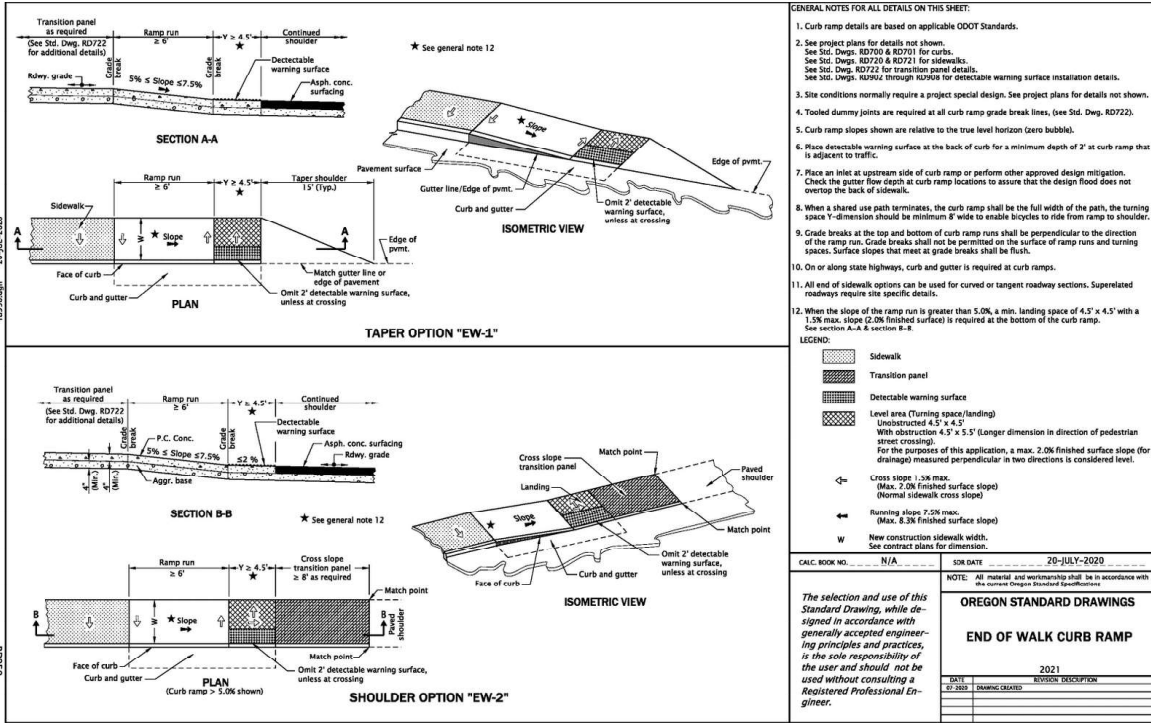

Effective Date: December 1, 2020 – May 31, 2021

RD950

RD950 End of Walk Curb Ramp Standard Drawing

End of Walk Ramp Run 1

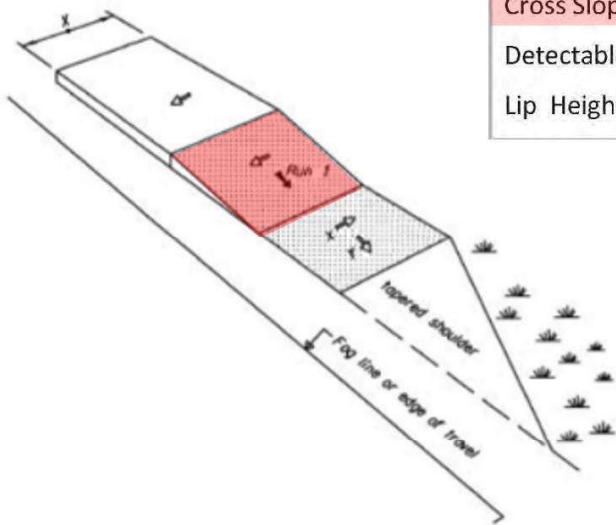

RAMP RUN 1		Pass	Fail	DE
Running Slope 1	<input type="text"/> ≤ 8.3%	<input type="checkbox"/> > 8.3%	<input type="checkbox"/>	<input type="checkbox"/>
Length 1	<input type="text"/>			
Cross Slope 1	<input type="text"/> ≤ 2.0%	<input type="checkbox"/> > 2.0%	<input type="checkbox"/>	<input type="checkbox"/>
Detectable Warning	<input type="text"/>			
Lip Height	<input type="text"/> 0"	<input type="checkbox"/> > 0"	<input type="checkbox"/>	<input type="checkbox"/>

End of Walk Ramp from the Curb Ramp Inspection Form with Ramp Run 1 Highlighted.

Running Slope 1

Record the maximum running slope. The maximum running slope is 8.3%.

Length 1

Record the maximum length of the ramp run.

Cross slope 1

End of walk ramps, the cross slope must be measured all the way down and the highest measurement recorded.

End of Walk Style Turn Space or Landing Need

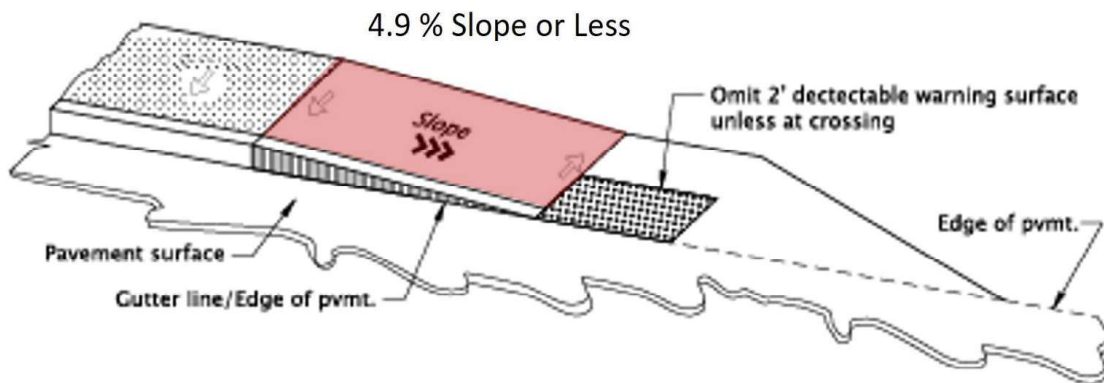

Illustration of End of Walk Ramp. A Landing at the Bottom of the Ramp is Only Required When the Ramp Run Slope Exceeds 4.9%. Omit DWS if there is not a pedestrian Crossing.

A turn space is required at the bottom of ramp run when a pedestrian with a mobility device needs to turn to maneuver onto shoulder to proceed along the roadway. Mark the applicable box. A landing is required when the ramp run slope exceeds 4.9%. Mark "Neither" on the inspection form if the Running Slope 1 on Ramp Run 1 is less than or equal to 4.9% AND a turning movement is not required. See RD950 and RD952 for additional details.



End of Walk Curb Ramp that Requires



End of Walk Curb Ramp that Does Not

a Turn Space for Pedestrians to Navigate out to Shoulder.

Require a Turn Space Since Pedestrians Can Navigate to Shoulder Without a Turning Maneuver.

Where a turn space is required, provide the Turn Space area slopes and dimensions. Note: The X and Y orientation is not the same as a parallel curb ramp system.

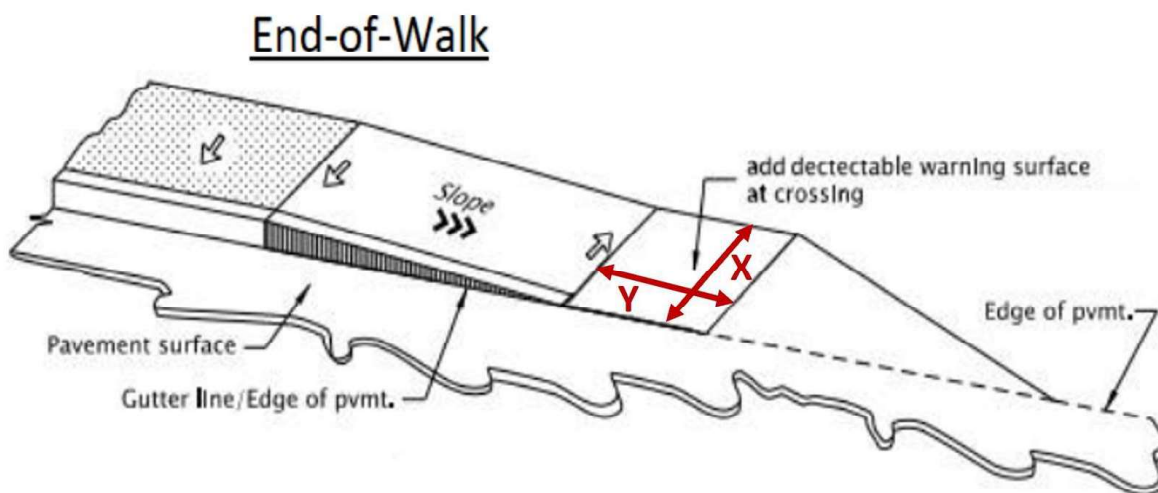

End of Walk Turn Space with X and Y Orientation.

Detectable Warning Surface (Truncated Domes (TD))

Detectable Warning Surface (Truncated Domes (TD)) are omitted when the end of walk style is not located at street crossing.

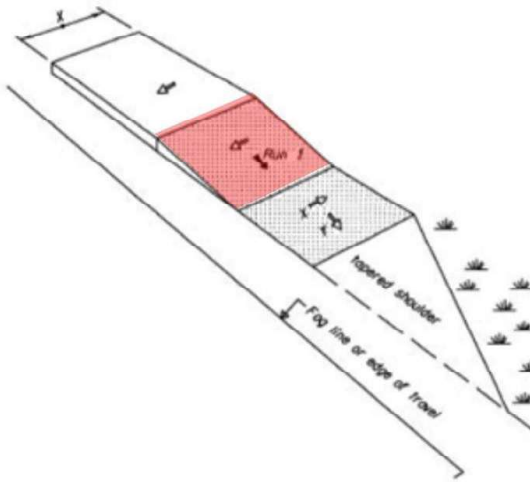

RAMP RUN 1		Pass	Fail	DE
Running Slope 1	<input type="text"/> ≤ 8.3% <input type="checkbox"/> > 8.3%	<input type="checkbox"/>	<input type="checkbox"/>	<input type="checkbox"/>
Length 1	<input type="text"/>			
Cross Slope 1	<input type="text"/> ≤ 2.0% <input type="checkbox"/> > 2.0%	<input type="checkbox"/>	<input type="checkbox"/>	<input type="checkbox"/>
Detectable Warning	<input type="text"/>			
Lip Height	<input type="text"/> 0" <input type="checkbox"/> > 0"	<input type="checkbox"/>	<input type="checkbox"/>	<input type="checkbox"/>

Entries in the End of Walk Curb Ramp Inspection Form for Detectable Warnings and Lip Height

i Counter Slope and Gutter Flow Slope at End of Walk Locations.

Counter slope and gutter flow slope are not applicable measurements for end of walk curb ramp locations.

i Where end of walk curb ramp systems are located at a street intersection, corners use the Unique Curb Ramp Form for inspection.



Review all figures and advance audio to the end before moving on.

CONTINUE

Unit 7 Lesson 7: Blended Transition (BT) Curb Ramp Style and Measurement



You must click on all images before moving on to next Lesson.



02:55

Start Audio Narration





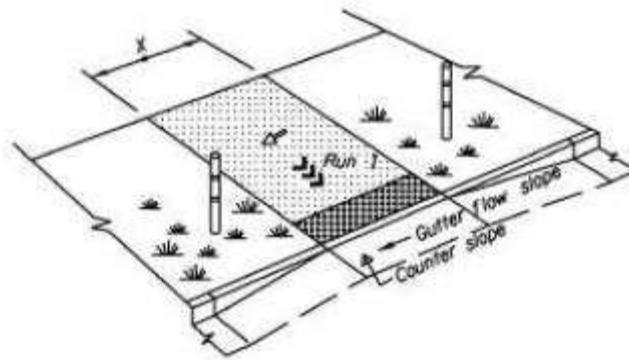

Ramp Style: Blended Transition (BT)

The blended transition curb ramp system style has no level area or turn space measurement. The path of travel on the pedestrian access route does not require a change in direction and the running slope of the connection to the roadway is less than or equal to 4.9%.

This style is commonly used on shared use paths connections to the roadway, but it could apply to other types of intersection corners.



BLENDING TRANSITION (BT)

-  Pedestrian access route (To measure clear width)
-  Detectable warning surface
-  Cross slope (2.0% finish grade max.)
-  Running slope (<5.0% finish grade max.)
(If running slope $\geq 5.0\%$, this is a curb ramp, not a blended transition.)
-  Counter slope (5.0% finish grade max.)
-  Gutter flow slope (as required)
-  Edge of Gutter Pan

Blended Transition

Engineering for Accessibility Website: Blended Transition Inspection Form

BLENDED TRANSITION

The blended transition inspection form is ONLY USED when the running slope for Ramp Run 1 is LESS THAN OR EQUAL TO 4.9% and there is NO TURN SPACE.



Note: When a level area or landing is present, use the perpendicular curb ramp inspection form.

Running Slope

Requires a maximum running slope equal to or less than 4.9%.

Cross Slope and Gutter Flow Slope

The passing measurement for Cross Slope 1 (CS1) and gutter flow slope (GFS) depends on the intersection condition type.

Cross Slope 1 follows the listed rules.

- At a midblock crossing, Cross Slope 1 must be less than or equal to the slope of the road,
- At Signalized or Uncontrolled (SU), Cross Slope 1 must be less than or equal to 5.0%,
- At Stop or Yield (SY), Cross Slope 1 must be less than or equal to 2.0%.

Directional Curbs

Blended transition curb ramp styles will not typically have a separate directional curb component.

The directional curb component is constructed to create a perpendicular grade break for ramp run 1.

Pedestrian Lanes

Pedestrian facilities that are constructed at-grade and flush with the adjacent road surface with a physical separation from traffic are called pedestrian lanes (often resembling a shoulder). A

photograph of an example pedestrian lane is shown below. There is not a curb present at the crosswalk. The crosswalk, in this case, starts at the end of the detectable warning surface. Pedestrian lanes are a part of the pedestrian access route and are captured on a curb ramp inspection form for asset purposes because it serves the crosswalk and must be ADA accessible. **This type of design will be inspected as a Blended Transition Curb Ramp Form.**



Pedestrian Lane Example



Pedestrian Lane Example

Do not inspect this as an End of Walk Curb Ramp Style as the walkway is largely following the roadway grade for its entirety. This type of facility may be located at an end of walk location, which would be reflected in the cross street name data field.



Review all figures and advance audio to the end before moving on.

CONTINUE

Unit 7 Lesson 8: Unique Design (UD) Curb Ramp Style and Measurement



You must click on all images before moving on to next Lesson.



05:49

Start Audio Narration

Ramp Style: Unique Design

This is a ramp with a design that does not fall into the previously described ramp types. A common type of unique design ramp is one that looks similar to a parallel or combination ramp missing Ramp Run 2 or 3 or both.

The passing value for gutter flow slope and directional curb slope on a unique design curb ramp depends on the intersection condition type.

- At a midblock (MB) crossing, slopes must be less than or equal to the Slope of the Road
- At Signalized or Uncontrolled (SU) crossings, slopes must be less than or equal to 5.0%
- At Stop or Yield (SY) crossing, slopes must be less than or equal to 2.0%.

- Refer to Standard Drawings to assess provisions not shown such as inlets, alignment, etc.



*A One-Sided Parallel Ramp is Considered a Unique Design Style
Curb Ramp*

Pedestrian Pads at Signalized Intersections

Rural intersections are often signalized without an exclusive pedestrian sidewalk or walkway. In some cases, an added pedestrian feature is constructed outside the normal roadway shoulder called a pedestrian pad (constructed of asphalt or concrete).

A level area/clear space that is constructed to provide accessible access to a pedestrian pushbutton with detectable warning surfaces behind the shoulder (edge of the vehicular travelway) is a type of pedestrian pad. An example is at a rural RRFB marked crosswalk.



Concrete Pedestrian Pad to Access Pushbutton

Pedestrian Pads are typically level areas that are constructed to provide accessible access to a pedestrian feature such as a pedestrian push button at a rural signalized intersection. The pushbutton activation must still be accessible meeting the reach, range and landing requirements which is captured on the pushbutton inspection form.

A curb ramp inspection form is completed based on the construction features in addition to the pushbutton inspection form. The same geometric requirements for curb ramps including but not limited to running slope, cross slope, counter slope, level areas, and installation of detectable warning surfaces are utilized. **Utilize the Unique Curb Ramp Inspection Form to inspect this pedestrian pad surface.**



*Paved Shoulder Pushbutton Clear Space, No Curb Ramp System
Constructed*

When a pedestrian signal is present at the intersection and the pedestrian clear space overlaps the normal shoulder surface, it is inspected with a Pedestrian Pushbutton Inspection Form A. Measure the slopes and dimensions of the Clear Space.

Depressed Curb Ramps One-Sided

This term refers to a curb ramp design where the turn space/landing area is fully lowered at the intersection. It has one ramp run and is curb tight at the corner of an intersection. This resembles the layout illustrated in Oregon Standard Drawing RD922, Option PL-4 however, it has only one sidewalk approach (see below).

This style of curb ramp is recorded on the Unique Curb Ramp Inspection form, usually accompanied by a Design Exception.

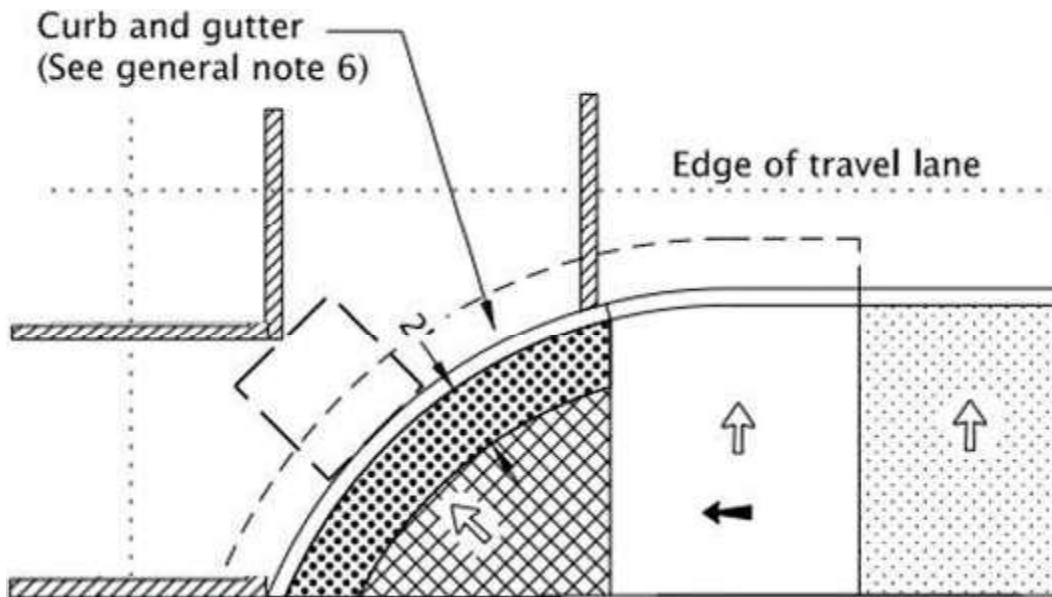

A Depressed Curb Ramp, One Sided.

This curb ramp design puts pedestrians directly adjacent to traffic without the benefit and protection of a raised curb on the radius. The fully lowered portion of the curb ramp is open, and level and allows pedestrians to enter and exit the curb ramp from either direction at the intersection. This style of curb ramp can serve both crosswalks at the intersection in some cases. **A design exception is usually required to construct this style of curb ramp if it serves two crossings.**

The detectable warning surface is required to extend at least 2 feet deep in the direction of pedestrian travel across the entire full width of the curb ramp. These types of curb ramps frequently have a portion where the detectable warning surface requirement is not met. The section immediately adjacent to the curb line is where this failure occurs. Refer to the following images. For this reason, **an approved curb ramp design exception for criteria R often accompanies these types of curb ramps.**

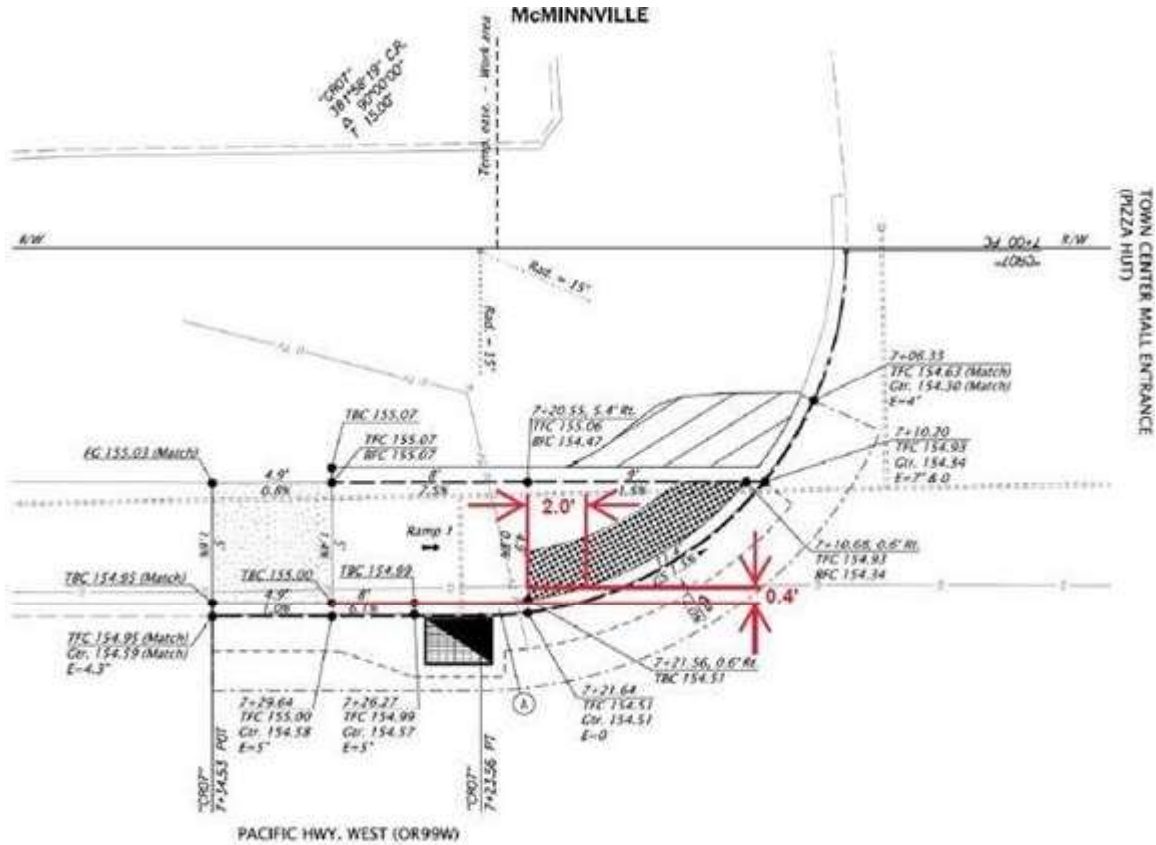

Image Illustrating Where There is Not at Least 2 Feet of DWS Surface In the Direction of Travel

Measurements for the Depressed Curb Ramps One-Sided

Measuring Slopes:

It is important to measure Depressed Curb Ramps One-Sided Turn Spaces (landing area) in a consistent manner. The X and Y direction slopes for the Turn Spaces (landing area) on these ramps will always be parallel and perpendicular to the primary roadway.

What determines the direction of the X and Y slopes is the ODOT highway location to the curb ramp. When both roadways are ODOT highways, the lower numbered highway becomes the primary roadway.

If the curb ramp is part of a jurisdictional transfer, the curb ramp will be given a new highway number and given an "A" overlapping mileage code. Contact the ODOT Statewide Asset Specialist in the resource material for this and other unique situations.

For local agency roads, use the road with the higher functional class or possibly whichever road is parallel to an ODOT highway as the primary roadway, following a similar convention to that above. If questions arise about off-system intersections, contact the ODOT Statewide Asset Specialist.

The Y axis is oriented in the same direction as the crossing for the ODOT Mainline or higher functional class same direction as the crossing for the ODOT Mainline or higher functional class roadway (the primary roadway), while **the X axis (Cross Slope) is perpendicular to the mainline crossing.**

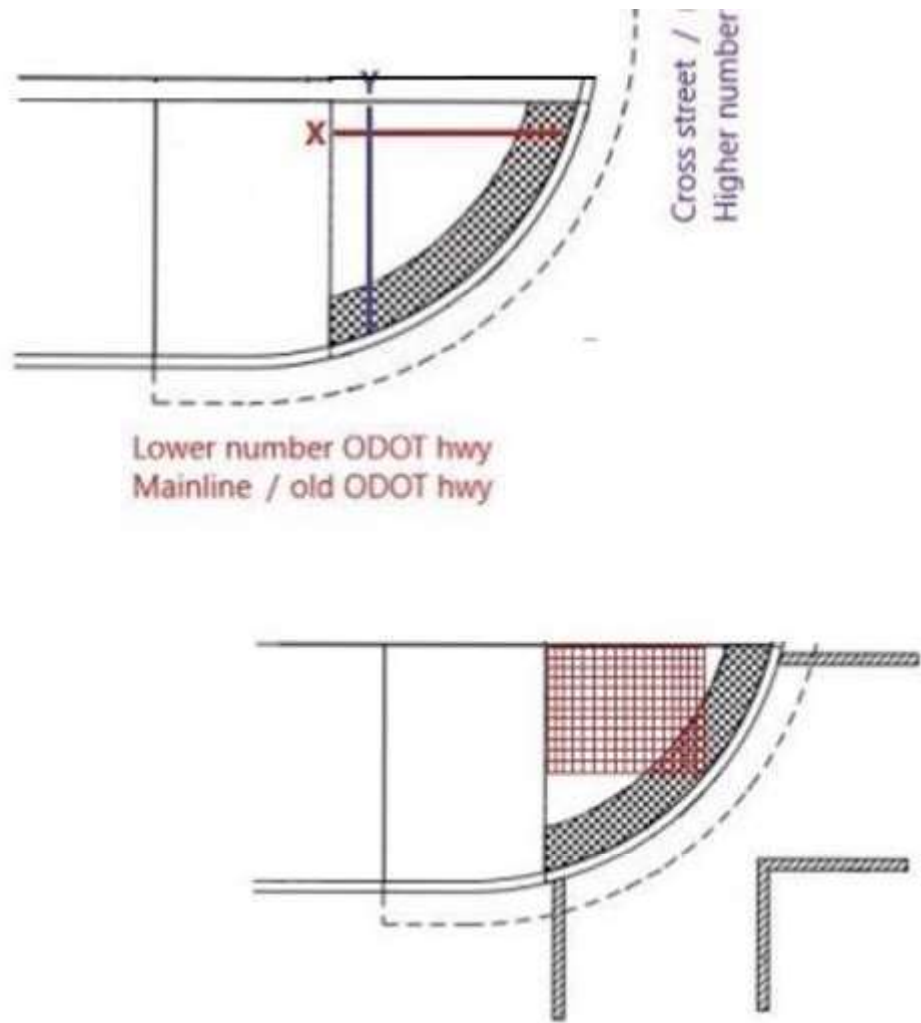

X and Y Orientation and Turning Space/Level Landing on a Depressed Corner, One Sided

Measuring Dimensions:

Measure the largest square that fits within the level wedge shaped Turn Space/Landing for the X and Y lengths. Remember though that the slopes in the entire Turn Space/Landing area need to be compliant.

Review the ODOT ADA Inspector Guide for Curb Ramps and Push Buttons for more information.



Review all figures and advance audio to the end before moving on.

Unit 7 Lesson 9: Determining Curb Ramp Style and Inspection Form Selection



You must click on all images before moving on to next Lesson.



05:21

Start Audio Narration

Do I use a Perpendicular, Parallel or Combination Curb Ramp Inspection Form?

It is not always apparent which style of curb ramp you are inspecting, and which form you should be using. The following is a recommended evaluation of curb ramps to help you determine which curb ramp styles you are looking at out in the field.

First, identify some of the components of the curb ramp system. Check if there are flares in the curb ramp system or a buffer zone with landscaping constructed in or adjacent to the curb ramp extents. If so, you probably have a perpendicular or combination style curb ramp.

Next, measure the running slopes on the surfaces adjacent to the turn space or level area and compare them to the slope of the road.



Combination or Perpendicular? Measure The Running Slope of the Panels Adjacent to Shared Turning Space

When at least one of the surfaces touching the turn space has a running slope exceeding 4.9% they are considered Ramp Runs 2 and 3 and the style is identified as a combination curb ramp. Use the Combination Curb Ramp Inspection Form.

If both surfaces touching the turn space have running slopes less than 5% and are the same grade of roadway the style is considered a perpendicular. Use the perpendicular curb ramp inspection form.



*Measure Adjacent Panels. Depending on Slopes for Each Ramp Run,
Determine if Perpendicular or Combination Style*

The perpendicular curb ramp form will generally only be used in flat terrains and when the walkway is the same running slope as the roadway grade.

When the turn space/landing area is depressed relative to the walkway, or tabled, it is a combination style construction.

When the curb ramp runs are curb tight, with no side treatments (flares, return curbs) on both sides it is probably a parallel curb ramp.



A Parallel Curb Ramp

When a curb ramp at a corner has only one ramp run touching the turn space/landing area, you must use the Unique Design Curb Ramp Form 734-5020G. The combination and parallel style curb ramp forms will not function unless they have both ramp run 2 and ramp run 3

measurements. Refer to the figures below as examples where a Unique Design Curb Ramp Form is required.



This looks like a parallel curb ramp with a ramp run missing. Use the Unique Curb Ramp Inspection form.

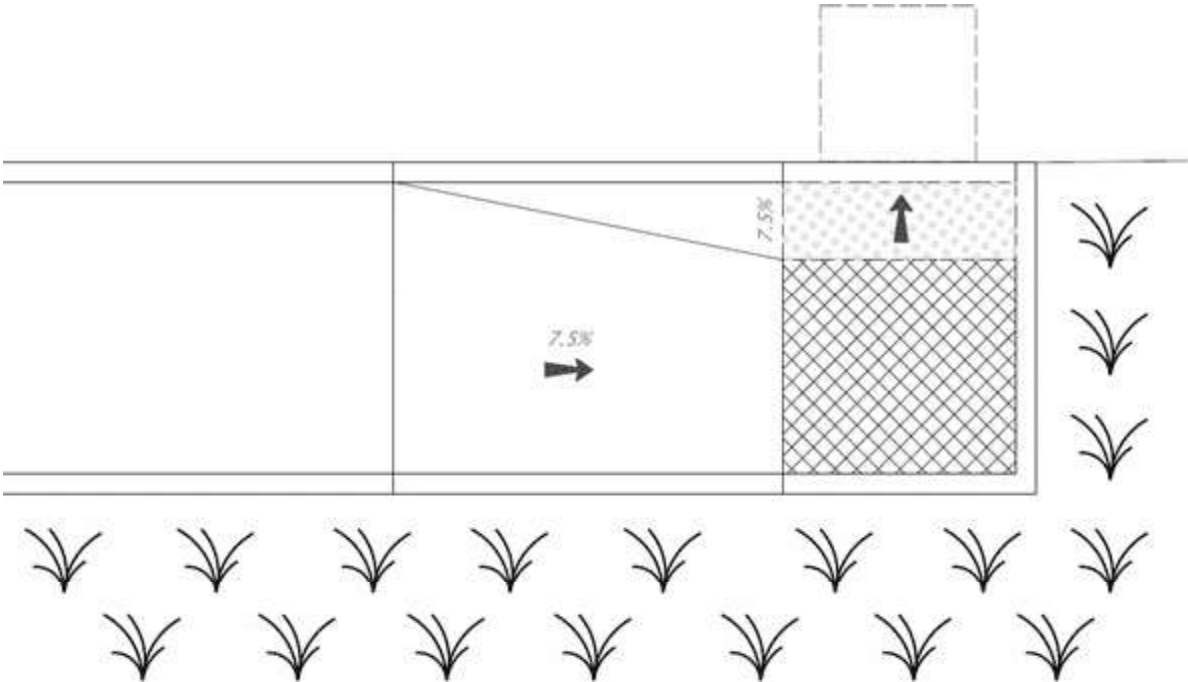

*This looks like a combination curb ramp with a ramp run missing.
Use the Unique Style Curb Ramp inspection form.*

Do I use a Unique Design or an End of Walk Curb Ramp Inspection Form?

Unique Design and End of Walk Curb Ramp Inspection Form selections often get confused. There are End of Walk curb ramp styles (RD950 and RD952) and a Unique Design curb ramp style (RD960). There are also End of Walk and Unique Design Curb Ramp Inspection forms.

End of Walk Locations

End of Walk Locations are defined by their physical location, not the style of curb ramp. They are generally located somewhere in between two intersections. They are not located at a street intersection.

When to use End of Walk Curb Ramp Inspection Form

Use an End of Sidewalk Curb Ramp Inspection Form when there is a curb ramp to transition pedestrians from a sidewalk to a shoulder and not at an intersection. It does not matter whether an End of Walk or Unique Design style curb ramp is designed. There should be no detectable warning surfaces on an end of sidewalk curb ramp because the purpose is to transition to the shoulder, not to cross the road.

Unique Curb Ramp Designs

This occurs when a Ramp Run 2 or Ramp Run 3 position is missing on a curb ramp system. Both ramp run positions could be missing as well, where the only portion for a pedestrian to use is a

level landing pad/turn space (a pedestrian pad). This might occur at a location with a pushbutton for a signal in a more rural environment.

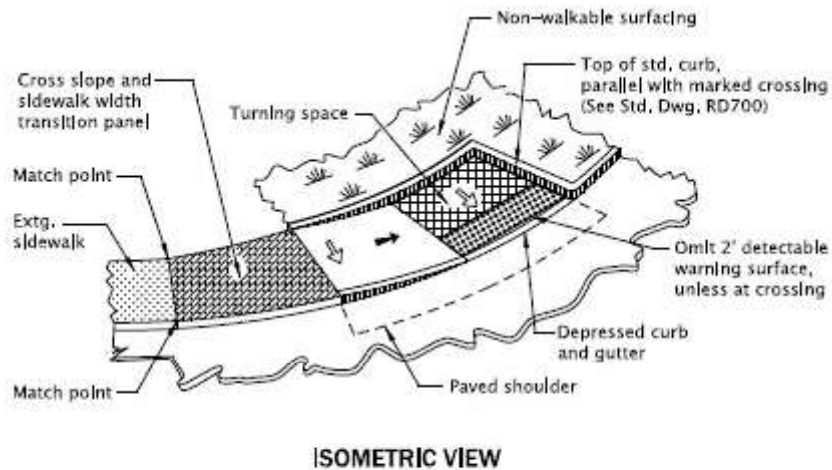

Unique Curb Ramp Design from Standard Drawing RD960

When to use Unique Design Curb Ramp Inspection Form

At an intersection serving a crosswalk, when a curb ramp design is either an End of Walk or Unique Design, inspect the curb ramp with the Unique Design Curb Ramp Inspection Form. The Unique Design Curb Ramp Inspection Form would also get used when there is a midblock crosswalk with a Unique or End of Walk Design.

When to use End of Walk Curb Ramp Inspection Form

Use an End of Sidewalk Curb Ramp Inspection Form when there is a curb ramp to transition pedestrians from a sidewalk to a shoulder not located at an intersection. It does not matter whether an End of Walk or Unique Design curb ramp style is constructed.



Use Unique Design Inspection Form	Use End of Walk Inspection Form
<p>At an intersection or a midblock pedestrian crosswalk when a Unique Design or End of Sidewalk design is used with Detectable Warning Surface.</p>	<ul style="list-style-type: none"> • Not at an intersection. • Midblock transition from sidewalk to roadway/shoulder with no street crossing. • There should not be Detectable Warning Surface.
<p>The curb ramp design could be a Unique Design (RD950) or an End of Walk Design (RD950 or RD952)</p>	<p>The curb ramp design could be a Unique Design (RD950) or an End of Walk Design (RD950 or RD952)</p>

 Review all figures and advance audio to the end before moving on. The quiz is on the next screen.

 After you have completed the quiz, close your window and the next Unit will become available in Workday Learning.