

## Unit 6: Introduction to Curb Ramp Attributes

---

### Course Navigation Tips:

- To complete each lesson, you must interact with the audio narration at the top of each section.
- You may drag the toggle on the playback bar to the last 5 seconds and let it play. This will allow the system to note it as complete.
- You are encouraged to complete the entire unit before closing in case your progress is not saved.

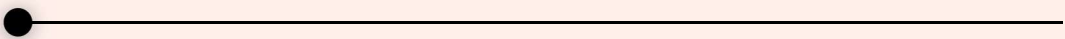

01:23

Start Audio Narration

---

In this Unit, expanded concepts on pedestrian accessible routes and pedestrian circulation areas will be covered. This includes transition segments to match back into old or existing infrastructure that is not being modified, surface requirements related to lips and gaps, side treatments adjacent to the curb ramp accessible route, and communication devices installed for pedestrians know as detectable warning surfaces.

Unit 5 described the essential components of curb ramps including ramp runs, turning spaces, curbing and gutter pans and how to measure them. This Unit will describe other curb ramp features that include essential elements and requirements of accessible curb ramps.

The following is a list of attributes and terms that you will learn in Unit 6.

- Traversable and Non-Traversable Surfaces
- Flared Side Treatments
- Detectable Warning Surfaces
- Transition Panels
- Clear Width
- Lips and Gaps

**CONTINUE**

# Unit 6 Lesson 1: Curb Ramp System Side Treatments

---



**You must click on all images before moving on to next Lesson.**



02:42

Start Audio Narration

---

Curb ramp system side treatments are types of surface treatments in a curb ramp system that are used outside of the pedestrian access route (PAR).

Some side treatments are hard surfaces that are walkable but may not be accessible. These surfaces are called traversable and would be within the pedestrian circulation Area. Refer to Unit 5 lesson 1 for discussion on pedestrian circulation area.

Some side treatments are not meant to be walked on and sometimes are provided to deter pedestrian use, such as landscaping, loose or rough surfaces. These surfaces are referred to as non-traversable. Non-Traversable surfaces are outside of both the pedestrian access route and the pedestrian circulation area.

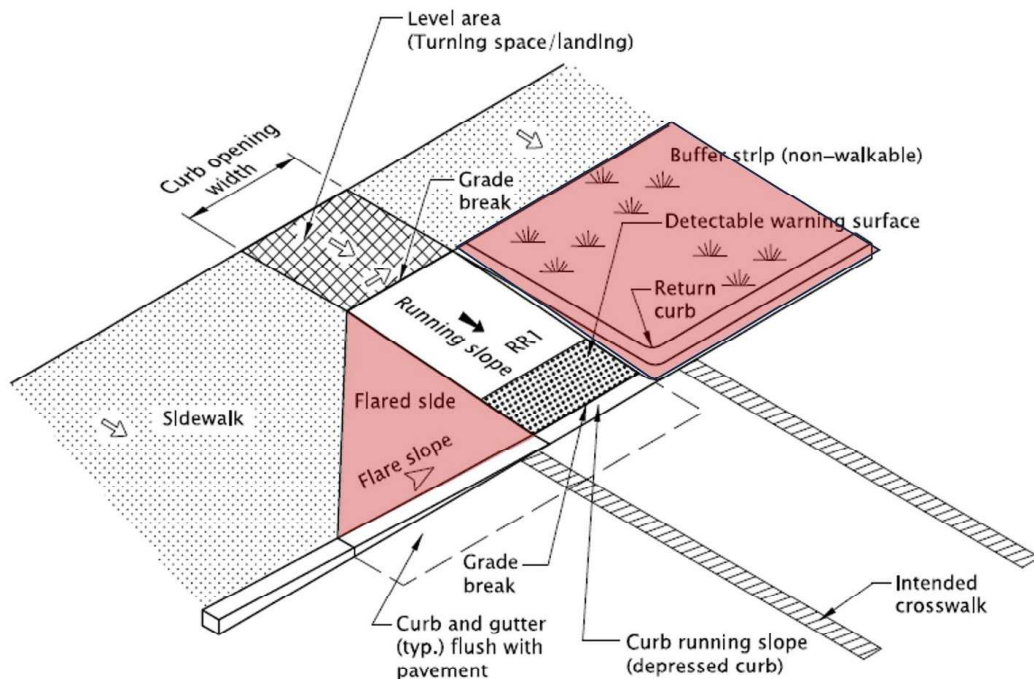

*Side Treatments*

## Traversable and Non-Traversable Surfaces

Traversable surfaces are hard surfaces that a pedestrian can walk on. Traversable surfaces may or may not be accessible. For example, the surface may be a concrete surface that could be walked on but it may not meet the requirements for accessible slopes or clear widths.

A common traversable side treatment is a concrete flare with contiguous concrete surfacing on all sides (no adjacent landscaping). Traversable surfaces include concrete, asphalt and brick pavers. A well compacted and graded angular gravel that can be walked on and remain stable when used by a wheelchair may be considered traversable.

Non-traversable surfaces are not suitable for pedestrian travel and are not accessible. You may hear the terms hardscaping and soft scaping to describe a non-traversable surface next to a curb ramp or flare in the curb ramp system. It is commonly referred to as a landscape buffer.



Non-traversable surface types include loose round durable rock, grouted durable rock, grass, planted areas, or bark dust.

Flared slope side treatments are sometimes constructed between a curb ramp run and a non-traversable surface. Compared to a raised return curb, flared side treatments provide a less abrupt transition between the curb ramp and the non-traversable surface. The flare can also increase the pedestrian circulation area for individuals to stand on when waiting to cross the street. When a flare is used as a side treatment between the curb ramp and a non-traversable surface, it is considered non-traversable on the Curb Ramp Inspection Form.

Scroll through the examples of traversable and non-traversable surfaces.



**Traversable**

---



## Non-Traversable

---



**Traversable on the Left and Non-Traversable on the Right**

---



**Non-Traversable on the Left and Traversable on the Right**

# Right

---

## Activity: Traversable and Non-traversable Surfaces.

Drag the surface type into the correct box, either traversable or non-traversable surface.

Traversable Surfaces

PCC concrete

Unit pavers or bricks

Asphalt

Colored concrete

---

---

**Graded and compacted  
angular gravel**

**Patterned or scored concrete**

**Non-traversable Surfaces**

**Bark dust or wood chips**

**Loose cobbles**

**Grass**

**Durable grouted rock**

**Sand**



03:34

Continue Audio Narration

---

## Flared Side Treatments

A flared sloped surface is a component constructed as a side treatment to the entering ramp run from the roadway of a curb ramp system. The flare transitions the vertical edge created by a curb to a flush curb ramp opening.

Important terms for inspection of flared slope surfaces are traversable and non-traversable.

Objects such as signs, poles, utility valves and fire hydrants may be installed on a flare. These types of objects are permitted to reside on a flared side. Since these objects do not prohibit a pedestrian from walking across the flared side treatment it does not make the flare side treatment with vertical objects non-traversable. It is only when a non-traversable surface is adjacent to the flare is the side treatment considered non-traversable.



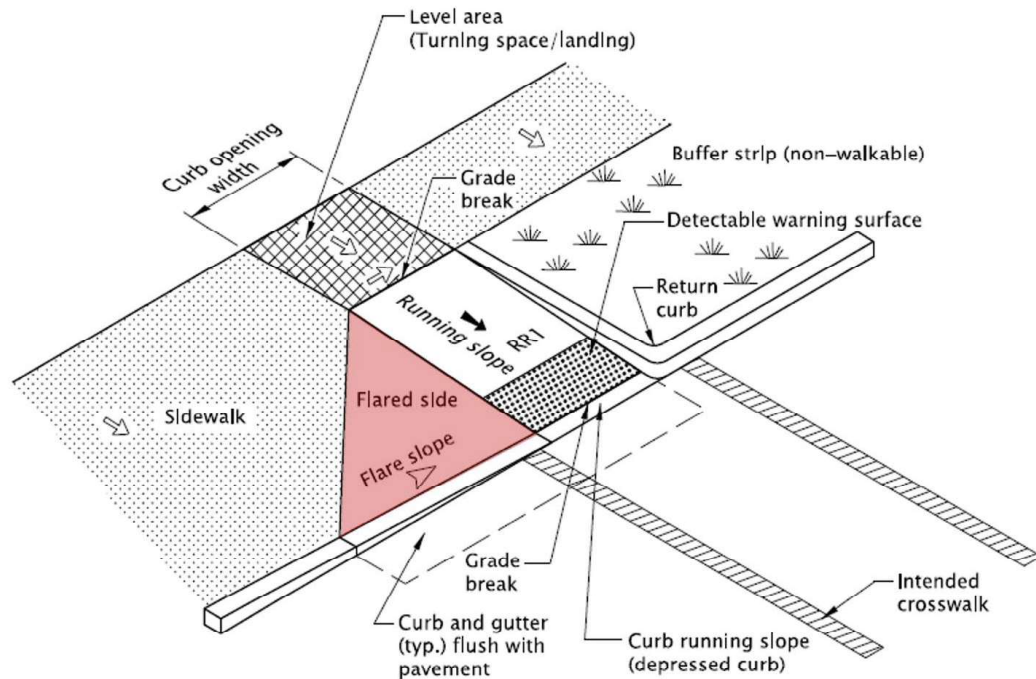

*Flared Side Treatment*

## Flared Side Treatment Measurements

All flared slope side treatments (both traversable and non-traversable) are measured and cannot exceed 10.0% grade. Measure the flare slope with the smart level on top of the curb and along the first foot parallel to the curb.

Look for lips or vertical discontinuities where the top surface of the curb and flare panel meet. ODOT construction practices do not typically call out monolithic construction of curb ramp systems, so top of curbs and flare panels are inspected because they are typically two separate concrete pours. They should be flush at finish construction.

Objects such as signs, poles, utility valves and fire hydrants may be installed on a traversable flared slope side treatment. Objects in the curb ramp system proximity are recorded and noted in the comments section of the inspection form and is discussed later in the training.

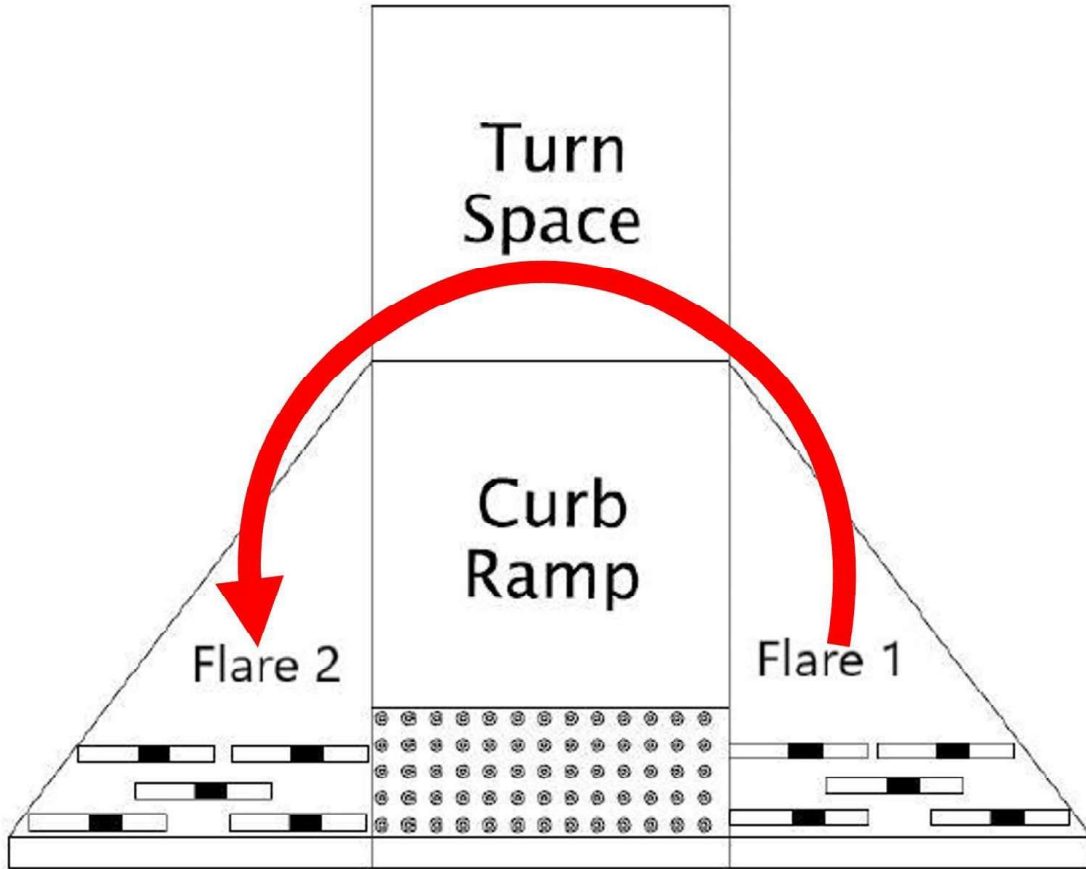

*Flare Numbering Scheme and Smart Level Placement for Flare Slope Measurements.*

Flared slope numbering follows the counterclockwise numbering convention. The right flared side treatment as you enter the curb ramp system from the roadway is Flare 1 and the left flare is Flare 2.

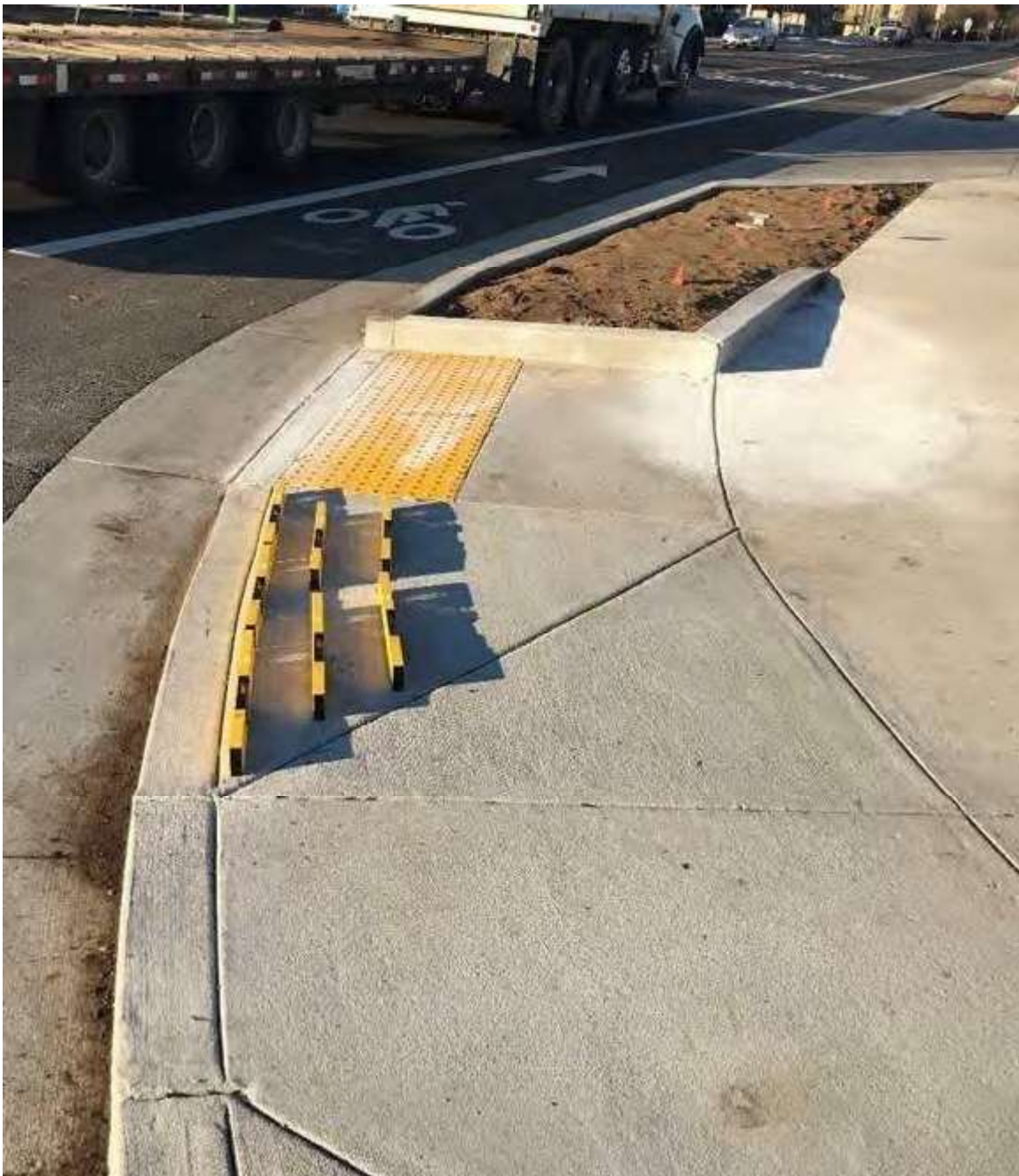

*How to Place Smart Levels on a Flare*

---

**Flared Side Measurements with Directional Curbs**



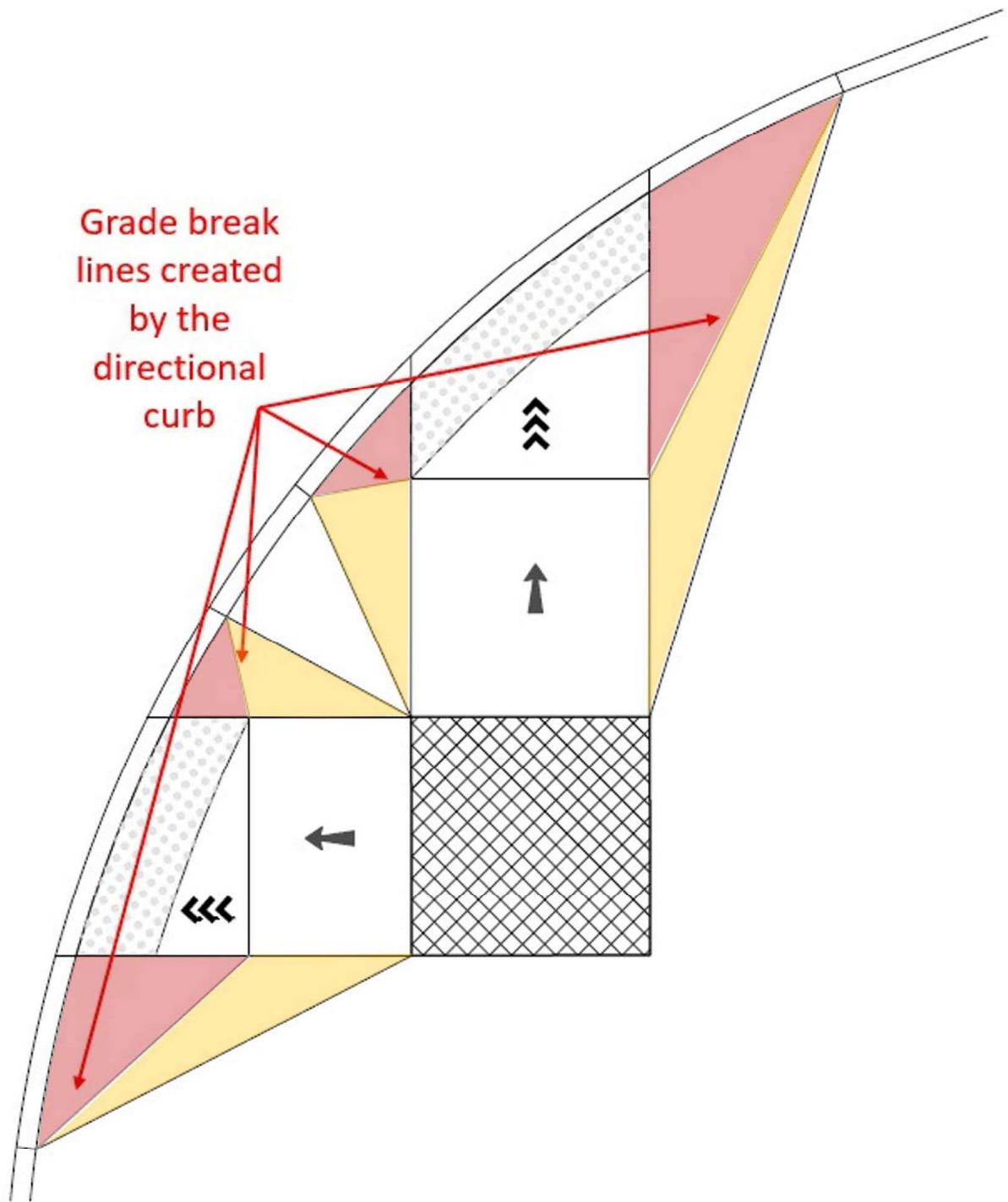

Flares on a Directional Curb System

Directional curbs connect the end of ramp run to the edge of the crosswalk. Directional curbs do not match the running slope of the ramp run . There is a perpendicular grade break at the top of the directional curb and bottom of the ramp run. Where directional curbs are constructed an additional grade break is often created in the surrounding concrete adjacent to the ramp run

surface. The flared measurement is still at the back of curb parallel; it is not on the surface plane of either polygon created by the grade break or tooled dummy joint.

## Snow Curb Return

Snow curb returns are a modified return curb with a tapered surface at the corner. These are most often provided in locations where snow plowing equipment is used. If a snowplow contacts a snow curb taper at the corner it is less likely to damage the surrounding curbing. These are not the same as a curb ramp system flared slope side treatment and are not to be measured as flares. **Snow Curb Returns should be regarded as return curb element and is not measured or recorded on the inspection form.** This treatment is a newer treatment developed for ODOT highways for curb ramps.

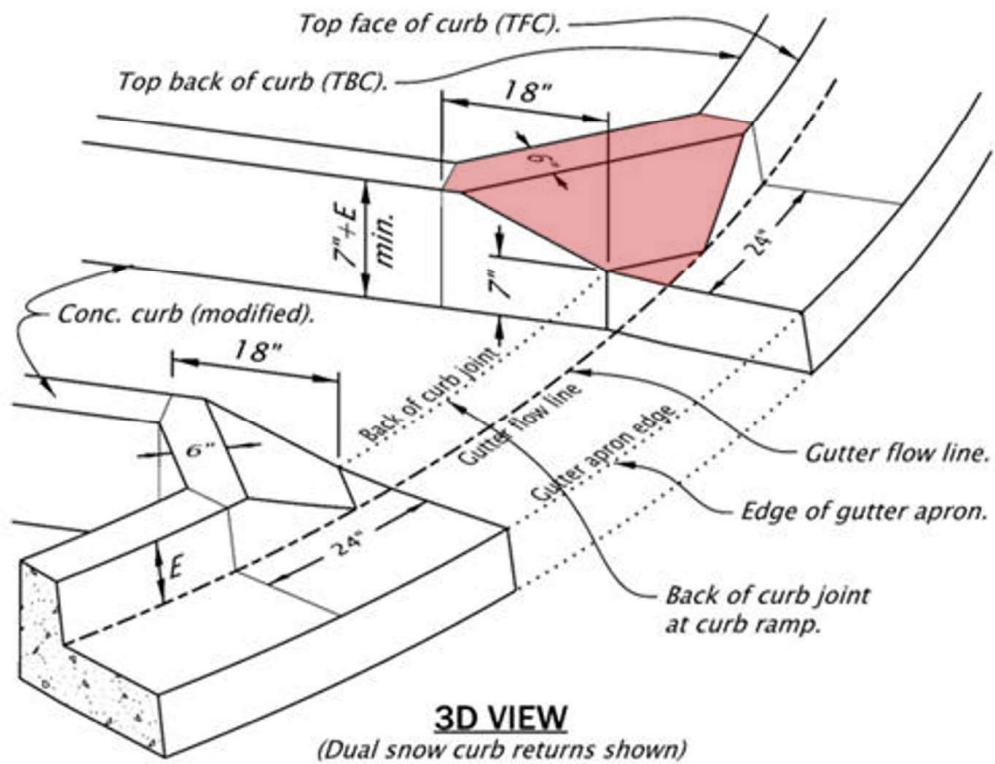

**SNOW CURB RETURN NOTES:**

1. Details show potential orientations of curb/gutter & curb ramps. See curb ramp detail sheets for specifics.
2. Between adjacent snow curb returns, allow 12" min. of curb length with E=6" nom. (E=3" min.) unless otherwise shown.
3. For curb details not shown, see dwg. no. RD700 and plans.

**SNOW CURB RETURN**

(As directed by Engineer.)

Illustration of Snow Curb Return

**Flare Slope Activity**

In the activity below, drag and drop the Flare Slope 1 or 2 text box over the appropriate flare. If it is dropped correctly, it will turn green. If it is dropped incorrectly, it will turn red. Continue until both Flare Slope text boxes are green.

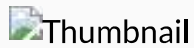

02:00

---

Continue Audio Narration

---

## **Non-Traversable Grouted Durable Rock (GDR) or Stamped Concrete Rock Design Exception.**

A grouted durable rock treatment consists of placing durable round rock into concrete/grout such that there is some exposure to make this undesirable, detectable and discernable to pedestrians that the area is not intended for pedestrian to walk on. This is a non-traversable hardscape treatment at sidewalks and curb ramps systems. The intent is to provide an area that is discernable as a non-walkable surface to all people and prevents cross travel across the curb return and unexpected mis-steps (drops).

General Roadway Design Exceptions for the installation of grouted durable rock are required before installation and the control number is recorded on the inspection form. Review the project special provisions for installation requirements. Photos shown are examples of some grouted durable rock installations used at curb ramps and islands. These are newer treatments designed for use at curb ramps on ODOT curb ramps systems and are considered experimental.





## Flare FAQ's

**i** Q: Which flare is Flare 1 and Flare 2?

A: Facing the ramp from the street Flare 1 is to the right and Flare 2 is to the left, following the same convention as other assets, which is counterclockwise.

**i** Q: ODOT Standard Drawing RD910 references a buffer strip (see Note 8). Note 8 references return curbs may be provided in lieu of flared slope only if protected from traverse travel by landscaping. Can the area be concrete or stamped concrete?

A: No. It needs to be non-traversable material that cannot be mistaken as a useable walking surface which include landscaping materials described as soft scaping (for example, bark mulch or plantings) or an approved alternative treatment such as grouted durable rock with a design exception.



Review all figures, complete activities and advance audio to the end before moving on.

## Unit 6 Lesson 2: Detectable Warning Surfaces

---

 You must click on all images before moving on to next Lesson.

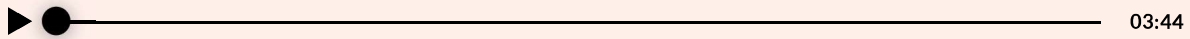

Start Audio Narration

---

### Detectable Warning: Truncated Domes in Safety Yellow

A detectable warning surface is a standardized feature built in or applied to walking surfaces or other elements to alert pedestrians they are entering or exiting an area of vehicular travel. Detectable warning surfaces are generally placed where pedestrians transition from a pedestrian only walking surface to a roadway surface including at the bottom of curb ramp runs, on shared-use (multi-use) paths, and at island crossings. Detectable warnings are omitted in some circumstances, such as end of walk style curb ramp systems when they do not provide access to a street crossing. Detectable warning surfaces are installed at transit loading areas and at railroad crossings to alert pedestrians of a hazard.

ODOT standard color for truncated domes is safety yellow. Alternative colors must be approved with a General Design Exception (DE) that is signed by the State Traffic Roadway Engineer when installed on or along the State highway.



Perpendicular Style Ramp with Safety Yellow Truncated Dome Installation

---

## RD 900 Series Standard Drawings

STANDARD DRAWINGS

### Evaluating Detectable Warning Surfaces

Correct installation occurs when the detectable warning surface has been installed for the full width of the ramp opening. Correct installation maintains the proper dome spacing and is at least two feet deep in the direction of pedestrian travel. When there is no curb installation, the detectable warning surface is placed at the edge of the roadway.

Placement should be consistent with the standard drawings. Note that the gap on the edges cannot exceed two inches and this is reflected in the standard drawings.



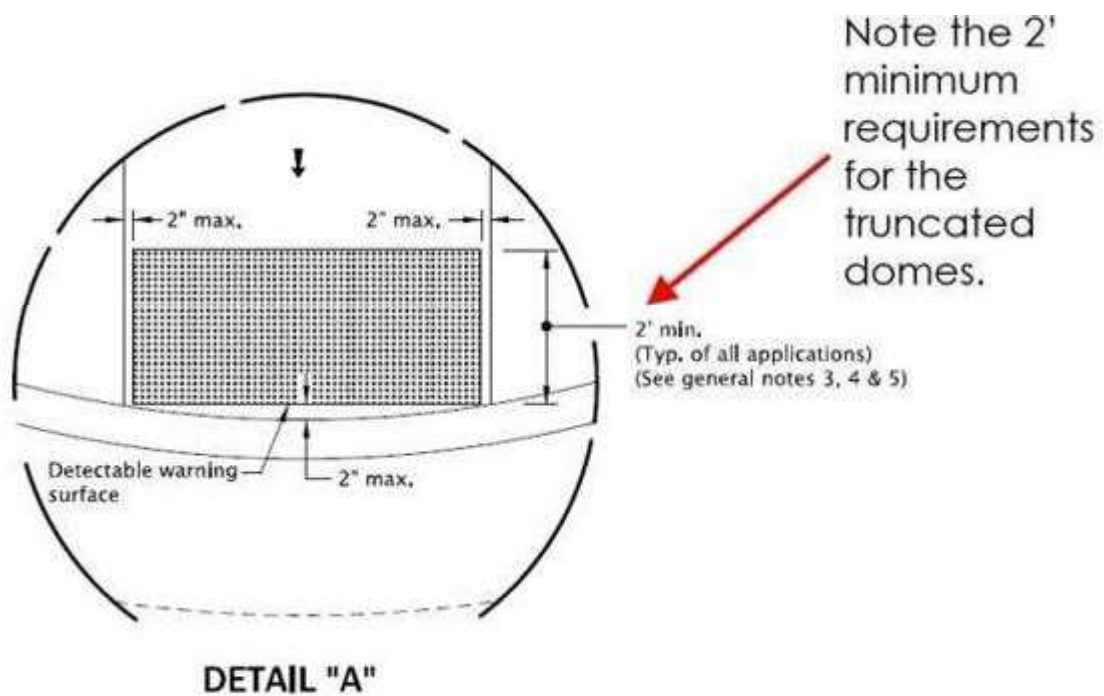

RD902 Detail of Detectable Warning Surface (Truncated Domes)  
Placement

---

## FAQ's

**Q:** How do I meet the minimum 2-inch requirement shown on Oregon Standard Drawing RD902, detail "A", for truncated domes when the ramp is on the radius?

**A:** ODOT has various manufactured products on the Qualified Products List. Some supply radial dome sections and the detectable warning surface can be ordered with radius pieces that are customized for the site condition. Some products will need to be cut and modified for installation to meet the requirements of detail "A". The 2-inch gap will be verified during inspections.

**i** Q: Figure below shows the detectable warning surface cut to fit the curve of the curb, is this an acceptable practice?

A: No. A continuous section of detectable warning surface that is 2 feet deep in the direction of the pedestrian travel for the entire curb ramp width is required. The placement location of the detectable warning surface is dependent on the curb ramp style and/or on the distance between the grade break to the back of curb (see applicable Oregon Standard Drawings).



Improper Detectable Warning Surface Cut To fit The Curve of The Curb

---

**i** Q: Can detectable warning surfaces be placed along a radius in such a way that creates gaps along the curb but the panels are touching at the back corners?

A: Oregon Standard Drawing notes indicate “Detectable warning surface shall be placed at the back of curb for a minimum depth of 2 feet.” The two feet must be completely filled with the detectable warning surface and maintain the required dome spacing dimensions per the Oregon Standard Drawings. Gaps in between panels will not likely maintain the required dome spacing requirements with the gaps shown below, and the detectable warning installation is not full width.

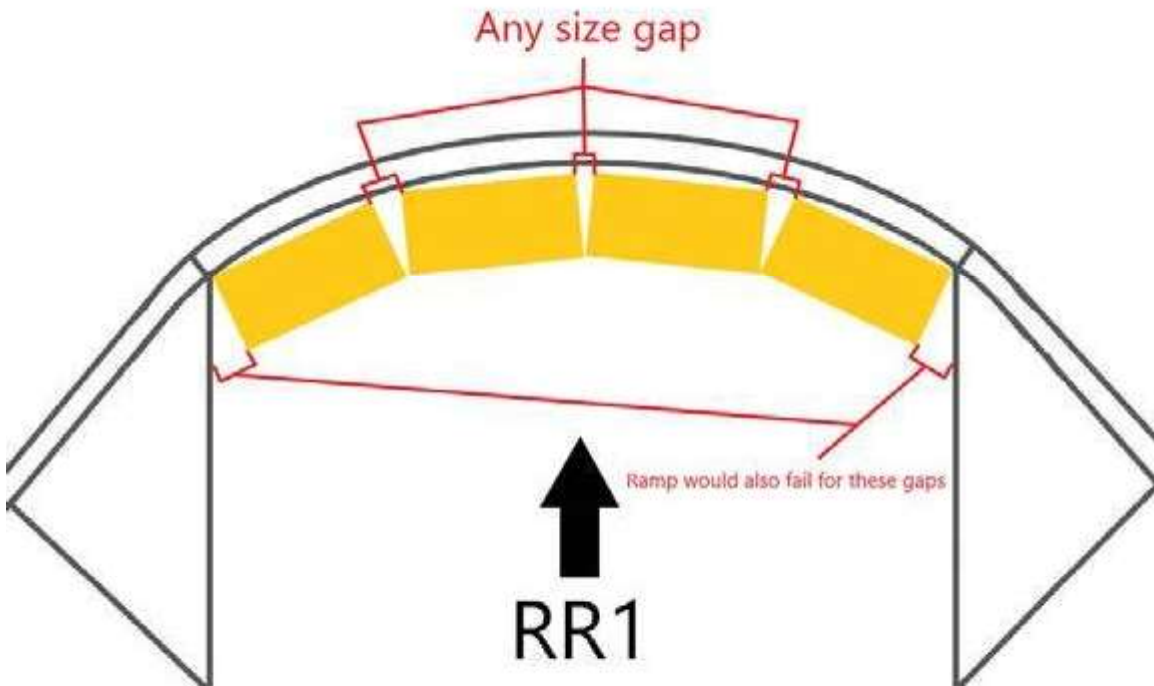

Improper Detectable Warning Placement Example

---



## Correct Installation of Adjacent Panels

---

### **Adjacent Detectable Warning Surface (DWS) Panels**

Figure shows the correctly installed detectable warning surfaces with an adjacent panel, maintaining the truncated dome spacing per RD902.

Scroll through the illustrations below of Detectable Warning Surface details from Oregon Standard Drawing RD900 Series.

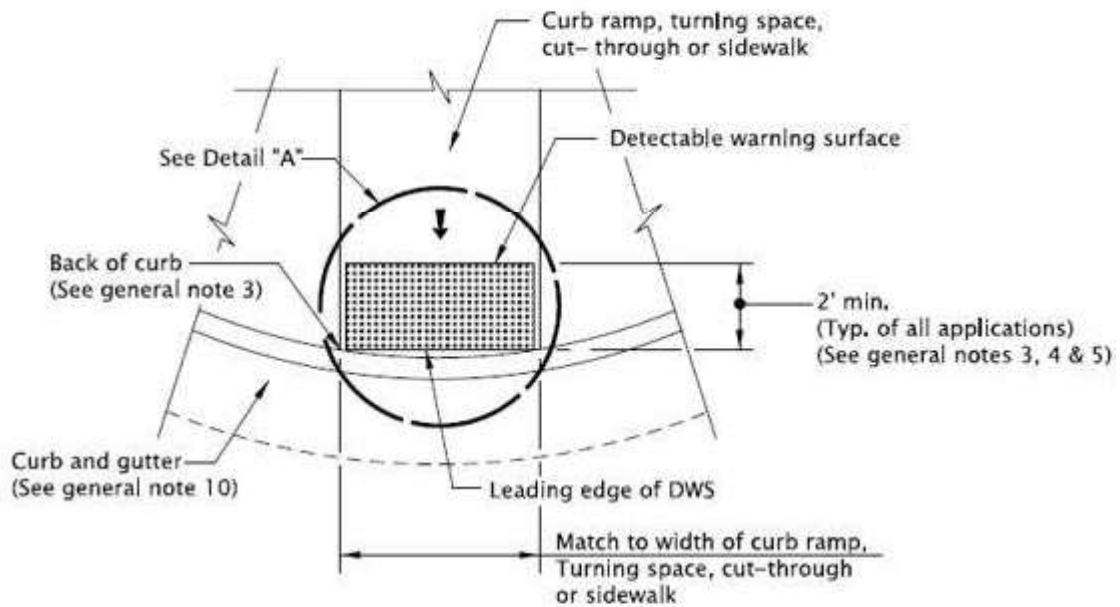

**DETECTABLE WARNING SURFACE DETAIL**

***Source: Standard Drawing RD902***

Standard Drawing RD902

---



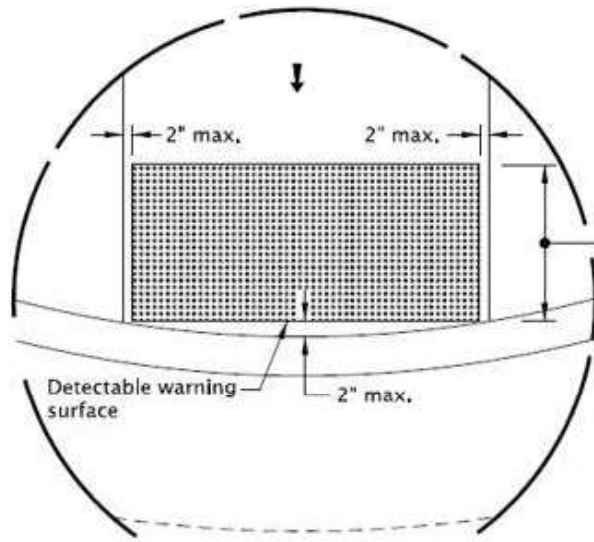

2' min.  
(Typ. of all applications)  
(See general notes 3, 4 & 5)

Note the 2'  
minimum  
requirements  
for the  
truncated  
domes.

DETAIL "A"

***Source: Standard Drawing RD902***

Standard Drawing RD902

---

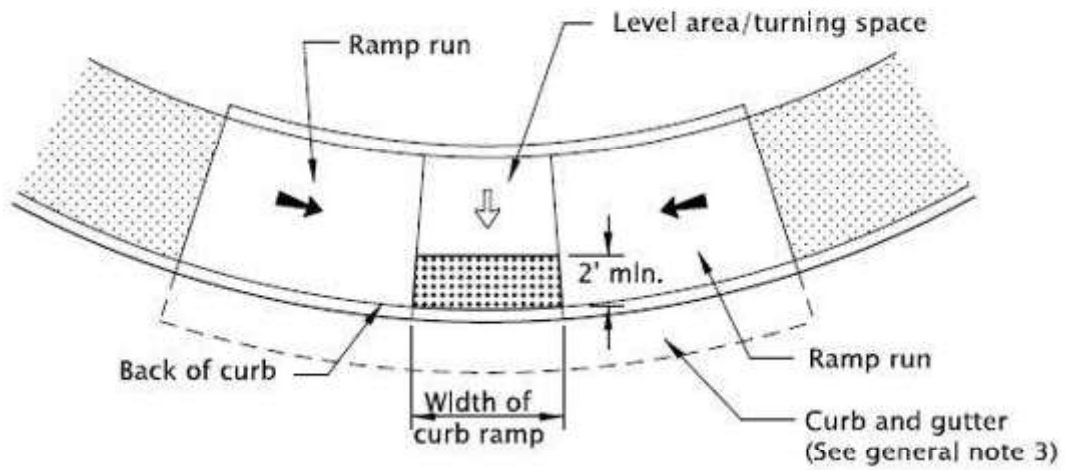

## PARALLEL CURB RAMP

***Source: Standard Drawing RD904***

Standard Drawing RD904

---

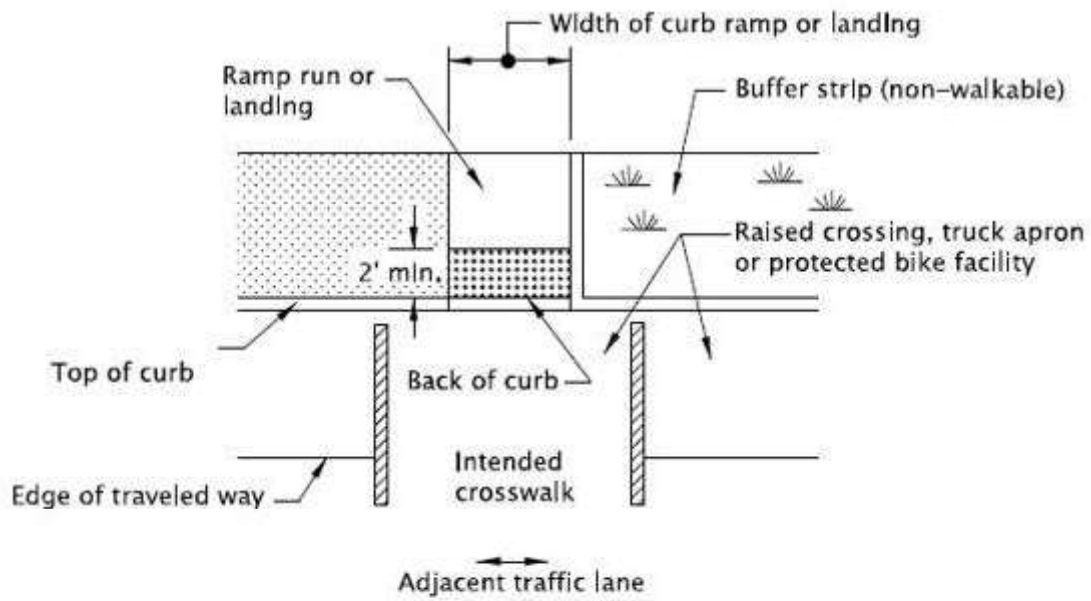

**RAISED CROSSING, TRUCK APRON  
OR PROTECTED BIKE FACILITY**

***Source: Standard Drawing RD904***

Standard Drawing RD904

---



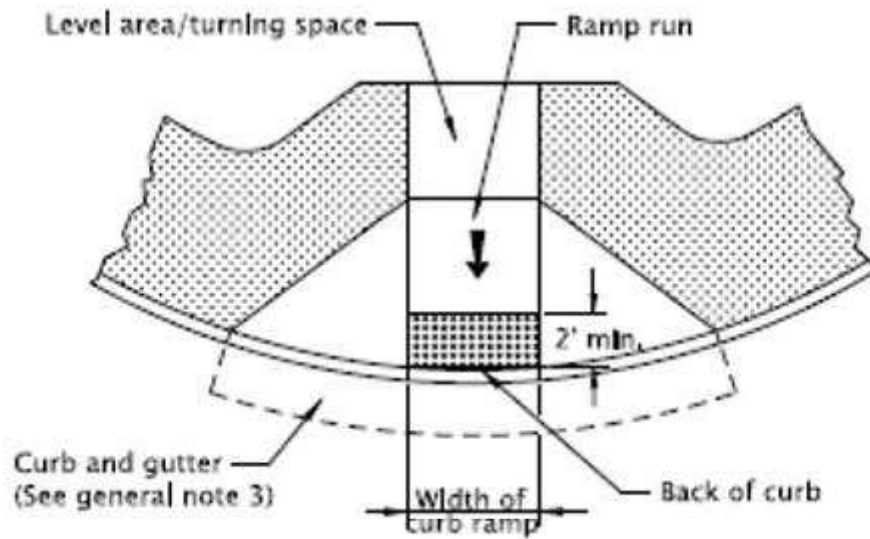

**PERPENDICULAR CURB RAMP  
GRADE BREAK IN FRONT OF CURB**

***Source: Standard Drawing RD904***

Standard Drawing RD904

---

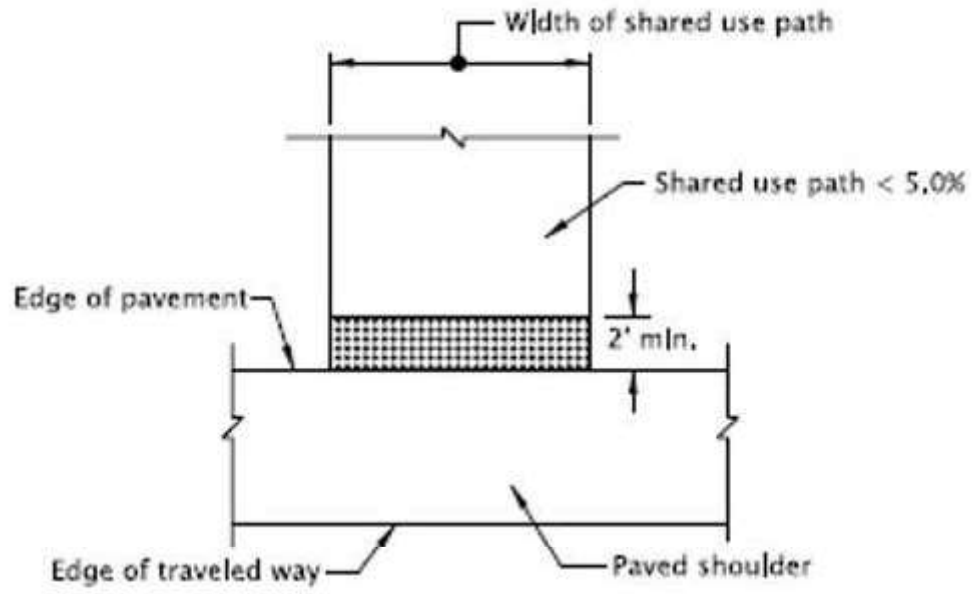

## SHARED-USE PATH CONNECTION

***Source: Standard Drawing RD904***

Standard Drawing RD904

---

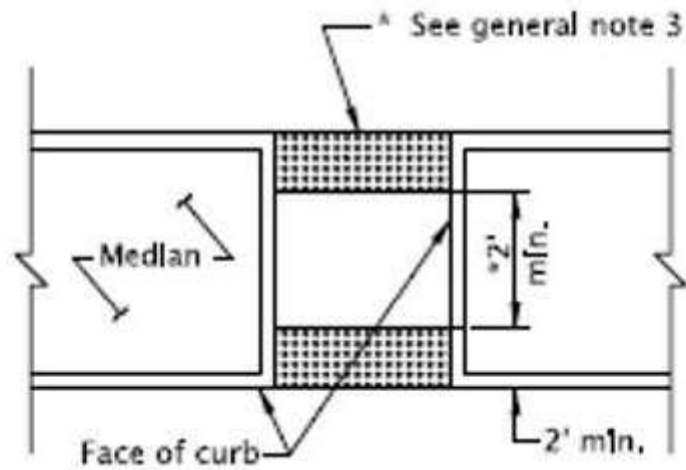

\* Omit detectable warning surfaces if less than 2'

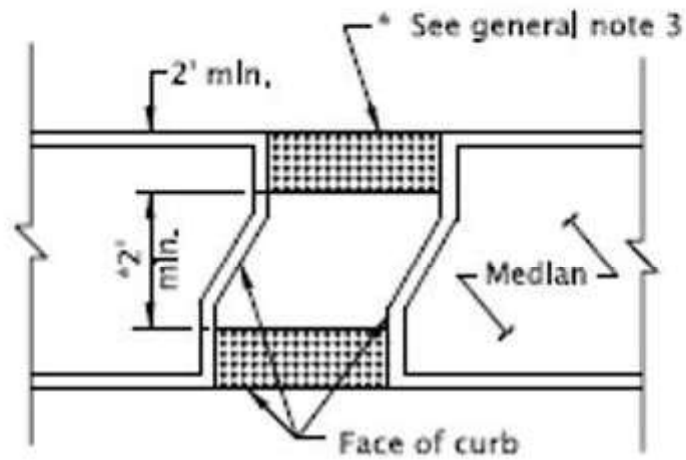

**CUT-THROUGH**  
(Asph. conc. surface shown)

## MEDIAN CROSSING

***Source: Standard Drawing RD906***

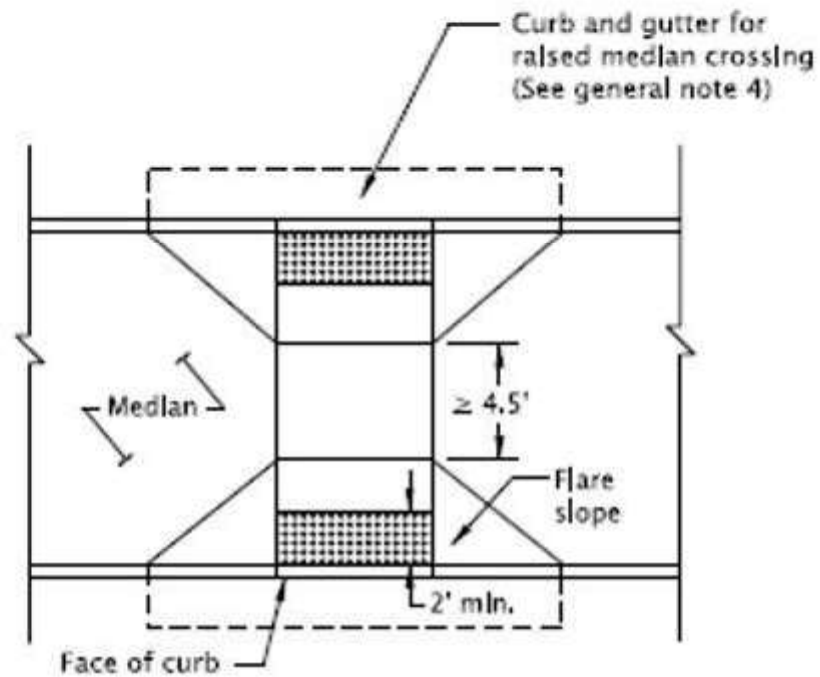

**RAISED MEDIAN**  
(P.C. conc. surface shown)

## MEDIAN CROSSING

***Source: Standard Drawing RD906***

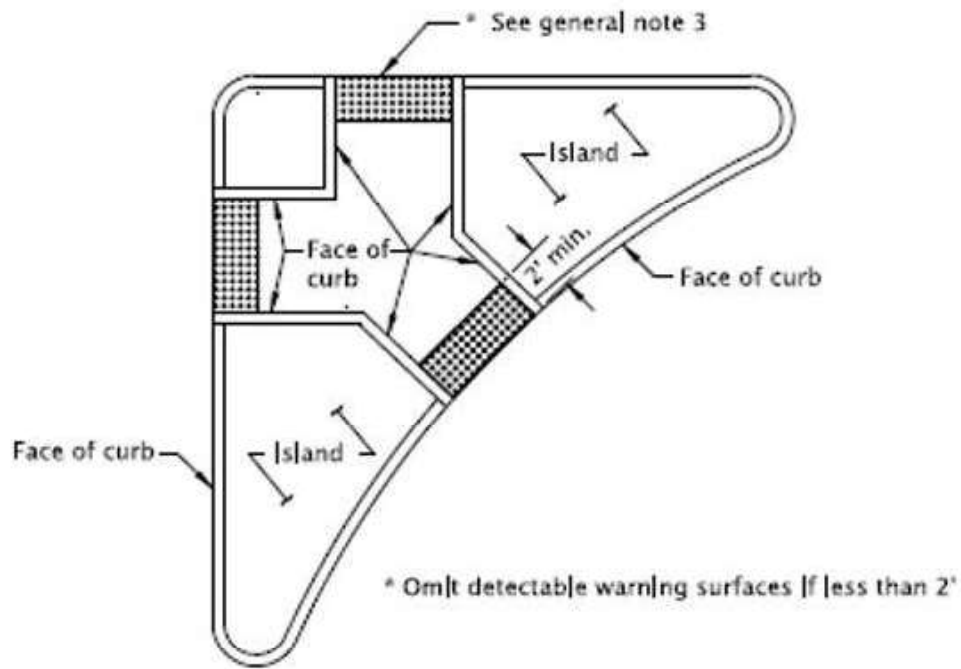

**CUT-THROUGH ISLAND**  
 (Asph. conc. surface shown)

## **RIGHT TURN CHANNELIZATION ISLAND**

***Source: Standard Drawing RD906***

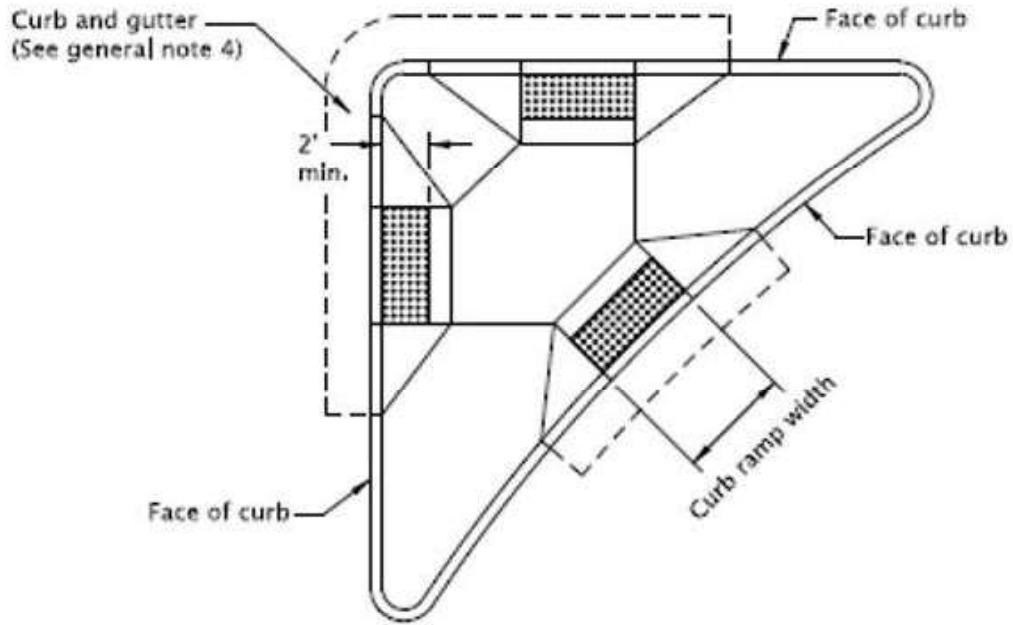

**RAISED ISLAND**  
(P.C. conc. surface shown)

## **RIGHT TURN CHANNELIZATION ISLAND**

***Source: Standard Drawing RD906***

Standard Drawing RD904

---

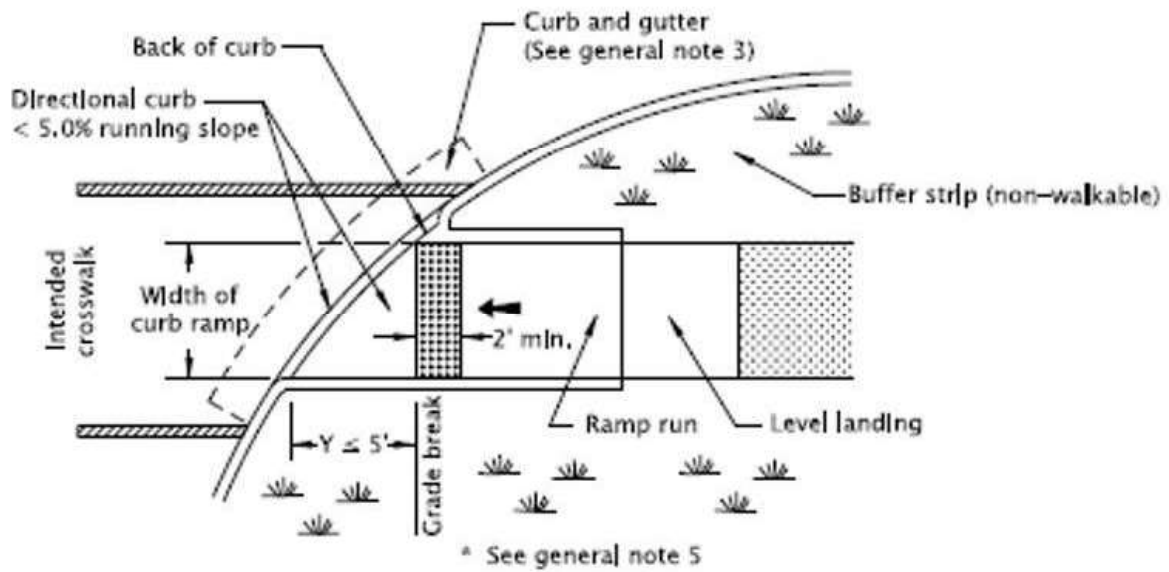

**CURB RAMP CROSSING**  
**GRADE BREAK  $\leq$  5 FT. FROM BACK OF CURB**

***Source: Standard Drawing RD905***

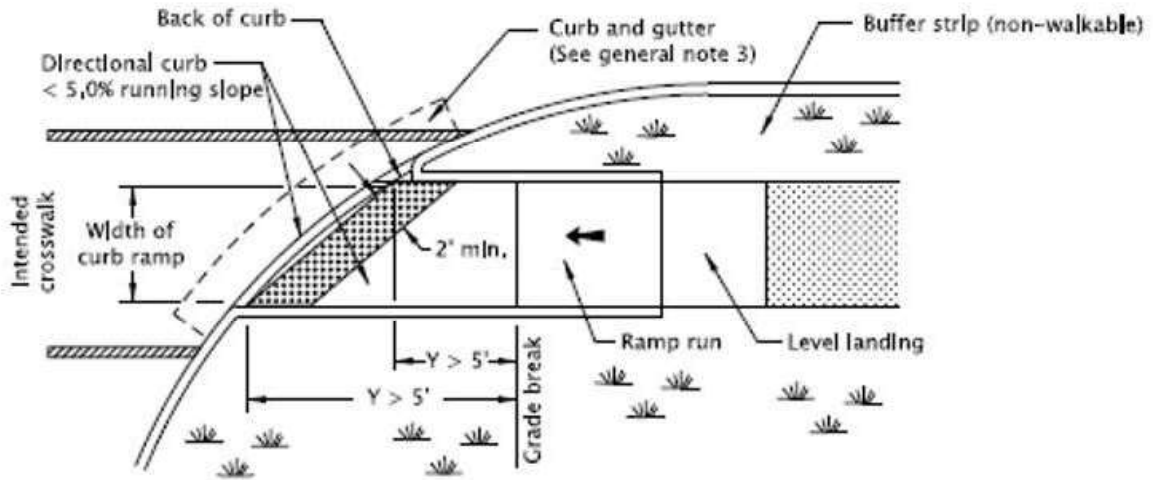

**CURB RAMP CROSSING**  
**GRADE BREAK > 5 FT. FROM BACK OF CURB**

***Source: Standard Drawing RD905***

Standard Drawing RD905

---



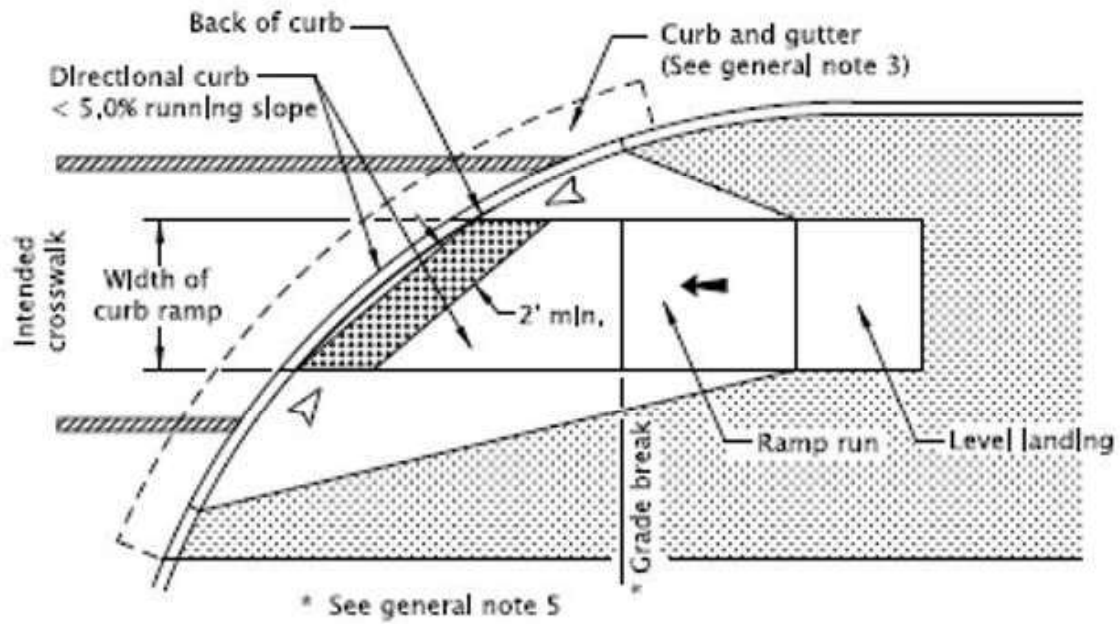

**CURB RAMP CROSSING**  
**DIRECTIONAL CURB WITH FLARED CONSTRUCTION**

***Source: Standard Drawing RD905***

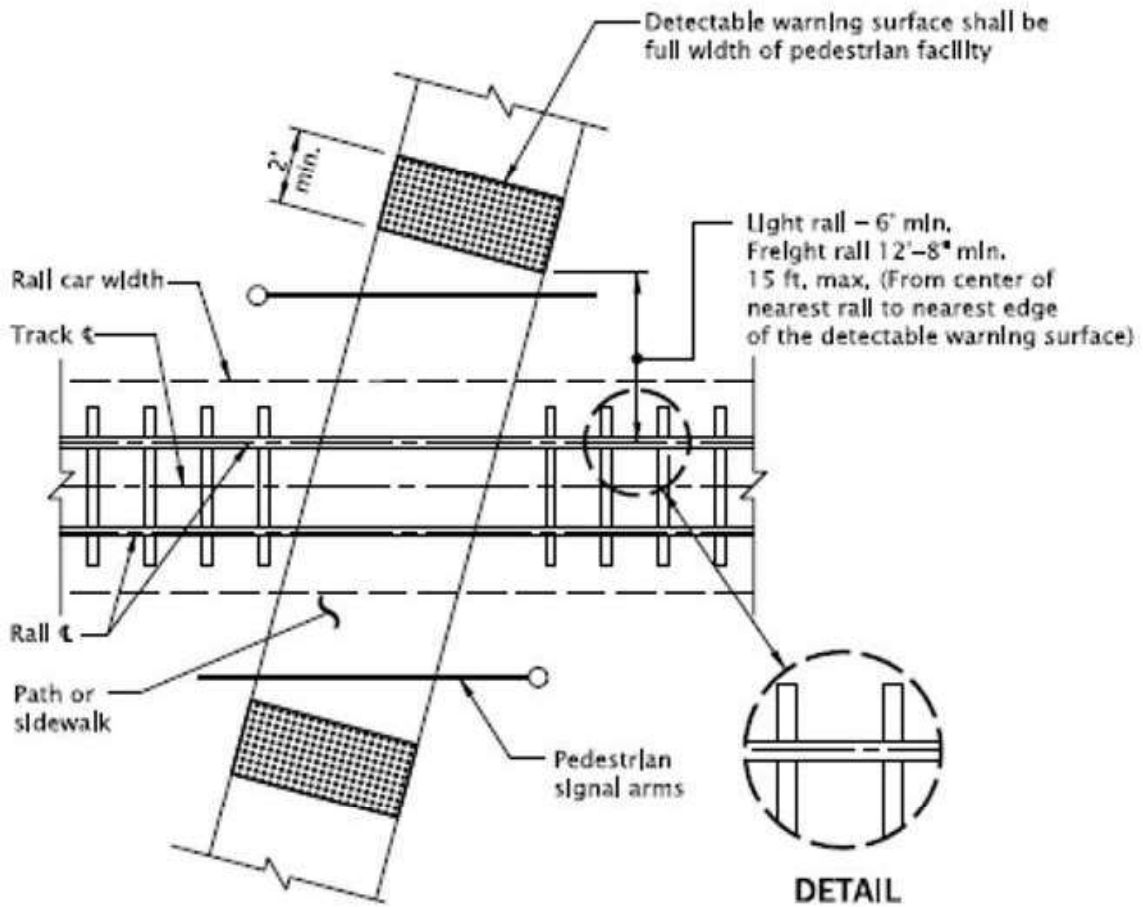

## AT-GRADE RAIL CROSSING

***Source: Standard Drawing RD908***

Standard Drawing RD908



## Detectable Warnings on Directional Curbs

The placement of detectable warning surface (DWS) is determined by the length of the directional curb. Determine the longest length of the directional curb parallel to the running slope and if the side treatments are traversable to pedestrians.

When the longest length is less than or equal to 5.0 feet and each side is abutting a curb return with no traversable material, the DWS are installed above the grade break on the Ramp Run. Pedestrians in this circumstance should not be crossing the non-traversable material and are unlikely to miss the detectable warning surface when approaching the crosswalk.

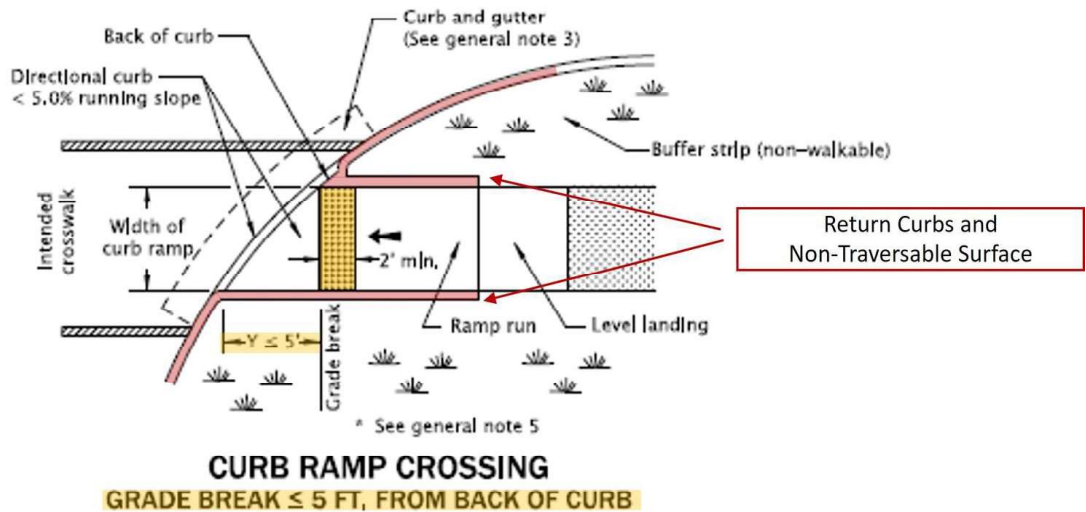

RD905 Detectable Warnings are Applied on Ramp Run when Directional Curb is Less Than or Equal to 5 feet AND the Curb Ramp System Has Return Curbs

When the longest length is less than or equal to 5.0 feet and each side is abutting a curb return with non-traversable material, the DWS are installed above the grade break on the Ramp Run.

When a flare is present or the longest length is larger than 5.0 feet, the DWS is installed at the back of the curb.

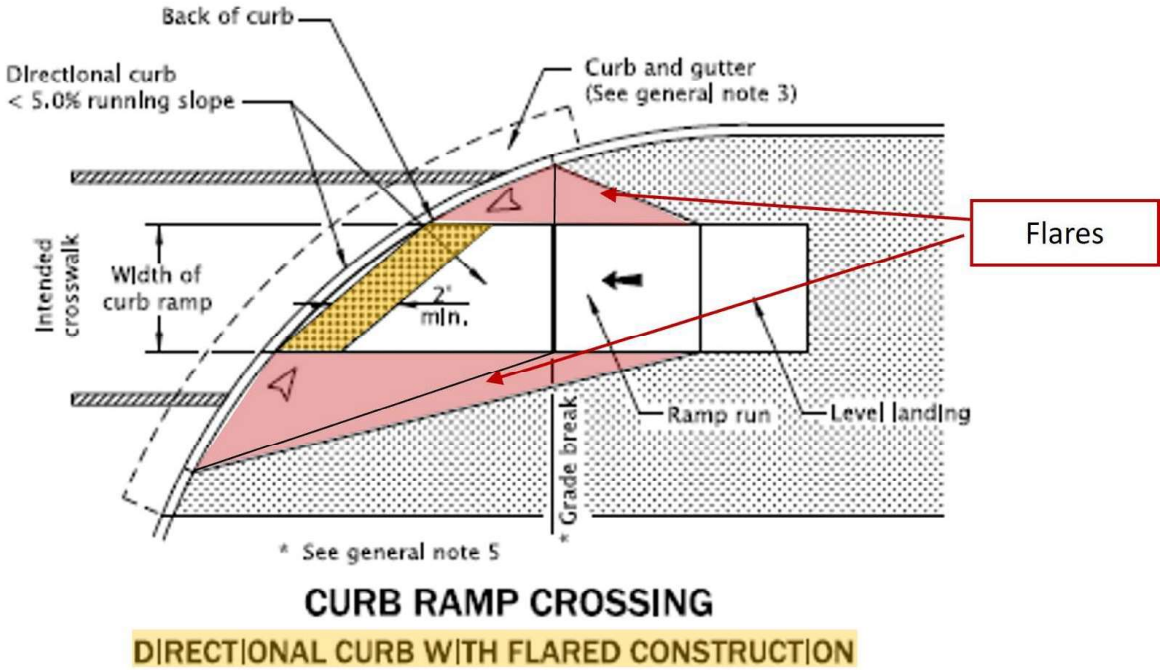

RD 905 Detectable Warnings are Applied at Back of Curb when  
Directional Curb has Flares

---

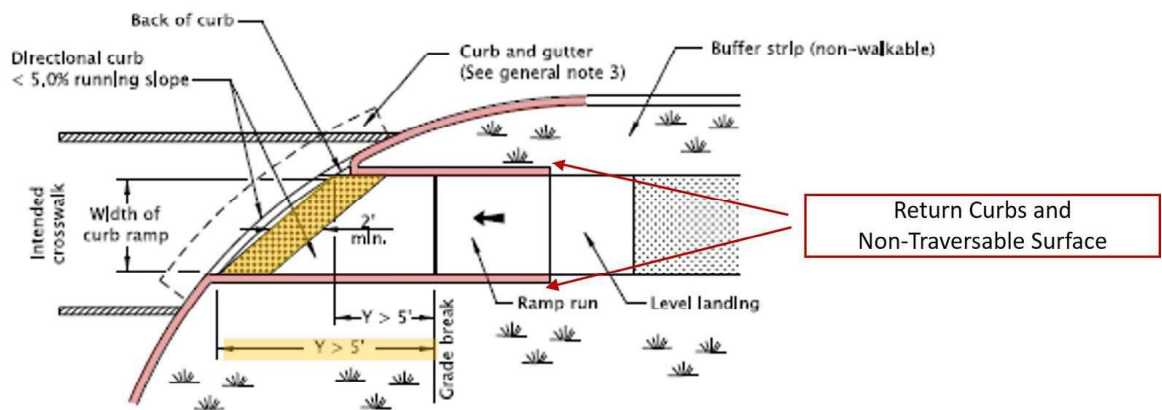

**CURB RAMP CROSSING**  
**GRADE BREAK > 5 FT. FROM BACK OF CURB**

RD905 Detectable Warnings are Applied at Back of Curb when Directional Curb is Greater Than 5 feet AND the Curb Ramp System Has Return Curbs.

Detectable Warnings are Applied at Back of Curb when the Directional Curb is Greater Than 5 feet AND the Curb Ramp System has Return Curbs.

Pedestrians generally stop and signal intent to cross near the curb of the crosswalk, so when the distance of the grade break is far away, the detectable warning surface are placed at the back of curb.

Review the Oregon Standard Drawing RD905. Also note, that the detectable warning surface should not be placed across a grade break per the standard drawing Note 5.



**RD905.pdf**  
 237.6 KB



When the detectable warning surface is installed improperly and a flare is present, it becomes possible for a user to walk down a flare and into the intersection without making contact with the detectable warning surface. This is particularly an issue for those with vision impairments. See image below.



Improperly Installed Detectable Warning Surface.  
Pedestrian with Visual Impairments Could Miss Detectable Warning

## Detectable Warning Systems Failure Examples

Scroll through three examples of failing detectable warning surface (DWS) installations. During inspection this is noted as IITD (Incorrectly Installed Truncated Domes) in the Detectable Warning section of the inspection form.





**Example 1: Incorrect DWS Installation. The DWS does not span the full width of the curb ramp opening. DWS should not be stacked with multiple tiles unless directed in the plans by Engineer of Record. Utility lids allowed in the DWS area can accept a liquid applied detectable warning surfacing product to meet the requirements.**

---



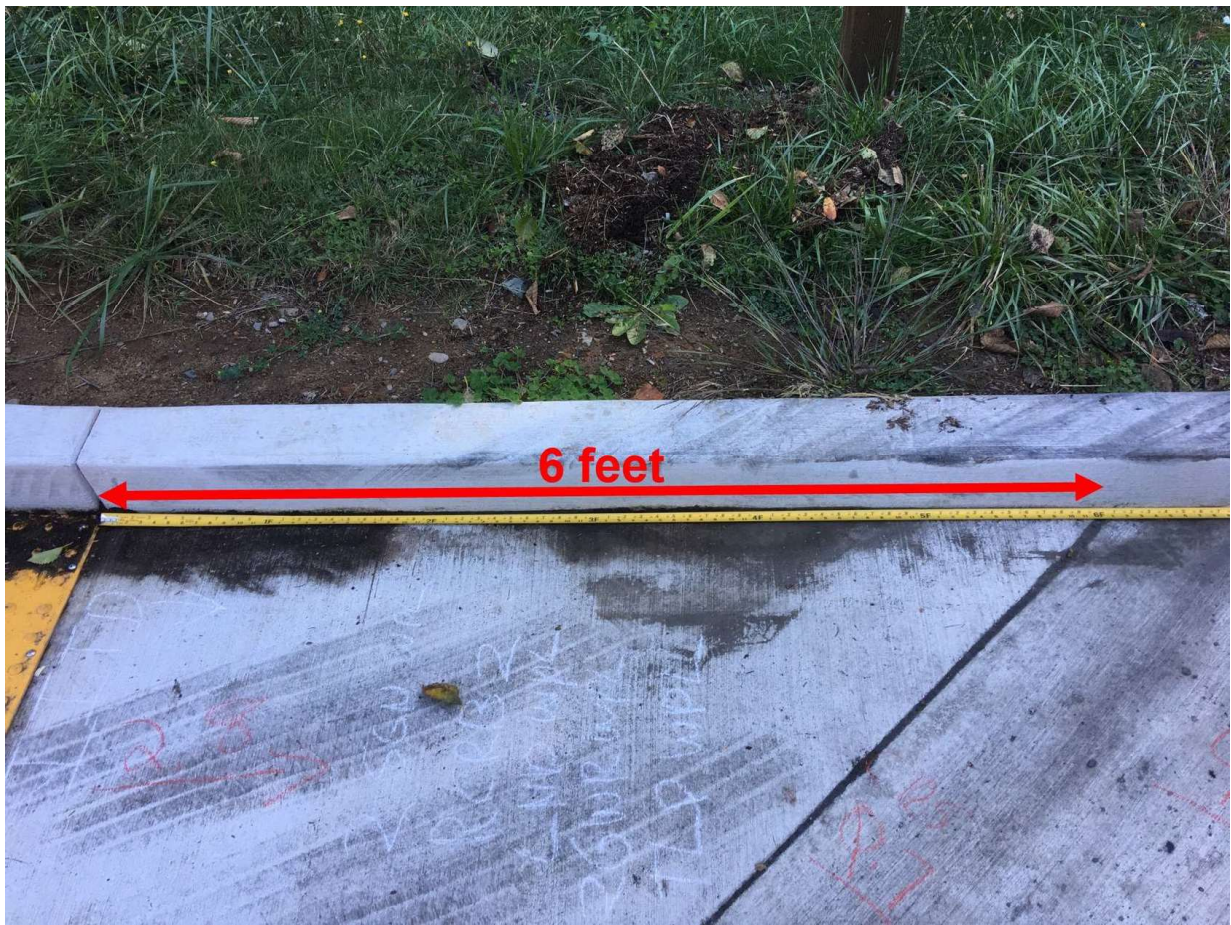

**Example 2: Incorrect DWS Installation. When the longest length of a directional curb is  $> 5.0$  feet, detectable warning surfaces are placed along the curb line. Refer to RD905**

---



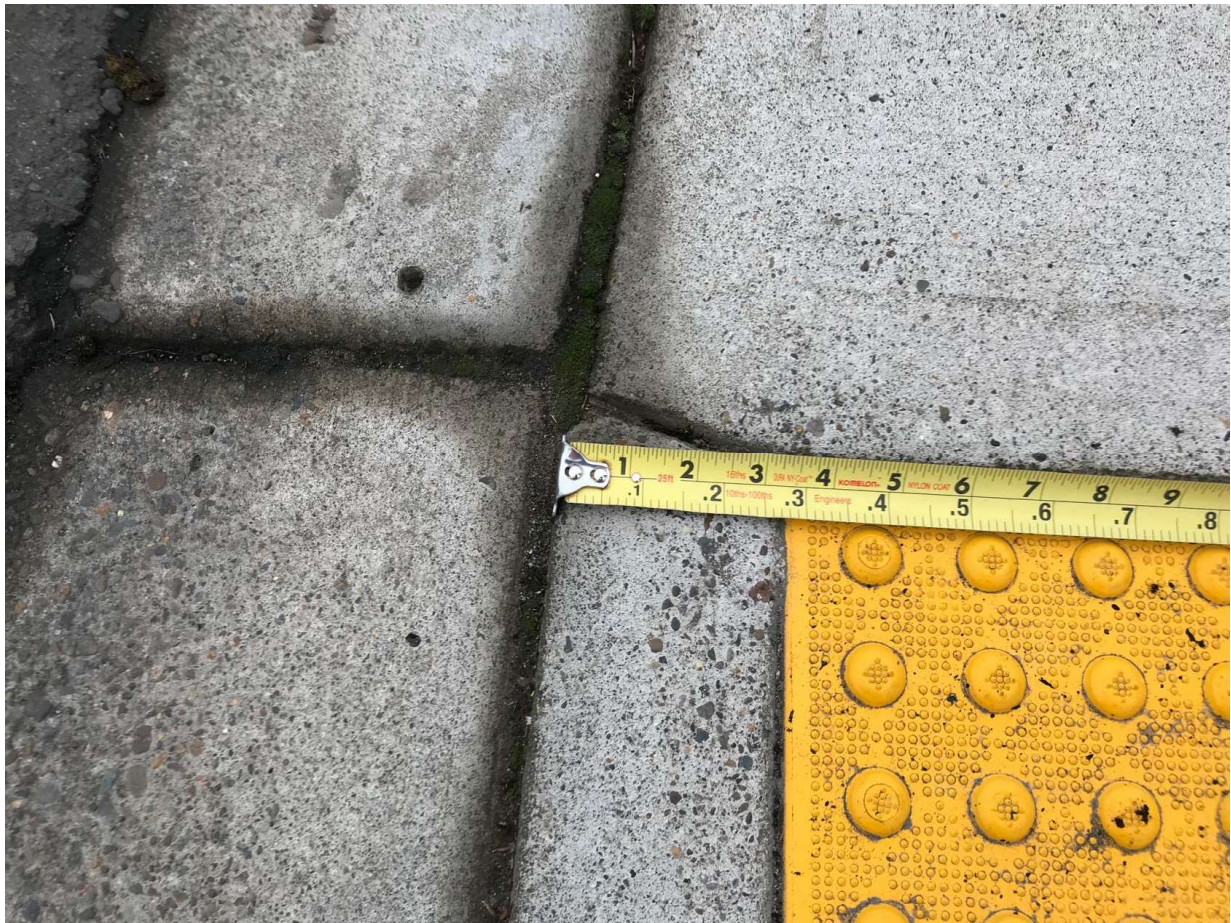

**Example 3: Incorrect DWS Installation. The leading edge of detectable warning surfaces are to be placed within 2 inches of the curb line. Refer to RD902.**

---



01:52

Continue Audio Narration

---

## **Detectable Warning Surfaces for ODOT**

The Oregon Department of Transportation's Structure Services Unit evaluates products to determine their compliance with construction project specifications including detectable warning

surfaces.

Results of these evaluations are published semi-annually in the Qualified Products List, a comprehensive list of all finished products including detectable warning surfaces found to be acceptable by ODOT for use with specific categories in roadway construction.

## ODOT Qualified Products List

This is the list used for ODOT construction projects to identify qualified products.

QPL

## Detectable Warning Surface FAQ's

**i** Q: I don't see the standard drawing allowing the option to stack truncated domes. Has the requirement changed?

A: Yes, ODOT's practice no longer utilizes stacked truncated domes. Reference Oregon Standard Drawing RD902 which details the placement for truncated domes corresponding to ramps.

**i** Q: Are truncated domes required to be placed against the edges of return curbs and at the edge of the back of curb?

A: Reference Oregon Standard Drawing RD902, Note 3 and detail "A". A gap of up to 2 inches is allowed on each side of the detectable warning system.

 **Q: Can the score line at the back of the curb, in front of the truncated dome, be eliminated to prevent spalling of the small gap between the score line and the front of the truncated domes?**

A: ODOT's standard practice does not include monolithic curb and gutter construction with the curb ramp systems. When monolithic construction is specified on the contract plans for curb ramp systems with the adjacent curb, the score line can be eliminated provided the distance from the face of curb to the front of the truncated domes does not exceed the normal curb depth plus the 2-inch gap. Eliminating the back of curb score line will also help with ensuring a smooth consistent surface to improve compliance.



Review all figures, complete activities and advance audio to the end before moving on.

# Unit 6 Lesson 3: Pedestrian Accessible Route Concepts

---



You must click on all images before moving on to next Lesson.



04:24

Start Audio Narration

---

In this Lesson, expanded concepts on pedestrian accessible routes and pedestrian circulation areas will be covered. This includes transition segments to match back into old or existing infrastructure that is not being modified and Clear Width requirements.

## Transition Panels

Transition panels connect new curb ramp construction to the existing, potentially non-compliant sidewalk.

Transition panels warp the cross slope from the existing sidewalk to the new compliant curb ramp system cross slope. The transition is done to provide a smooth connection using a warping

technique. The transition panel must be long enough so that the cross slope should warp at a rate of 0.5% per foot with a maximum allowable warp rate of 1% per foot.

Transition panels are also used to transition the width of the new curb ramp system to match into the existing sidewalk width. The minimum sidewalk width taper rate is 1:3 for horizontal changes.

Transition Panels are not intended to make up grade or elevation changes. It should match the grade of the existing sidewalk and nominally match the road profile. In some cases, the curb reveal may vary at the face of the curb in transition panels to match back into a different curb height. The slope rate should be specified in the contract plans and details. This is not a change in grade along the walkway surface, it is the change that occurs at the storm gutter line.

Transition panels are a part of the pedestrian access route and must be inspected but they are not recorded on the Curb Ramp Inspection Form. Transition panels do not require a design exception, but they cannot be constructed in a manner that make the pedestrian access route worse than pre-existing conditions. See Oregon Standard Drawing RD722 (below) for additional details on transition panels.



**RD722.pdf**  
277.8 KB



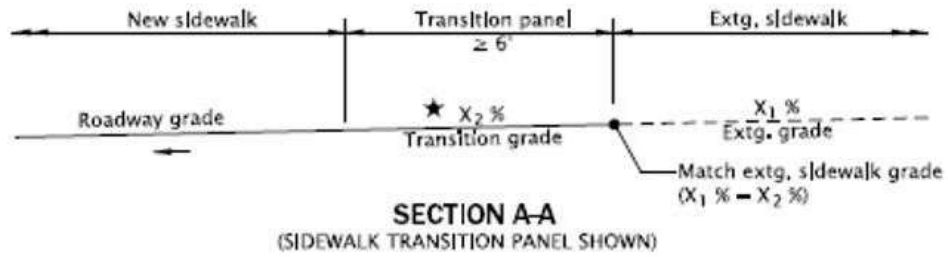

★ Project the existing sidewalk profile grade through transition panel to new sidewalk or curb ramp run.

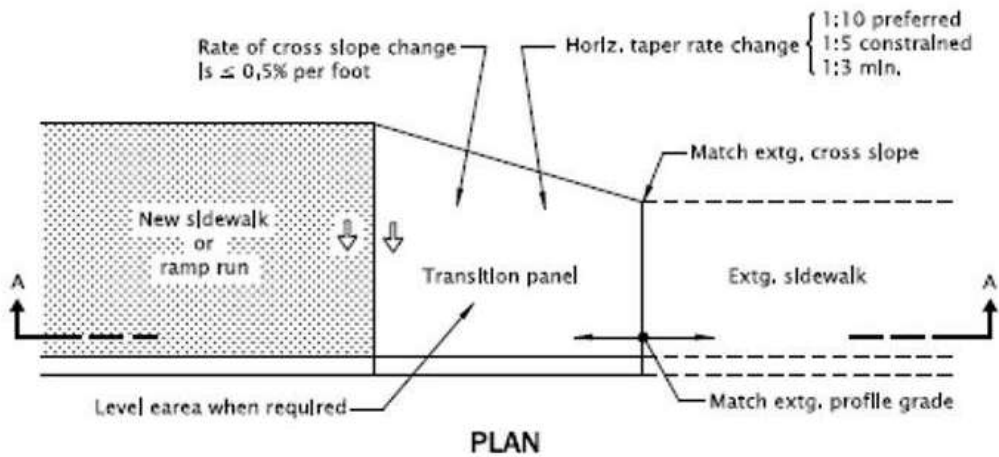
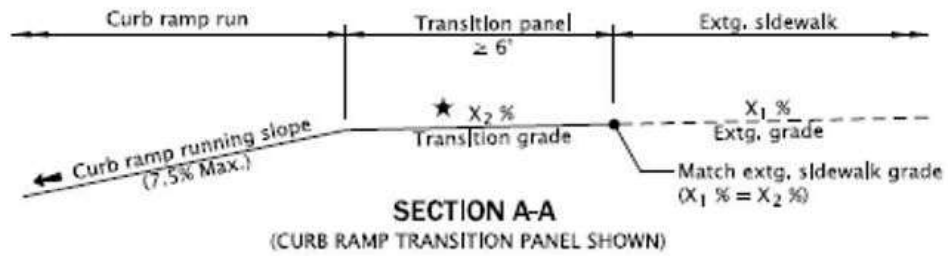

**Source: Standard Drawing RD722**

*Closeup of RD722 Standard Drawing Sidewalk and Curb Ramp Transition Panels*





**Q: Standard Drawing RD722 describes the requirements for transition panels. When a transition panel connects a sidewalk to a curb ramp system, the sidewalk and transition panel are to be the same grade. Is there any tolerance for the transition panel?**

**A: ODOT has not established a tolerance at this time. It is recommended that you use the rules of rounding to the nearest percent to establish a nominal value.**

---

## Clear Width

The clear width is the narrowest width found within the proximity limits of the curb ramp system that is the intended pedestrian accessible route. In general, the minimum allowable clear width in a curb ramp system is 4 feet. However, clear width acceptance varies based on the curb ramp style. The passing and failing criteria for clear width is listed on each curb ramp inspection form. Measure and record horizontal distances to the nearest 10th of a foot for clear width.

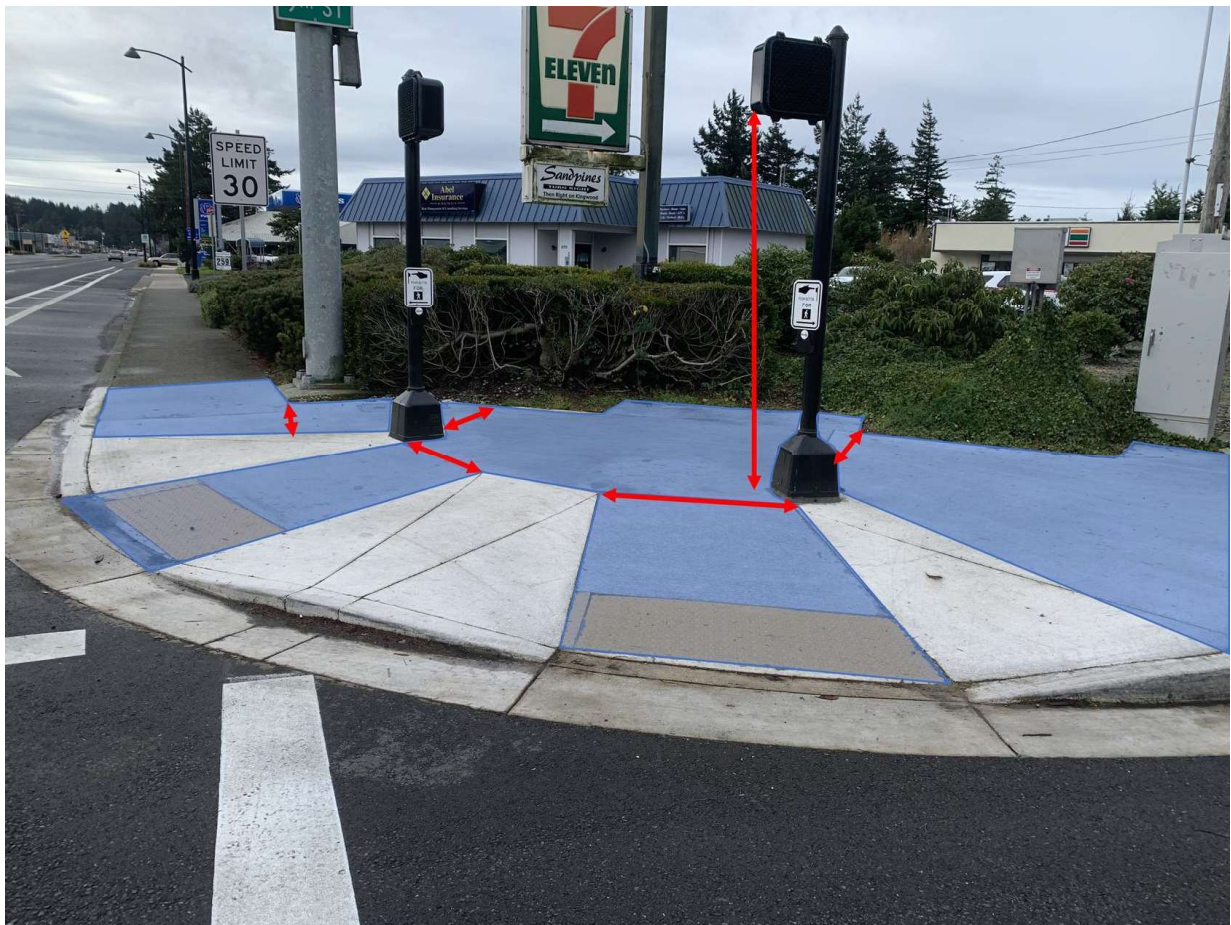

*Possible Clear Width Minimum Measurements within the Accessible Pedestrian Route*

---

Look for obstructions in the clear width, both horizontally and vertically. The clear width shall be at least 4 feet across and 7 feet above the walking surface along the pedestrian accessible route. Objects such as pushbutton pedestals, signals, signs, utility poles, and fire hydrants are frequently in the curb ramp system. There may be a mailbox projecting into the clear width or guywires above the walkway. These could be the controlling feature for the clear width measurement. Clear widths in the pedestrian access route must have a cross slope of 2.0% or less at finished construction unless there is an approved Design Exception (DE).

Transition panels are not recorded on the curb ramp system form as it is only temporary connection until the next segments of walkway are altered. The picture below illustrates an

example of clear width measurement locations that are necessary to find the smallest value to be recorded on the inspection form.

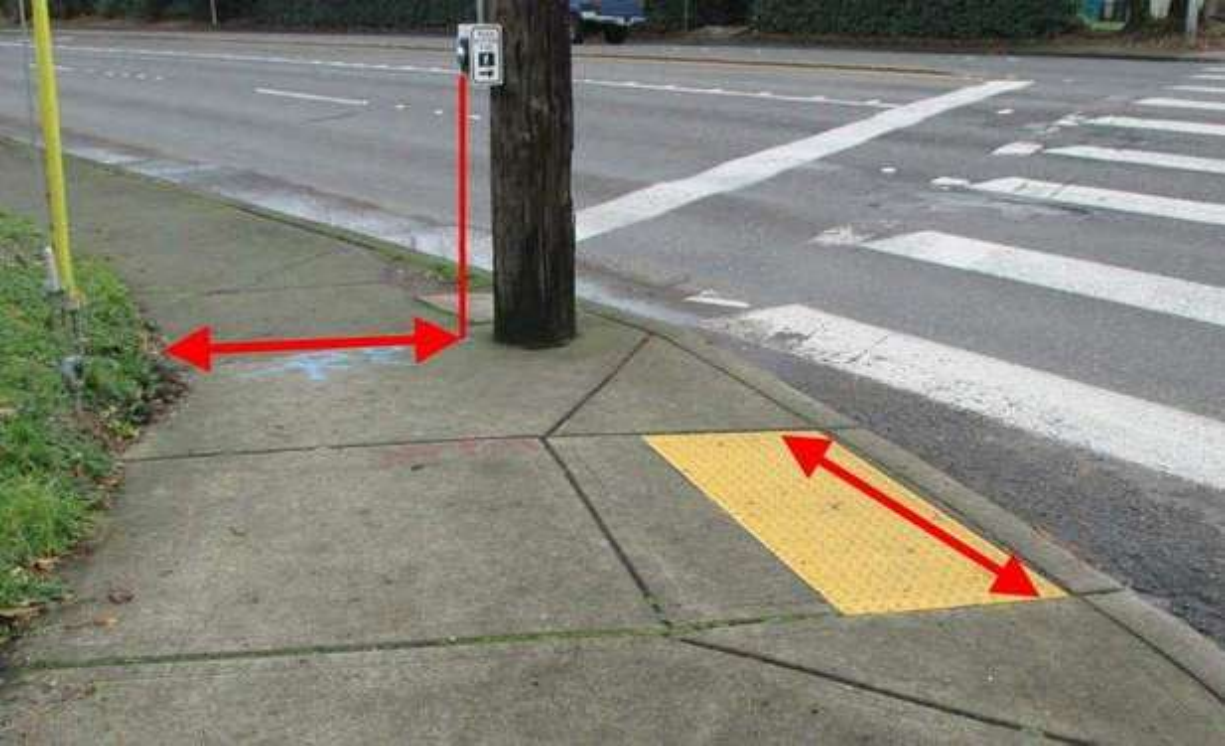

*Example of Clear Width Measurement Locations*

---

**Activity: Clear Width Obstructions**

Drag and drop the items that are considered to be either a clear width obstruction or not a clear width obstruction.

Clear Width Obstructions

---

**Signs**

**Railings**

**Mailboxes**

**Fire Hydrants**

**Guy Wires**

**Communication Boxes**

**Bike Racks**

**Planter Boxes**

**Guardrails**

**Vertical Curbing**

**Retaining Walls**

**Cross Slope Surfaces  
Exceeding 2.0%**

**Not Clear Width  
Obstructions**

**Moveable Trash Cans**

**Moveable Advertising Stands**



**Review all figures, complete activities and advance audio to the end before moving on.**

## Unit 6 Lesson 4: Lips and Gaps

---



**You must click on all images before moving on to next Lesson.**



01:59

Start Audio Narration

---

### Lip Height

Flush connections are required in a curb ramp system and the walkway's pedestrian access route. ODOT inspects and records this information in the box noted as a "lip". A lip is a vertical discontinuity along the pedestrian access route or sidewalk. Lip height is the vertical difference between two adjacent surfaces measured within the curb ramp proximity limits. Lip heights are recorded when the surface slopes that meet at a grade break are not flush.

Lips can occur from many causes including differential settlement of concrete panels where two different surfaces meet and with poor construction methods. Lips can be found anywhere within the curb ramp system proximity limits including ramp runs, level areas, turn spaces, and transition panels on the sidewalk. Grade breaks shall also be flush with no lips.



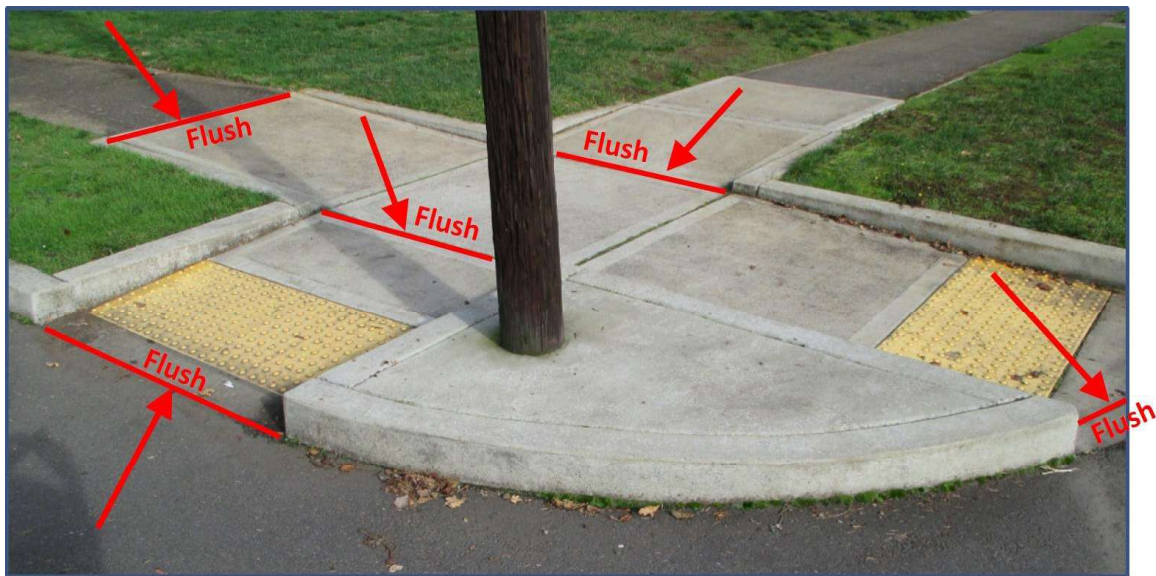

*Possible Areas Where Lips May Occur on a Curb Ramp System*

---

## Measuring Lip Height

When measuring lips, you will need a straight and level edge tool, and a metal measuring tape. There are tools available on the market that can make inspecting for lips easier with a specialized template for ADA compliance that can fit in your pocket. You may also use other tools such as your smart level or a carpenter's square. Lips can be found anywhere in the proximity limits. Look for them at the front of gutter or the front/back of curb. After the measurement is completed always round up to specified values.

- For lips that are equal or less than 1/4-inch, round down to 0.
- When greater than 1/4-inch, round to 1/2-inch.
- There is a drop-down list in the inspection forms for lip values. They are 0, 1/2-inch, 1-inch, 2-inch, 3-inch, and 4-inch. Round up to the nearest values.

Here are some real-world examples of lips that have been encountered in the field showing lip failures in construction. Newly constructed curb ramps systems shall not have any lips upon



completion of construction.

Expand each of the boxes.

### Measuring Lip Height —

Gutter lip must be flush. (See RD910, RD920, RD930 & RD940) Otherwise ramp will not pass inspection and will be rejected. Note that the ramps in this photo would FAIL. See standard drawings for additional details.

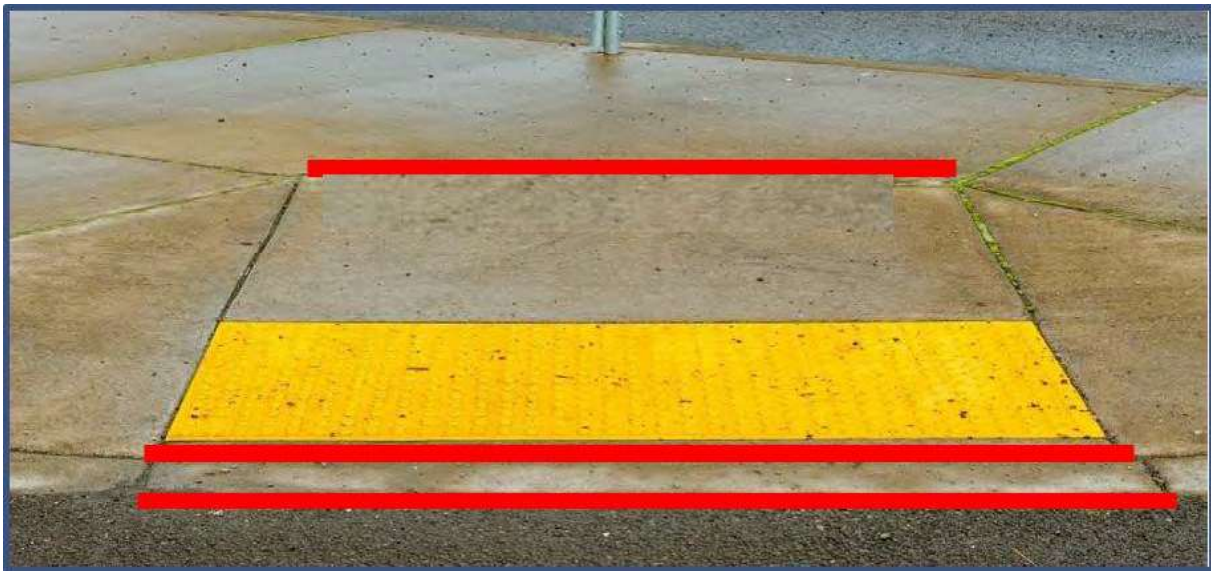

### Lip Height Example 1 —

Gutter lip must be flush. (See RD910, RD920, RD930 & RD940) Otherwise ramp will not pass inspection and will be rejected. Note that the ramp in this photo would FAIL. See standard drawings for additional details.



### **Lip Height Example 2** —

Gutter lip must be flush. (See RD910, RD920, RD930 & RD940) Otherwise ramp will not pass inspection and will be rejected. Note that the ramp in this photo would FAIL. See standard drawings for additional details.



04:35

Continue Audio Narration

---

## Gaps

Horizontal gaps along a surface that are an accessibility issue are also considered lips. A horizontal gap in the pedestrian access route or walkway can make it difficult for a wheelchair to traverse the surface. If the horizontal gap (flush or not), exceeds 1/2 inch, record the information in the "lip" data field with a comment in the Curb Ramp Inspection Form.

Gaps can result from poor concrete mixes, poorly compacted underlying foundations, improperly tooled joints, and wide expansion joint fillers. Hairline concrete cracking is not an accessibility issue. **If you are inspecting a newly constructed curb ramp system, there should be no gaps.**

## Measuring Gaps

You will need a measuring tape or ruled device to measure horizontal gaps.

Note that gaps that are greater than ½ inch wide are recorded as lips on the inspection form, even though we understand that a void is not really a vertical surface discontinuity (Lip).

If you are recording a lip that results from a gap, make note in the comments section. This will be discussed in more detail in Unit 9.

## Expansion Joint Installations that Create Lips or Gaps

Expansion joints within the curb ramp system are to be flush and less than ½ inch width along the top finished surface. When not installed correctly in curb ramp systems, they become an accessibility issue within the pedestrian circulation area or the pedestrian access route.

Expansion joints that are not flush or greater than ½ inch width should be noted in the standard comments section of the curb ramp inspection form.

Expansion joints should not be placed within the limits of the curb ramp system area (see RD722, note 5) but they are required to be around poles, utility boxes, pushbutton foundations, at the ends of each driveway and other fixtures which protrude through or against the sidewalk concrete structure (see RD722, note 5). Expansion joint material may be of variable size based on the contract details.

Often utilities fall within the vicinity of curb ramps systems. For example, junction boxes or manholes with vertical grade changes (lips) can reduce the clear width that is accessible. Utility

covers must be flush when they are installed in the pedestrian walkway. Review the plans and specifications for slip resistant covers or other accessible covers when they are specified. Note utilities in the comments section of the inspection form using standard comment format.

Curb ramp systems are sometimes constructed on a bridge end and integrated with the bridge construction. Expansion joints located on a bridge structure will require more specific design details to ensure the pedestrian access route meets ADA requirements. Review the drawing details and the manufactures installation requirements carefully. This is discussed more in the later unit on advanced topics for inspection.



Expansion Joint  
Gap Failures



Expansion Joint Lip  
Failures

## Lip FAQ's

 Q: Can a ¼-inch lip be constructed at grade breaks?

A: No. Reference many of the Oregon Standard Drawings in the RD900 series, which states “Surface slopes that meet at grade breaks shall be flush”.

**i** Q: Can the bottom of the ramp have a ¼-inch lip, at the intersection of the ramp and gutter line?

A: No. Reference many of the Oregon Standard Drawings in the RD900 series section A-A, which references Gutter zero lip.

**i** Q: Is there any guidance on the width of gaps? Will any gap between panels fail a ramp?

A: Gaps that are over ½-inch wide will fail a curb ramp system and are recorded on the curb ramp inspection form. Gaps are recorded in the lip section of the inspection form with the addition of a non-standard comment in that section of the form.

**i** Q: Is there a conflict with Standard Specification 00759.44 for expansion joints?

A: The 2024 Oregon Standard Specification for Construction indicates unless shown or directed otherwise, a minimum of ¾ inches expansion joint is constructed between new and old concrete. Oregon Standard Drawing RD722 details the ½-inch expansion joint for walkways. The Standard Drawings take precedence over the Standard Specifications according to Standard Specification 00150.10. The ½-inch width in the pedestrian access route is the correct value supported by the order of precedence. Other concrete structures covered under 00759 that adjoin new and old concrete may need to be built according to the specification.