



INSTALLATION MANUAL

FOR USE WITH MODEL #s
MICROFAST 0.5, 0.75, 0.9, 1.5 (NSF STD. 40 CERT.)

BIO-MICROBICS, INC.
FAST®
WASTEWATER TREATMENT SYSTEMS

IMPORTANT: *All work must conform to local electrical plumbing, and building codes.*

TABLE OF CONTENTS

Materials Required for Installation	2
Important Information.....	2
Location	3
Delivery Inspection.....	3
Process Description.....	4
The FAST® System.....	4-5
Recommended Installation Procedure.....	5-11
Module Installation	5-9
Blower Hookup	9-10
Electrical Hookup	10-11
Control Panel Alarm Test	11-12
Final Installation Inspection.....	12-13
Evaluation of System Performance.....	13
System Failures.....	13-14
Mechanical Failure	13
Electrical Failure	13
Process Failure.....	13-14
Troubleshooting Guide	14-16
Warranty.....	16
FAST® Installation Components Diagram.....	18
Wiring Diagrams.....	19-21
Index	22

MATERIALS REQUIRED FOR INSTALLATION

1. Septic tank with minimum dimension requirements shown on installation drawing and fabricated according to IAPMO, ANSI or appropriate standards.
2. Recognized, safe lifting mechanism for module.
3. Concrete joint sealant compound **SUPPLIED WITH UNIT**. This is a silicone based sealant manufactured by GE. Construction mastic is an acceptable alternative.
4. Anchor bolts or other commercially available anchoring system to secure module to septic tank and blower housing to concrete base.
5. 2 (air line) & 4"(water lines) PVC Sch 40 and 6"(venting) PVC Sch 35 (or Schd 40) pipe and fittings. Optional: 3" PVC Schedule 40 pipe and fittings (venting) (see Recommended Installation Procedure concerning venting).
6. PVC saw
7. Pipe joint lubricant/soap.
8. PVC primer and glue.
9. Base (concrete preferred) for blower assembly.
10. Mounting screws for control panel.
11. Electrical underground conduit and fittings and wiring for connecting control panel to blower assembly and facility's master panel.
12. Hammer Drill and concrete bits (if unit is not already mounted in the tank).

IMPORTANT INFORMATION

One or more of the following patents protects this process: 3,966,599; 3,966,608; 3,972,965; 5,156,742. Please read and follow the cautionary notes given below and those found elsewhere in this manual. If you have questions regarding the safety or operation of your FAST® Wastewater Treatment System, contact Bio-Microbics, Inc. at:

1-800-753-FAST (3278)



WARNING: *The installer must assure that the installation site is safe from hazards. These could include excavations left open overnight, debris left lying around, and tanks and equipment not properly blocked. Provisions must be made to eliminate the above potential hazards by roping off and proper shoring around the excavations, cleaning up at the end of each work day and proper storage of equipment. Failure to do so could result in severe bodily injury or death.*



WARNING: *Hazards exist in confined spaces such as a new or used buried septic tank. No one should be allowed to enter the tank under any circumstances. The hazards include presence of dangerous or fatal gases, insufficient oxygen, and the collapse of the tank and entrapment of personnel. Always keep tank openings covered during storage and installation. Failure to do so could result in severe bodily injury or death.*



WARNING: *If any person comes in contact with any of the wastewater (influent or effluent), immediately remove all contaminated clothing and soak in a detergent solution with a disinfectant. The person who has come in contact with the wastewater should then thoroughly wash the exposed area with soap and water and immediately call his or her personal physician. Failure to do so could result in severe bodily injury or death.*

LOCATION

The FAST® systems may be located in the same position relative to the house and water supply as any conventional septic system; however, some basic guidelines should be followed:



WARNING: *Always check with the local utility companies for the location of water lines, electrical and telephone cables or any additional hazards below grade prior to excavation. Failure to do so could result in severe bodily injury or death.*

1. The FAST system cover is only designed to withstand the weight of the soil up to a burial depth of 4 feet (1.2 meters). It is not designed to withstand loads from concrete slabs, vehicles, or buildings. Do not place the tank in a location where it could be subjected to additional weight.
2. The FAST system must be located so that sufficient slope is provided for the influent and effluent lines. If either of these two lines becomes blocked, there is risk of excess water backing up into the house. A 2% slope is recommended for this. A 2% slope equates to a drop of two feet over a run length of one hundred feet. This also equates to 1/4 inch per foot.
3. The FAST system must be located so that vents and air intakes will be protected from snow drifts.
4. Avoid locating The FAST system in high groundwater areas where the tank could possibly float up and become dislodged.
5. The blower housing should be no more than 100 (30.5 meters) feet from the FAST system.
NOTICE: *The blower must be placed at an elevation higher than the flood plain. If the blower or vent pipe is being placed next to the building or home, choose a location away from windows or doors.*
6. FAST can be installed hanging from the tank lid, or standing on feet off the bottom of the tank. If FAST is not mounted in the tank prior to site installation, then verify that the outlet is in the proper place (15" on center down from the bottom of the FAST module's lip). When installing a new septic tank, make sure the inlet is a minimum of 2 inches (5.08 cm) above the outlet (or per local codes).

Documentation must be maintained by installers verifying the minimum dimensions of the tank as well as its structural integrity. If the tank is smaller than the minimum dimensional range specified, the FAST system will not operate properly. The effluent quality could suffer and may not meet the standards.

DELIVERY INSPECTION

The FAST system has been carefully manufactured, checked and tested at the factory before shipment. Upon receiving the unit, please do the following:

1. Before uncrating, check the packaging for signs of shipping damage. If there is evidence of damage or abuse, notify Bio-Microbics, Inc. at (913) 422-0707.
2. After uncrating, inspect the unit to ensure no components are missing. Also inspect for damage to the unit. If any discrepancies are found, notify Bio-Microbics, Inc. at (913) 422-0707.

PROCESS DESCRIPTION

The primary treatment zone can be called the anaerobic zone and is the area from the inlet to the septic

tank baffle. In this zone, primary settling takes place. Heavy solids will readily settle out. Most suspended solids in wastewater are “sticky” and flocculate naturally. The flocculation will aid the suspended solids in settling. In the primary treatment zone, there is no chemical coagulant usage or mechanical mixing to aid in flocculation. There is no type of skimmer in the primary zone to remove greases, oils or foam. Any floating material is prevented from passing from the primary to the secondary zone by placing the inlet to the secondary zone 24 inches above the floor of the tank.

Several biological processes and physical operations take place in the secondary treatment zone or aerobic zone of the FAST system. The oxygen and food plus the circulation of the fluid allow biological cells to grow and attach themselves to the fixed media.

Because of the wide variety of organics in the waste stream, a wide variety of organisms or a *mixed culture* biomass is formed. The most predominant biological reactions involve the degrading of organic matter such as proteins, carbohydrates, and lipids to carbon dioxide.

Once the biomass has established itself, several external factors may affect the rate of biomass reproduction and food utilization. The rate of biomass reproduction generally increases with increasing temperatures within the range of 0° C (32° F) to 32° C (90° F). The biological reaction rate increases with increasing temperatures. A rule of thumb for this rate is the reaction rate will double with every 10° C temperature increase up to a maximum temperature of 32° C.

The microorganisms that degrade the wastewater organics function best in the pH range of 6 to 9. This is the typical pH range of domestic waste, but it should be verified.

Although the micro organisms are capable of adjusting to a wide range of environmental factors, sudden changes and shocks may damage the existing biomass.

The physical operations that take place in the secondary treatment zone are the aeration and circulation of the wastewater by a blower and airlift. This is a method of providing the biomass with a continuous fresh food and oxygen supply.

THE FAST SYSTEM

FAST stands for Fixed Activated Sludge Treatment. In the FAST process, a colony of bacteria called the biomass breaks down biodegradable waste into carbon dioxide and water. The process occurs continuously as long as the biomass is supplied with food (incoming waste) and oxygen (air) in a suitable environment. Solid material that the biomass cannot process and bacteria that die settle in the septic tank for normal pump-out removal.

The FAST process consists of the treatment tank and the blower (air source). The blower provides continuous air to the treatment tank through the air supply pipe. The air supply pipe combines with the draft tube to create an air lift. This air lift is the means by which air and wastewater are mixed within the tank. The air lift lifts the wastewater to the splash plate. The wastewater is cascaded off the splash plate across the surface of the honeycomb media.

The honeycomb media is the heart of the FAST process and is suspended in the septic tank. The media contains the biomass, the colony of bacteria that stabilizes the wastewater. By growing on the honeycomb media and receiving food and air necessary for growth from the airlift, the biomass is allowed to stabilize (eat) the waste before it is discharged to the drain field. In a traditional septic tank and some other aerobic treatment systems, the biomass is allowed to suspend in the wastewater. Therefore, it has a greater opportunity to be discharged into the drain field. The Fixed Activated Sludge Treatment system keeps the active biomass on the media and not in the water. This allows for cleaner water to be discharged to the

drain field.

The vent pipe allows for venting of air and non-harmful carbon dioxide created by the process.

Eventually, as the biomass dies, sloughs off the media and collects at the bottom of the tank, the tank will need to be pumped out.

The treatment tank is located below ground. Its rugged construction is designed to support the weight of four feet of burial depth. It is designed to resist deterioration and corrosion.

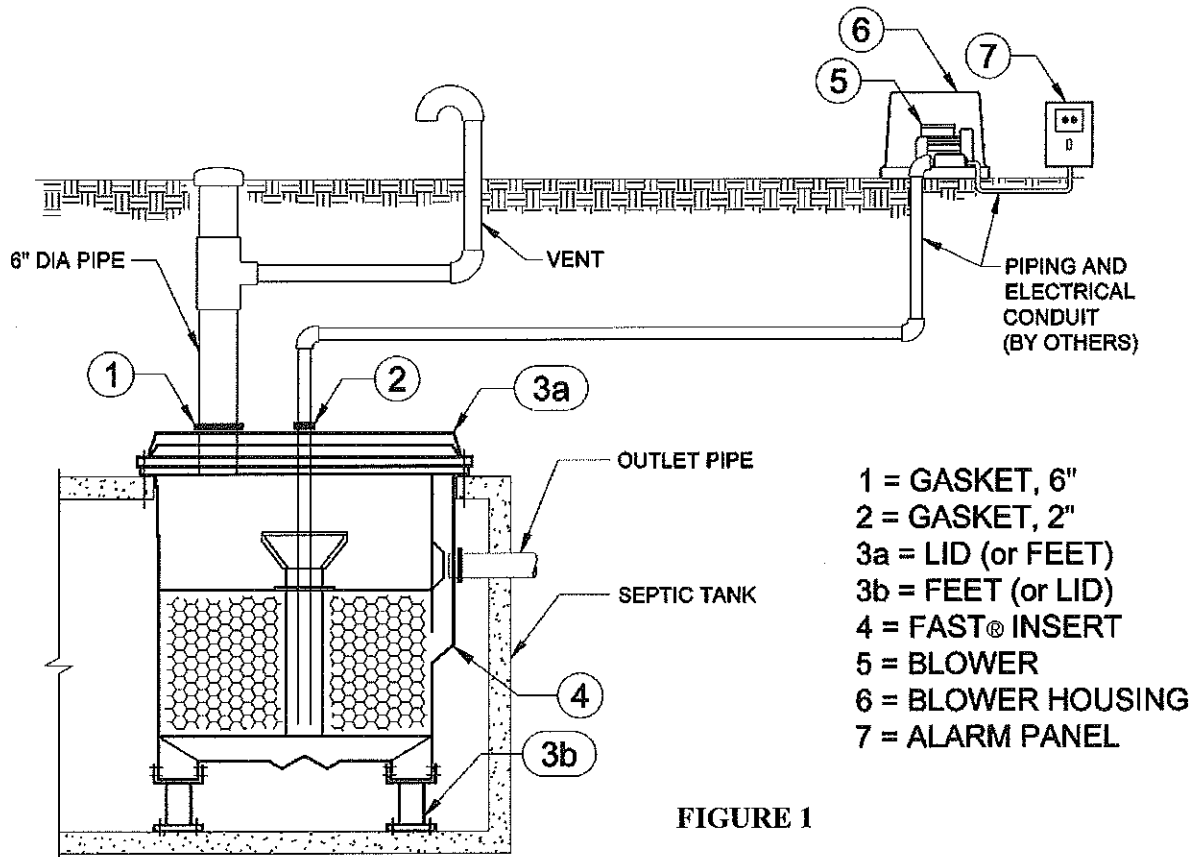

FIGURE 1

RECOMMENDED INSTALLATION PROCEDURE

The disposal method of the effluent wastewater can influence the performance of this unit. The method and arrangement for disposal must not cause a backup or any other interference with the treatment plant's operation. The technique and equipment used for the effluent disposal must be approved by the local or state health and environmental agencies.

Bio-Microbics highly recommends that installation contractors perform a quality installation of all parts of the sewage system.

Before installation of the module may begin, check the tank to ensure it is level within 1 inch from inlet to outlet and 1-1/2 inch from side to side.

Once the tank is in place, level and in compliance with local health, environmental and plumbing regulatory agencies, the installation of the module may begin.

MODULE INSTALLATION



WARNING: Use recognized, safe lifting techniques to set module in tank. Make sure all lifting equipment is clear of overhead obstructions such as power lines, trees or rooftops when lifting apparatus near the excavation. Always be careful. Place the lifting equipment on solid, stable ground to prevent the ground from giving away beneath the equipment.

Approximate weights of FAST modules:

MicroFAST 0.5	200 lbs
MicroFAST 0.75	250 lbs
MicroFAST 0.9	300 lbs
MicroFAST 1.5.....	350 lbs

There are two options available for inserting the FAST module into the tank. Option A utilizes the module lid to anchor the module into the tank. Option B utilizes leg extensions to stand the unit inside the tank. Either option can be used.

1. **Option A: LID INSTALLATION** – Place module liner through hole in top of tank. Place module lid on top of module liner. Carefully line up the air line hole in module lid with coupling at top of draft tube inside module insert. Make sure the airline pipe stands perpendicular to the lid.
 - a. Use a hammer drill to the drill holes for anchoring the module to the tank using pre-formed holes in the module lid.
 - b. Apply sealant to mating surface between module liner and module lid. Position module lid on top of module liner and secure module lid and liner to tank, using holes drilled in step 2 and stainless steel anchor bolts at least 2" long.
 - c. Bevel and soap the end of a 6" Sch 40 PVC pipe to be used as observation port/vent. Insert 6" factory provided gasket into observation port access hole in module lid. Insert pipe until it stops, which should be ~2" inside module lid. (DO NOT PUSH

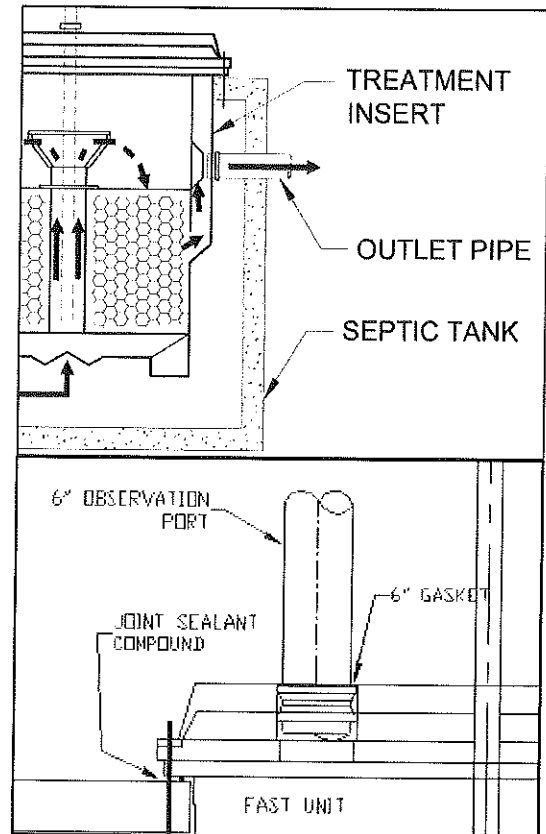

FIGURE 2 A&B

ALL THE WAY DOWN TO MEDIA SURFACE!)

2. **Option B: LEG EXTENSIONS** (See FIGURE 3 shown below) – Four leg extensions attach to the 4

corner feet of each module. The leg extensions are attached to the feet of the modules using 8 self-tapping screws. For the 0.5 model only, 4 self-tapping screws are provided for each leg extension. Two methods exist to fix the module in place once the leg extensions have been attached and the module has been inserted into the tank.

- a. The leg extensions are attached to the base of the tank with anchor bolts. Only 2 anchor bolts are required for each leg extension. The recommended pattern for placement of the anchor bolts is in the 2 corners diagonal to one another.
- b. If the tank is too small for a person to get inside with the unit to anchor bolt the leg extensions to the floor, stainless steel brackets may be used to attach the flange at the top of the liner to the tank (see Figure 2.B).

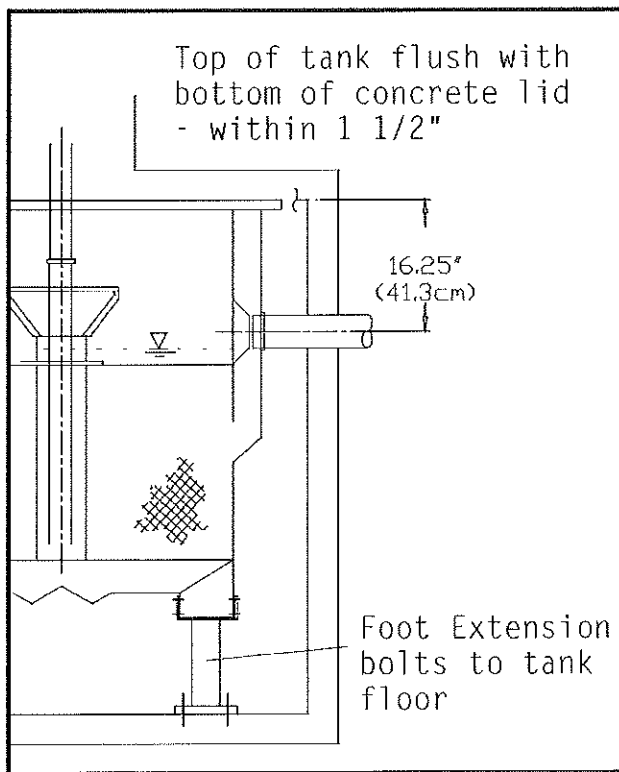

FIGURE 3

This will provide a watertight seal around the outlet pipe on the FAST module. You will also need to provide a water-tight seal around the outlet pipe where it exits the tank.

5. Cut a piece of 2" Sch 40 PVC pipe to be used as the airline entering the module lid to the desired length (or longer). Bevel and soap the end of 2" pipe. Insert 2" factory provided gasket in airline hole in module lid. Insert beveled and soaped end of pipe through module lid. Using 6" hole in module lid, reach inside module and thoroughly clean all pipe soap from the lower 6" of airline or leave cover up off liner to have access to clean and glue the pipe. When complete, slide the cover down the pipe to the liner. Using PVC primer and glue, secure airline into coupling at top of draft tube in module insert. (Be sure to follow instructions on PVC primer/glue container(s). If cover was left up, slide it down on the pipe to the liner. Run this 2" pipe to the desired blower location.

NOTE: The leg extensions may be adjusted in height up to 24" to increase the overall clearance between the floor of the tank and the bottom of the module. This is accomplished by cutting the leg extension in half and sliding a 4" Sch 40 PVC pipe over the bottom and top piece of each leg extension, then the base of the leg extension is attached to the bottom of the tank as described above, and the top of the leg extension is attached to the foot of the module also as described above.

3. Remove module lid and lift module liner to apply sealant between mating surface of module liner and top of tank (any readily available, non-hardening sealant on job site that will provide a water-tight seal is appropriate).
4. Bevel and soap the end of 4" Sch 40 PVC pipe to be used as effluent/outlet line. Insert through side of tank and into 4" gasket in outlet hole on module. Push pipe in ~ 2" until it stops. **(DO NOT USE EXCESSIVE FORCE WHEN INSERTING THE OUTLET PIPE INTO FAST MODULE!)**

NOTE: When leg extensions are used, the air supply line must be secured to the access riser as shown in FIGURE 3 below.

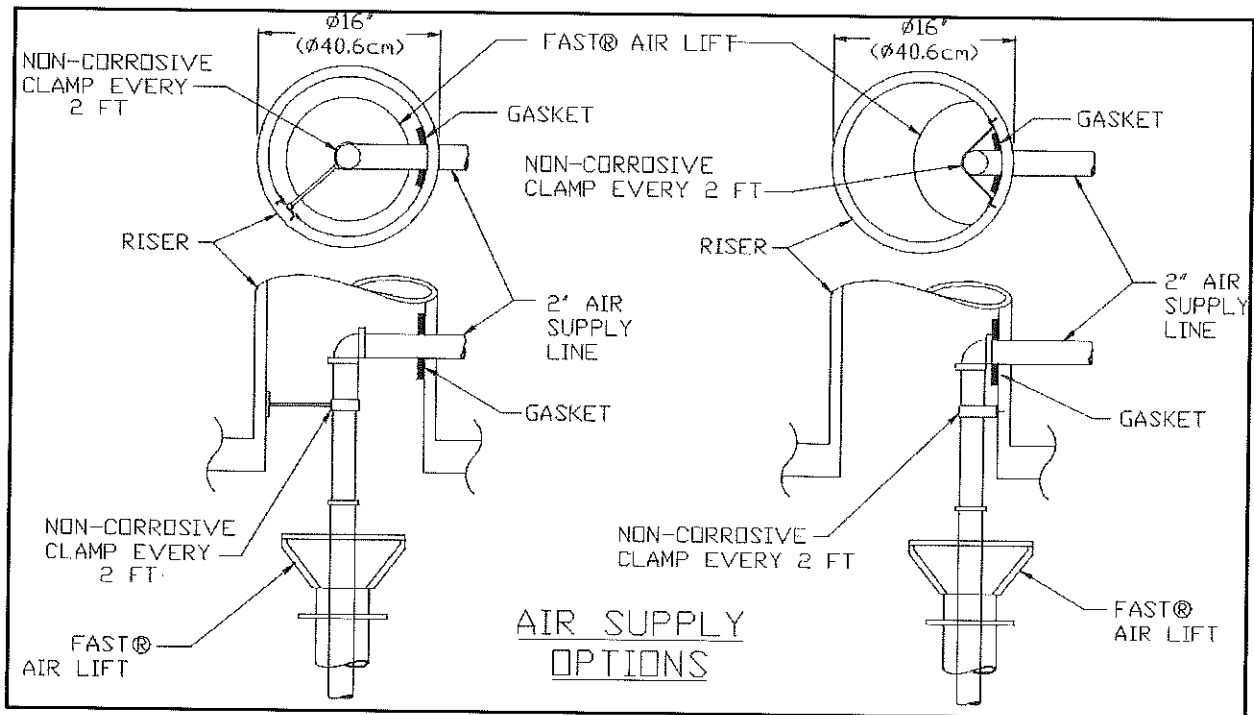

VENTING OPTIONS: When venting the FAST treatment module, installers have three options.

OPTION A -- Direct venting utilizing the observation port/riser installed directly above the unit. **OPTION B** -- Remote venting, which gives the homeowner versatility to have the FAST system vented in a remote area. **OPTION C** -- Venting into a below grade chamber. Regardless of which option is used, the vent piping and vent openings must be sized properly to avoid excessive back pressure in the system (see table below for proper vent sizing).

Minimum Vent Pipe Size Per FAST Unit Size	
- 0.5, 0.75, 0.9 =	3" vent pipe
- 1.0, 1.5 =	4" vent pipe

- OPTION A:** If the observation port/riser is located in a suitable area, not subject to local flooding, this port can double as the vent for the system. (See diagram at right) Reference the above chart for proper vent size. Vent opening should be constructed so that animals and debris cannot enter the system. Cut pipes to length. Use 6" grate with at least 7.1 in² of open surface area. **DO NOT GLUE GRATE ON!** Fasten with stainless steel screws.

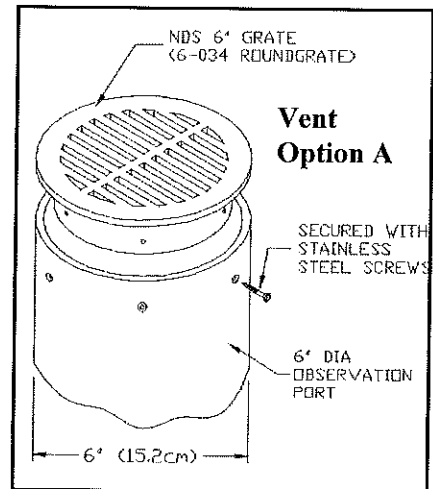

NOTE: For MicroFAST® 1.5, vent grate must have at least 9.1 in² of open surface area.

- OPTION B** (shown below): Cut off 6" observation/vent port about 6" below grade. Run a separate 3" Sch 40 PVC vent pipe under-ground to the desired vent location and cover opening with screen. Glue the 3" pipe to the 6" pipe. Water will accumulate in the vent line when using this option. **The water in the vent piping MUST be allowed to drain to prevent back pressure.** This is most commonly achieved by having the vent line drain back to the 6" observation port. NOTE: For MicroFAST® 1.5, vent line must be at least 4 inches in diameter.



WARNING: Always check with the local utility companies for the locations of water and gas lines, electrical and telephone cables or any hazard below grade prior to excavation. Failure to do so could result in severe bodily injury or death.

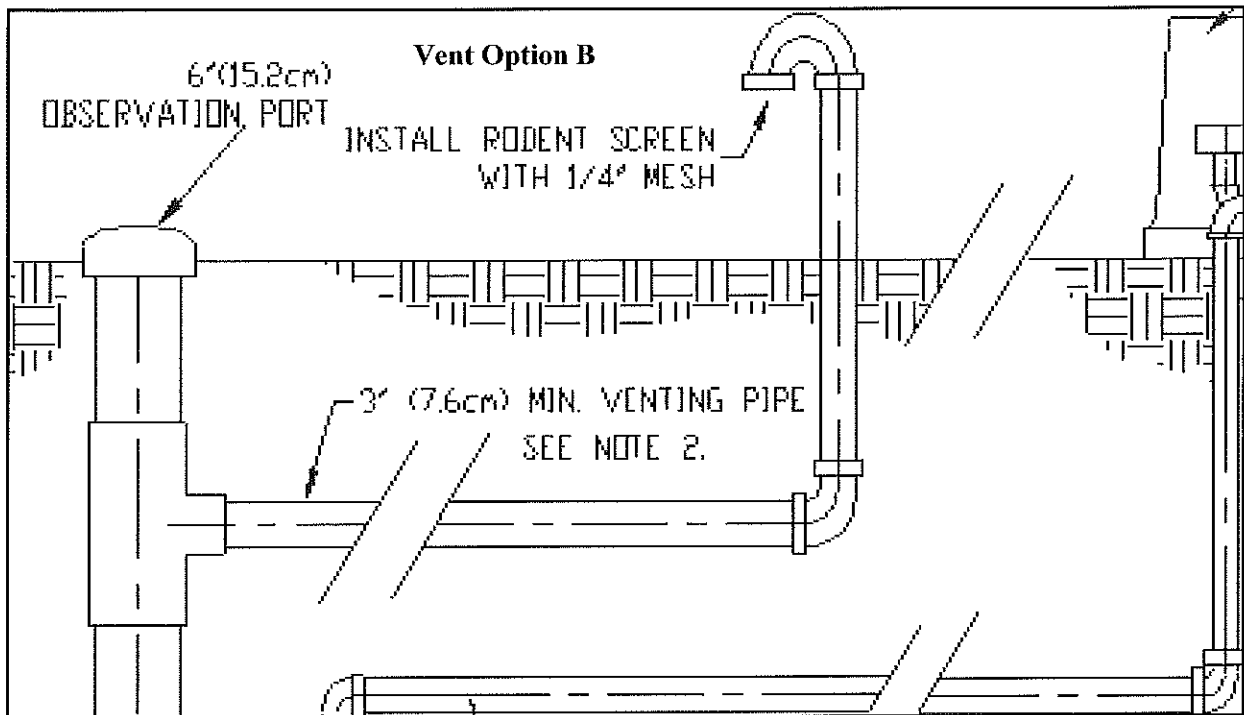

- OPTION C:** The other venting option is to vent into a below grade chamber. For some installations, this option extends the vent into the actual leach field. By venting into the actual leach field, there is the added opportunity of providing additional aerobic activity to the soils. This method may require specific design by a qualified engineer. **CAUTION: Below grade leach field venting can only be done if there is no chance of siphoning the leach field moisture back into the treatment module.**

BLOWER INSTALLATION

The blower housing should be placed on a concrete slab. Both the electrical conduit and air supply line should pass through the concrete slab from below grade. The electrical supply conduit should be run from the control panel to the desired blower location. A precast concrete slab can be used by drilling the appropriate holes for the air supply line. The blower should not be placed more than 100 feet from the unit and should have no more than 4 elbows installed in the air line. Electrical components should not be placed more than 150 feet from the unit.

BLOWER INLET ASSEMBLY: (All fittings below are factory provided)

- A. Screw a 1" x 5" galvanized nipple into the "inlet" port of blower.
- B. Screw a 1" galvanized elbow into the nipple.
- C. Screw inlet filter assembly into elbow.
- D. Inlet piping is now complete.

NOTE: USE TEFLON SEALANT TAPE ON ALL PIPE CONNECTIONS.

3. BLOWER OUTLET ASSEMBLY: (All fittings below are factory provided)

- A. Screw a 1" x 5" galvanized nipple into the "outlet" port of blower.
- B. Screw 2" x 1" PVC reducer bushing onto nipple.
- C. If a flexible coupler is to be used (highly recommended), install it on to the end of 2"x1" reducer.
- D. Outlet piping is now ready for hookup.

NOTE: USE TEFLON SEALANT TAPE ON ALL PIPE CONNECTIONS.

4. Secure blower assembly to base using four (4) 14# x 1½" self-tapping screws (supplied w/ unit). Drill screws directly into blower base.
5. Connect the air line to blower outlet assembly, using PVC primer and glue. (Be sure to follow instructions and PVC primer/glue container(s)). It is recommended that a flexible union (such as a FERNCO coupler) be placed in this line for ease of disassembly. **BE SURE THAT ALL CONNECTIONS ARE AIR-TIGHT AND PERMANENT!** Care should be taken to keep all dirt and debris out of air line assembly!
6. For instructions regarding the connection of the airline to the FAST module, please refer back to **MODULE INSTALLATION** on pages 6-9.

ELECTRICAL INSTALLATION



WARNING: *All electrical work should be performed by a qualified electrician and per all applicable codes. Failure to do so may result in severe bodily injury or death.*

The electrical panel, and all electrical parts supplied with the FAST system are ETL (UL equivalent) certified for electrical safety. The control panel meets NEMA standards for indoor and outdoor use. It is rated for watertight and dust-tight integrity and is constructed of corrosion-resistant materials.

The standard control panel(s) supplied with FAST systems will go into alarm mode when the blower loses power, or the high pressure switch is activated.

Bio-Microbics also manufactures other control panels that can monitor UV systems and sewage pumps. This option allows a method to prevent discharge in the event of a blower failure. The optional TRACK® system (or other auto-dialers) can also be wired into the panels.

1. A dedicated 20 amp breaker is required in the building's master electrical panel. Make connections between the master panel and factory-provided blower control panel according to electrical drawing in **FIGURE 10** (pg. 30 and 31), and all applicable codes (wiring should be run through electrical conduit).

2. Wire the blower to accept the proper voltage for your specific location according to the diagrams of each blower (brand) in FIGURE 11 (pgs. 32-35) (some blowers come pre-wired to accept 220V).
3. Make connections between the blower and control panel per the electrical drawings in Fig. 10, and all applicable codes (wiring should be run through electrical conduit).
4. **FAST with SFR®:** Bio-Microbics FAST® wastewater treatment systems are now equipped with SFR® (Sequencing Fixed Reactor). This feature allows the FAST system's blower to be turned on and off at appropriate intervals. Consult your Bio-Microbics service representative when using this feature. (See FIGURE 6 below for SFR timer settings.)
5. Liquid Level switch installation procedure (this switch is a 24V device):
 - A. Identify the Common Lead and N.O. Lead on the Liquid Level Switch (See figure).
 - B. Identify the "Float" label on the printed circuit board alarm panel. (see wiring diagram fig 6)
 - C. Drill a 3/8" hole in the blower outflow pipe (See figure 8).
 - D. Connect an alarm box lead from the area labeled "Float" to the N.O. lead on the pressure switch (See figure 8 on pg. 31).
 - E. Connect the other alarm box lead from the area labeled "Float" to the Common Lead on the pressure switch (See figure 8).
 - F. Insert the pressure switch into the hole, nipple first, and glue into place. (Be careful not to cover the hole in the tip of the nipple with glue)

Run the Pressure Switch wiring back to the alarm unit separate from the blower wiring (check local regulations, some areas require that this wiring be run in electrical conduit).

TIMING MODES					BLOWER MINUTES	
DIP SW POS. (S1)					ON	OFF
5	4	3	2	1	ON	OFF
OFF	OFF	OFF	OFF	OFF	30	30
OFF	OFF	OFF	OFF	ON	60	30
OFF	OFF	OFF	ON	OFF	120	30
OFF	OFF	ON	ON	OFF	60	60
OFF	OFF	ON	ON	ON	120	60
OFF	ON	OFF	OFF	OFF	180	60
OFF	ON	OFF	OFF	ON	240	60
OFF	ON	ON	OFF	OFF	120	90
OFF	ON	ON	OFF	ON	180	90
OFF	ON	ON	ON	OFF	240	90
ON	ON	ON	ON	OFF	TEST	
ON	ON	ON	ON	ON	∞	
TEST = 15 SEC ON, 20 SEC OFF						

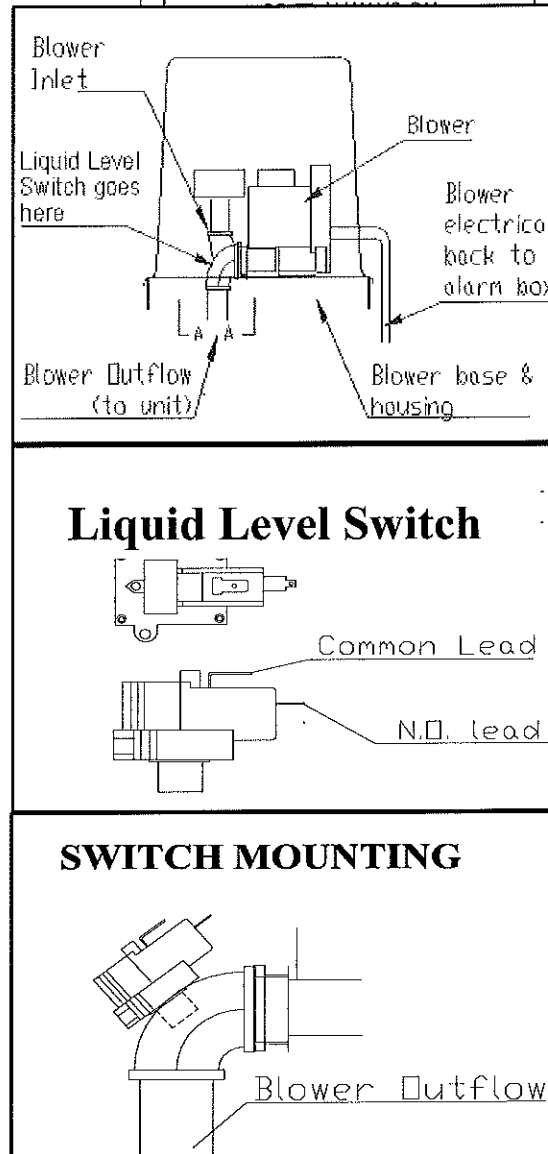

FAST® Control Panel Alarm Test

Control Panel Alarm Circuit

1. Depress the white breaker switch (rocker type switch) labeled "Blower Circuit Breaker" on the front of the panel to the "OFF" position. The red alarm light and buzzer should activate after an 8 second delay period. Red alarm light should flash.

FIGURE 8

2. While buzzer is activated, depress "Reset" switch on front of panel. Buzzer should immediately silence and remain silenced for duration of alarm event, but alarm light should continue flashing.
3. Depress the white breaker switch to the "ON" position. After an 8 second delay period the alarm light and buzzer should discontinue.
4. If the alarm behaves as described above, then the panel is set to properly detect blower current draw.

Alarm Pressure Switch (low voltage)

1. Assure the "normally open" pressure switch is wired properly at panel and the switch:
2. Create enough pressure in switch to close its contact. (Turn the blower on and restrict the air line outlet beyond the switch for at least the 8 second panel delay period.)
3. Once the alarm sounds, the pressure can be released from the switch and the panel's alarm should deactivate following the 8 second delay.
4. If the pressure switch causes alarm activation all the time or periodically while the FAST® system is properly working, then the switch may be adjusted. Check for normal turbulence in the FAST® tank before adjusting switch.
5. Adjust the pressure switch just enough that normal operating pressure does not close the switch and activate the alarm. The pressure adjustment Allen screw is opposite the switch's electrical prongs. Rotate the screw clockwise to require more pressure for alarm activation, and counter-clockwise to require less pressure.

FINAL INSTALLATION INSPECTION

It is the responsibility of the installer to fill the tank to operating level prior to backfilling the excavation. If the tank is not filled, heavy rains after backfilling could cause the tank to float and damage the surrounding grounds. Your local FAST® Systems distributor may provide installation inspection services. If you have questions, call Bio-Microbics at 1-800-753-FAST.

BEFORE THE UNIT IS BACKFILLED:

- A. Fill the tank to the normal operating level.
- B. Check for leaks in all water-tight seals.
- C. Ensure that the air line is properly installed and permanently connected to the tank and blower.
- D. Turn on the blower and observe the operation of the airlift through the observation port. A robust splash should be present.
- E. Replace the observation port lid and take note of any excessive back pressure. To determine if excessive back pressure is present, first check all access points in the entire treatment system. If air is escaping through any of these access points, review the venting configuration and make the necessary modifications. You can also remove the observation port lid and check for a gush of air. If you do feel a gush when the lid is removed, then the surface area of the venting may need to be modified.
- F. Check for proper water level over the media. The normal water line should be ~2" over the

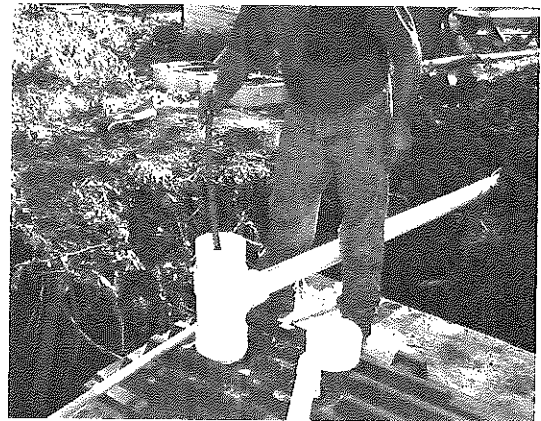
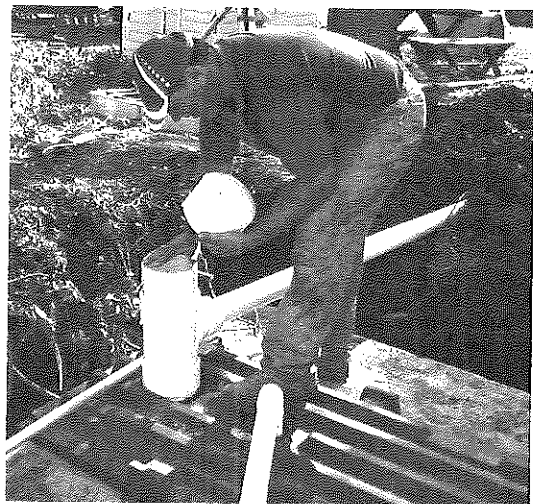

media. This level can be checked by finding a dry stick, lowering it down the observation port to the top of the media surface, and then checking the length of the wet mark on the stick.

- G. Check for proper alarm function. Turn off the blower circuit breaker and wait for the alarm to sound. If the alarm does not sound after 30 seconds, then review the electrical installation procedures.
- H. Check airlift coupler connection. It is very important that there is a permanent, glued connection between the airlift and airline. Use a telescoping mirror to double check this connection through the observation port. Additionally, the airlift coupler should be resting on the splash plate.
- I. If the unit is level, has no leaks, has even-flow dispersion of the water and no back pressure is evident, then backfill the excavation.
- J. Lastly, make sure that the unit serial number has been recorded on the front face of the control panel and the label inside the blower housing.

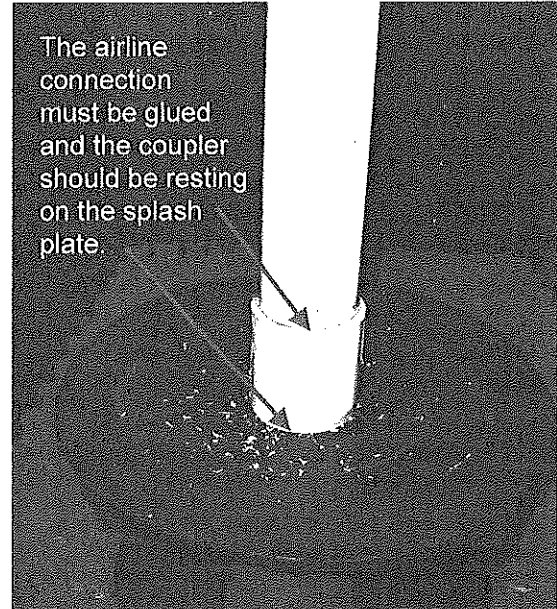

The airline connection must be glued and the coupler should be resting on the splash plate.

EVALUATION OF SYSTEM PERFORMANCE

The following basic checks in conjunction with an experienced service person's knowledge should provide a reasonable indication of the process quality.

SOUNDS	During normal operation, a uniform humming sound emanates from the system. If unusual noises are heard, it is possible the blower could need maintenance or repairs. Inspection of the treatment chamber should reveal a vigorous splashing sound within the chamber.
SMELL	The FAST SYSTEM is an aerobic system. During normal operation, the system has an earthy smell like that of a well-maintained compost pile. If other odors are noticed, the aeration process may not be operating or the system may be overloaded. Check the blower for proper operation and make sure the airlift is operating by viewing through the observation port.
SIGHT	Normally, the effluent is reasonably clear, colorless and odorless. If the effluent becomes turbid, the treatment process has developed a problem. Turbid effluent will be present with a septic odor. The same checks are made for this that are made if odors are present.

SYSTEM FAILURES

This section is a summary of the different types of failures that are the most likely to occur in the Bio-Microbics, Inc. FAST system. The consequences of, and the steps taken to prevent these failures are also explained.

Several types of failures can occur in a unit with the wide variety of components and systems present in this plant. Mechanical, electrical and process failures are the predominant concerns. Some components are subjected to more than one type of failure. Any mechanical or electrical failure will result in a process failure.

A. Mechanical Failure of the blower

The prime opportunity for failure of the blower is the internal bearings. They can fail from lack of lubricant or contaminated lubricant. Another opportunity for failure is excessive wear of the impeller resulting in lower volumes of air delivery.

1. To avoid failure, the blower selected for the unit is equipped with double sealed bearings to maximize their life.
2. Excessive wear of the impeller has been avoided by installing an inlet filter to take out any debris that could pass through the inlet screen.

B. Electrical failure of the blower

This may take place in the form of overheating or shorting out because of moisture or dirt. Both of these modes of failure have been addressed by using a TEFC motor. With the motor being totally enclosed, the problem of dirt and moisture collecting on the windings to shorten insulation life has been eliminated. The fan cooling will help the motor maintain allowable running temperature. The totally enclosed rating helps maintain the internal cleanliness of the motor.

C. Process failure from oxygen starvation of the biomass

If the biomass is starved of oxygen, the typical odors associated with anaerobic bacterial treatment will be noticed. This can be caused by insufficient air flow into the biological zone. A blockage in the air line or blower is the most probable cause.

1. The inlet screens have been located on each end of the blower housing. If one screen becomes blocked by debris, the opposite screen should still be sufficient. The suggested routine preventative maintenance calls for brushing off the screen as needed. The configuration of the inlet screens and the required maintenance will protect the unit from oxygen starvation due to insufficient air flow.
2. The blower is equipped with an inlet air filter. If this filter becomes blocked with debris it could cause oxygen starvation of the biomass. The blower inlet filter should be checked every 6 months and replaced as needed.
3. The vent pipe could also become blocked, causing insufficient air flow out of the reactor. The vent option B screen should be checked for debris, and if the pipe is blocked, a drain auger can be used to clean out the line. (Vent option A - holes in pipe should be clean of debris).
4. There is a possibility that the air line from the blower could become blocked. If this condition is suspected, disconnect the air line from the blower and check for blockage. A drain auger can be used to check the entire length of air line.

TROUBLESHOOTING GUIDE

Problem	Possible Cause	Solutions
The failure indicator light on the control panel is on, and the alarm sounds.	The air intake is blocked.	Clean intake screens on blower housing. Check air filter on blower for blockage.
	The air discharge line or vent line is blocked.	Check discharge line and vent line visually or with drain cleaning equipment for obstructions,
	The FAST system is flooded and a high water alarm was installed.	Determine cause of flooding (e.g. line obstruction, lateral field pump failure, high flows, etc.) and correct.

Problem	Possible Cause	Solutions
	The blower has failed.	Determine if blower failure was caused by an obstructed intake or discharge line.
	The blower has failed.	Investigate overheating (i.e. internal thermal overload protection), short-circuiting, or other electrical failure, and mechanical failure (i.e. bearing failure) and correct.
	The blower has failed.	Check to see whether circuit protection device for blower has tripped.
	The power cable to the blower has been damaged or is not connected properly.	Have a certified electrician check the wiring to the blower.
	The original cause for alarm has been corrected, but the flashing circuit for the indicator light has not been reset by technician.	Reset flash circuit.
The audible alarm is on.	An alarm condition has occurred. See troubleshooting items under flashing alarm indicator	Push reset button to silence alarm if provided.
Blower motor is making a loud whining or grinding noise.	Blower motor bearing has failed.	Remove blower and have blower motor serviced.
	A foreign object has entered blower housing.	Remove blower for service and check condition of air filter.
The blower is flooded.	Water has entered the blower housing	The blower should be located in an area where water does not accumulate and be located at least two feet above the treated water outlet pipe from the FAST system.
Wastewater is backing up into the home sewer piping.	There is an obstruction in the home sewer piping.	Check the piping lead to the FAST system visually or with drain cleaning equipment for an obstruction and correct.
	There is an obstruction in the discharge line from the FAST system.	Check the effluent piping and lateral field piping visually or with drain cleaning equipment for an obstruction and correct.
	The lateral field pump has failed.	Check the operation of the lateral field pump per the pump manufacture's specifications.

Problem	Possible Cause	Solutions
	The flow rate to the FAST system is too high.	Check the maximum flow rate to the FAST system to see that it is within normal limits.
	The tank requires cleaning and/or a pump out is required.	Check the sludge depth in all chambers of the tank to see if it is below required levels. If the depth is too great, have the tank pumped out and, if necessary, cleaned.
There is an unpleasant odor emanating from FAST unit.	The blower and air piping are not operating correctly.	Check the blower, vents, and air piping for proper operation.
	The system is overloaded.	Check the maximum flow rate BOD load rate to the FAST unit to see that it is within normal limits.
		Check the quality and contents of the flow into the FAST unit for any abnormal or prohibited substances.

LIMITED WARRANTY

Bio-Microbics, Inc. warrants every new FAST® system against defects in materials and workmanship for a period of two years after installation subject to the following terms and conditions, (Commercial FAST system for a period of one year after installation or eighteen months from date of shipment, whichever occurs first, subject to the following terms and conditions):

During the warranty period, if any part is defective or fails to perform as specified when operating at design conditions, and if the equipment has been installed and is being operated and maintained in accordance with the written instructions provided by Bio-Microbics, Inc., Bio-Microbics, Inc. will repair or replace at its discretion such defective parts free of charge. Defective parts must be returned by owner to Bio-Microbics, Inc.'s factory postage paid, if so requested. The cost of labor and all other expenses resulting from replacement of the defective parts and from installation of parts furnished under this warranty and regular maintenance items such as filters or bulbs shall be borne by the owner. This warranty does not cover general system misuse, aerator components which have been damaged by flooding or any components that have been disassembled by unauthorized persons, improperly installed or damaged due to altered or improper wiring or overload protection. This warranty applies only to the treatment plant and does not include any of the house wiring, plumbing, drainage, septic tank or disposal system. Bio-Microbics, Inc. reserves the right to revise, change or modify the construction and/or design of the FAST system, or any component part or parts thereof, without incurring any obligation to make such changes or modifications in present equipment. Bio-Microbics, Inc. is not responsible for consequential or incidental damages of any nature resulting from such things as, but not limited to, defect in design, material, or workmanship, or delays in delivery, replacements or repairs.

THIS WARRANTY IS IN LIEU OF ALL OTHER WARRANTIES EXPRESS OR IMPLIED. BIO-MICROBICS SPECIFICALLY DISCLAIMS ANY IMPLIED WARRANTY OF MERCHANTABILITY OR FITNESS FOR A PARTICULAR PURPOSE.

NO REPRESENTATIVE OR PERSON IS AUTHORIZED TO GIVE ANY OTHER WARRANTY OR TO ASSUME FOR BIO-MICROBICS, INC., ANY OTHER LIABILITY IN CONNECTION WITH THE SALE OF ITS PRODUCTS. Contact your local distributor for parts and service.

Electrical Drawings & Diagrams for FAST® Wastewater Treatment Systems

Pg 17—Typical FAST® Installation Components

**Pg 18—Wiring Diagram for the
110-220v Control Panel**

Pgs 19-20—Blower Wiring for Each Blower Brand

Typical FAST® Installation Components

(Actual installed components subject to design specifications)

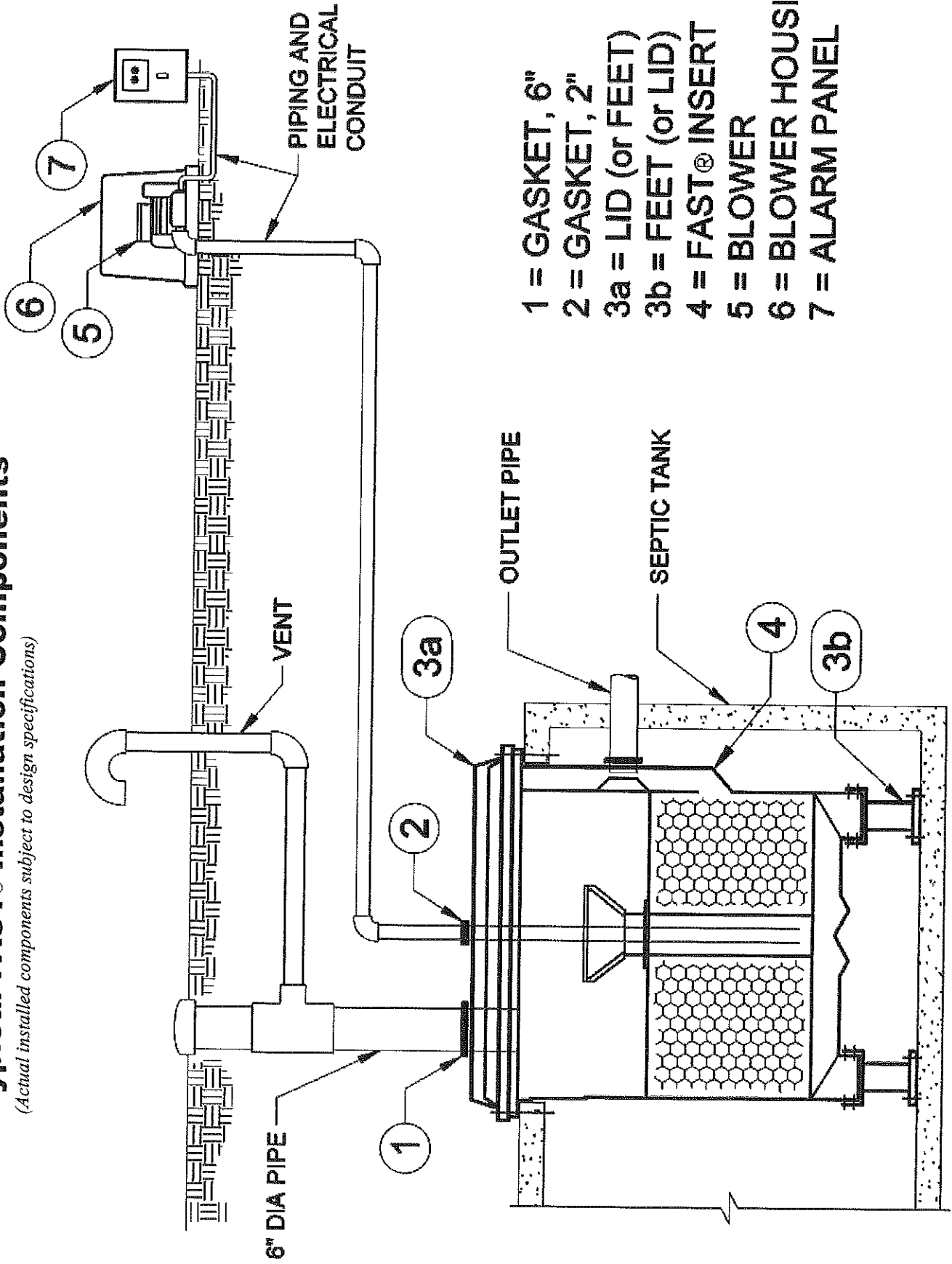

1 = GASKET, 6"

2 = GASKET, 2"

3a = LID (or FEET)

3b = FEET (or LID)

4 = FAST® INSERT

5 = BLOWER

6 = BLOWER HOUSING

7 = ALARM PANEL

110/220VAC CONTROL PANEL WIRING DIAGRAM WITH AVAILABLE OPTIONS

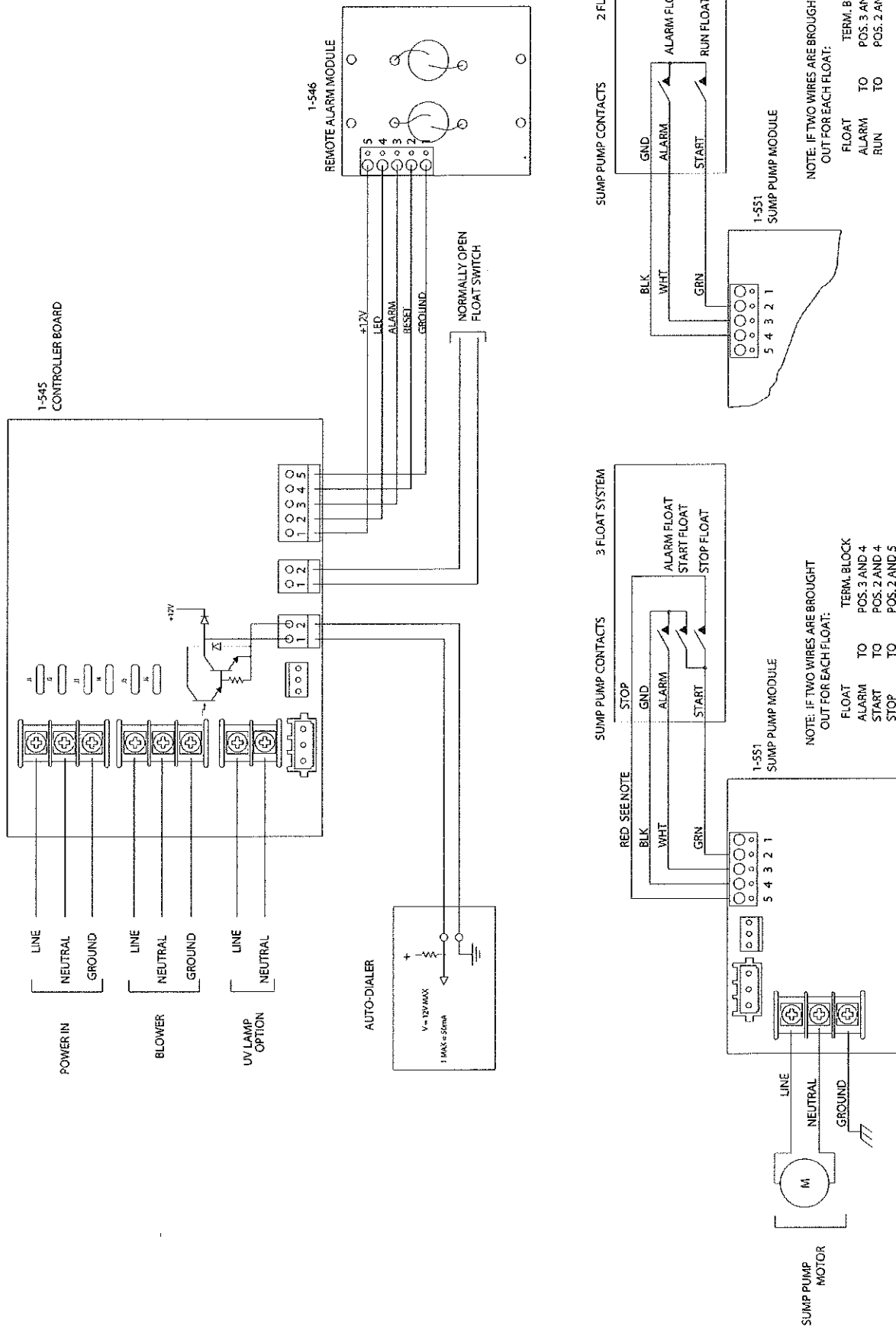

NOTE: IF TWO WIRES ARE BROUGHT OUT FOR EACH FLOAT:

TERM. BLOCK	TO	TO
ALARM	POS. 3 AND 4	POS. 3 AND 4
START	POS. 2 AND 4	POS. 2 AND 4
RUN	POS. 2 AND 4	POS. 2 AND 4

NOTE: IF TWO WIRES ARE BROUGHT OUT FOR EACH FLOAT:

TERM. BLOCK	TO	TO
ALARM	POS. 3 AND 4	POS. 3 AND 4
START	POS. 2 AND 4	POS. 2 AND 4
STOP	POS. 2 AND 5	POS. 2 AND 5

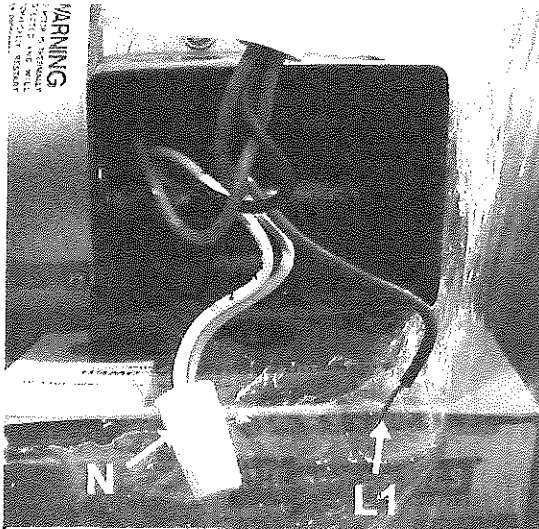

Model: GAST R2103, R4P115, R1102
 Power: 110VAC
 - L1 to P1
 - N to 2,4
 - P2,5,3 cap together

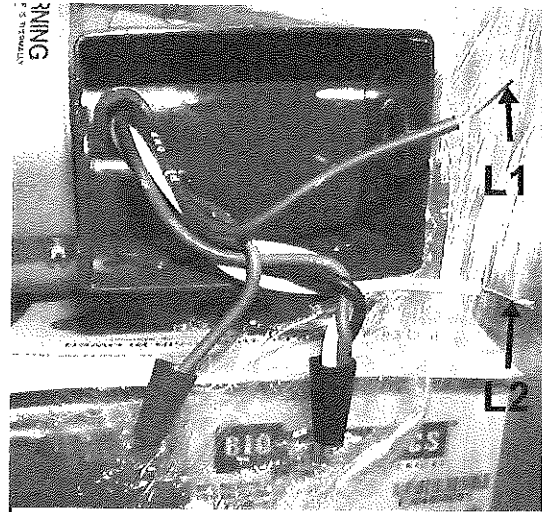

Model: GAST R2103, R4P115, R1102
 Power: 220VAC 1ø
 - L1 to P1
 - L2 to 4
 - 5, 3 and 2, cap together
 - P2 cap off

FAST® 110VAC “CSI” PANEL W/ 3 FRONT LIGHTS

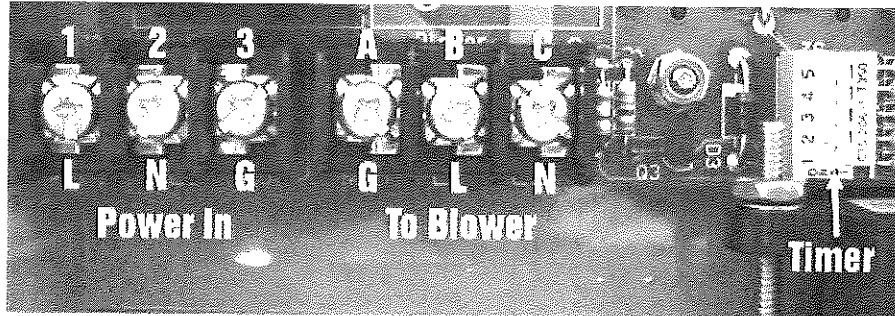

FAST® 110VAC “AMI” PANEL W/ 2 FRONT LIGHTS

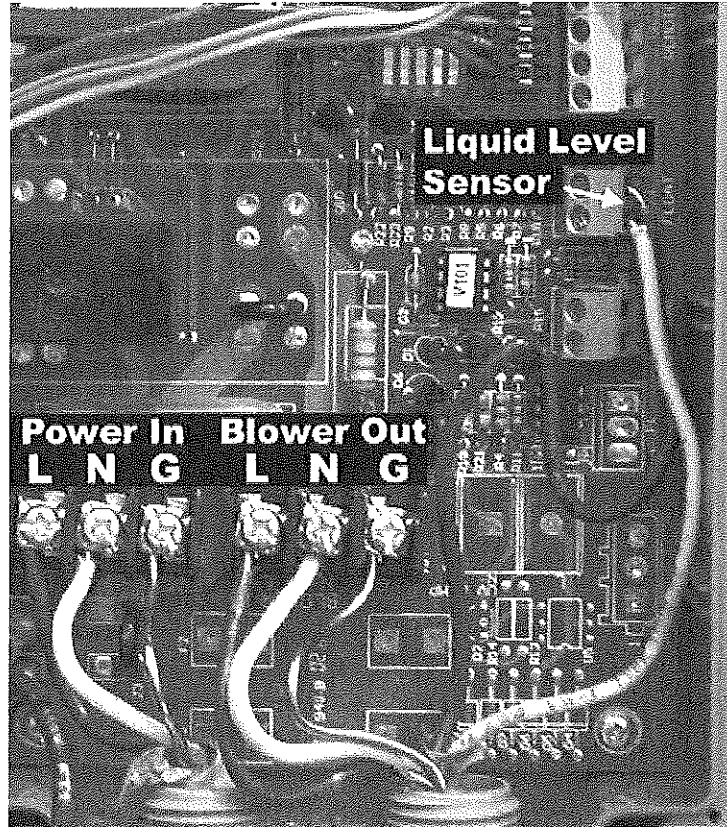

FAST® 220VAC 1Ø PANEL

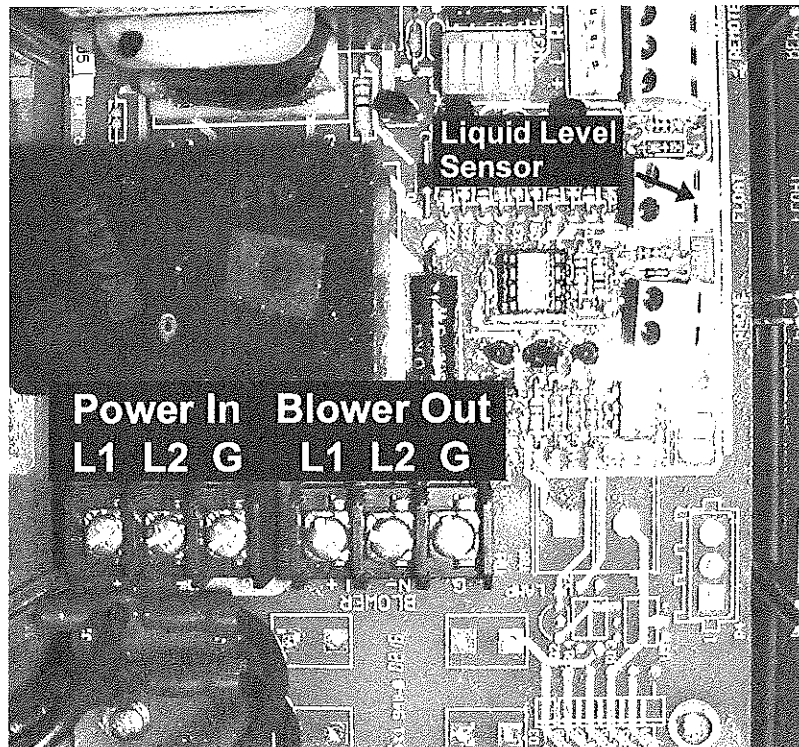

INDEX

- Aerobic, 12
- Air supply line, 4, 7, 8, 10
- Anaerobic, 4, 13
- Anchor bolt, 2, 7
- Backfill, 12
- Biomass, 4-5, 13
- Blower, 2, 4, 8-13
- Blower assembly, 2, 9-10
- Blower location, 3, 9
- Burial depth, 3, 5
- Circuit breaker, 10
- Detergents, 2
- Effluent, 2-3, 5, 7, 12, 14
- Electrical conduit, 9-12
- Electrical failure, 12-13
- Electrical requirements, 16
- Failures, 12
- Flocculation, 4
- Influent, 2-3
- Inspection, 3, 11-12
- Joint sealant compound, 2, 6-7
- Leaks, 16
- Limited-use substances, 18
- Location, 6
- Materials required, 4
- Mechanical failure, 12-13
- Media, 4, 5, 7
- Observation port, 6, 8-9, 12
- Oxygen starvation, 13
- pH, 4
- Pipe joint lubricant, 2
- Plastic, 18
- Preventative maintenance, 20
- Primary treatment, 4
- Process description, 16
- Process failure, 12-13
- Pump out, 4, 15
- Reactor, 11, 13
- Replacement parts, 15
- Secondary treatment, 4
- Septic tank inlet, 3-4
- Septic tank outlet, 3, 7, 14
- SFR, 11
- Sight, 12
- Slope, 3
- Sludge depth, 15
- Smell, 12
- Sounds, 12
- Suspended solids, 4
- Troubleshooting, 13
- Vent, 2, 3, 8-9, 12, 13, 15
- Warnings, 2-3, 6, 9-10
- Warranty, 15