

150 mm TOP CONCRETE BARRIER TO STANDARD CONCRETE BARRIER TRANSITION SECTION

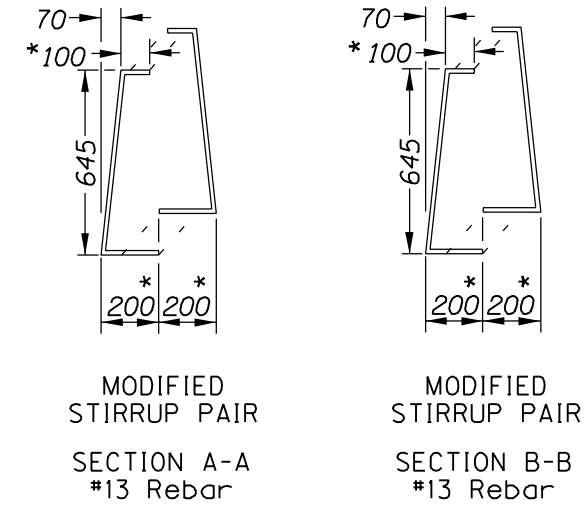

* Dimension Variable Through Transition Section.

NOTE:
 Connection Details This End Shall Be As Detailed For The Shoulder And/Or Median Barrier Being Used.

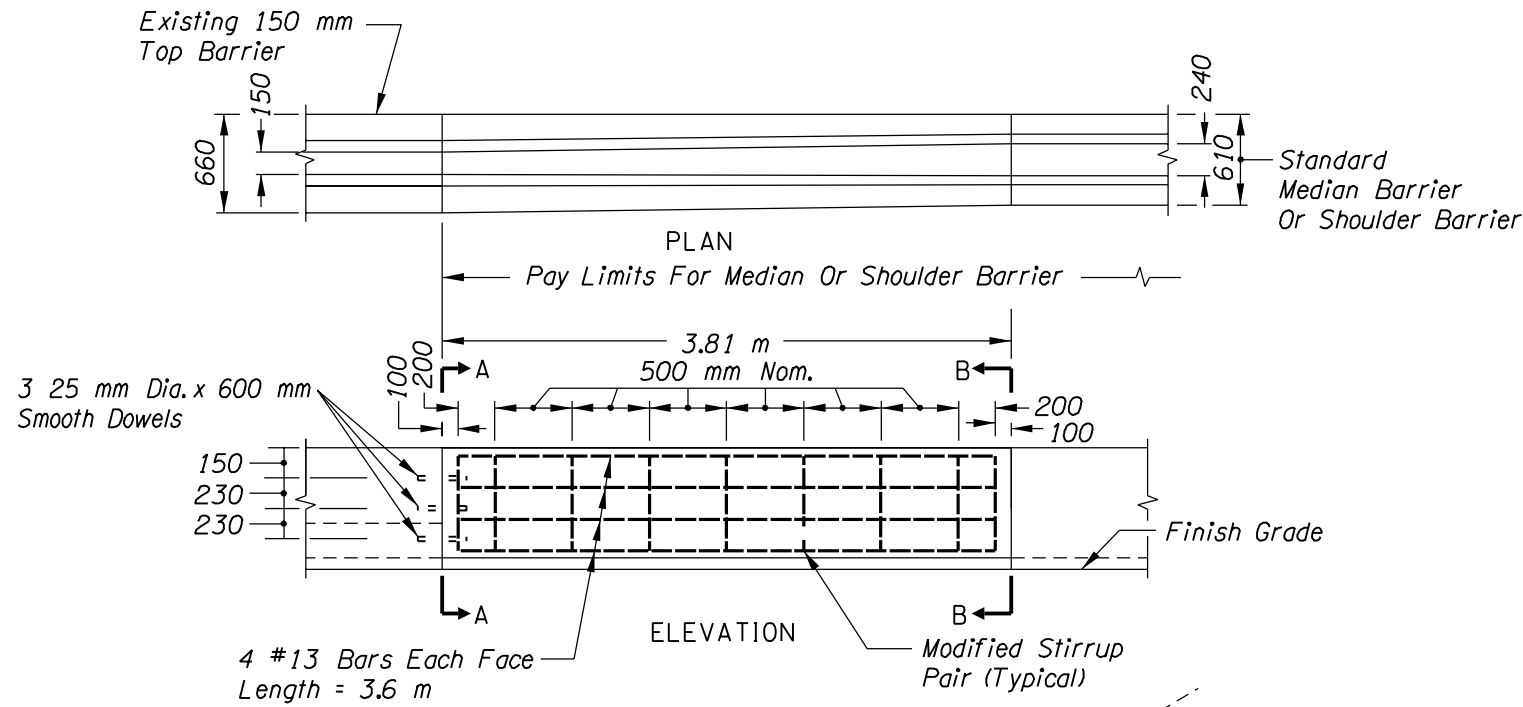
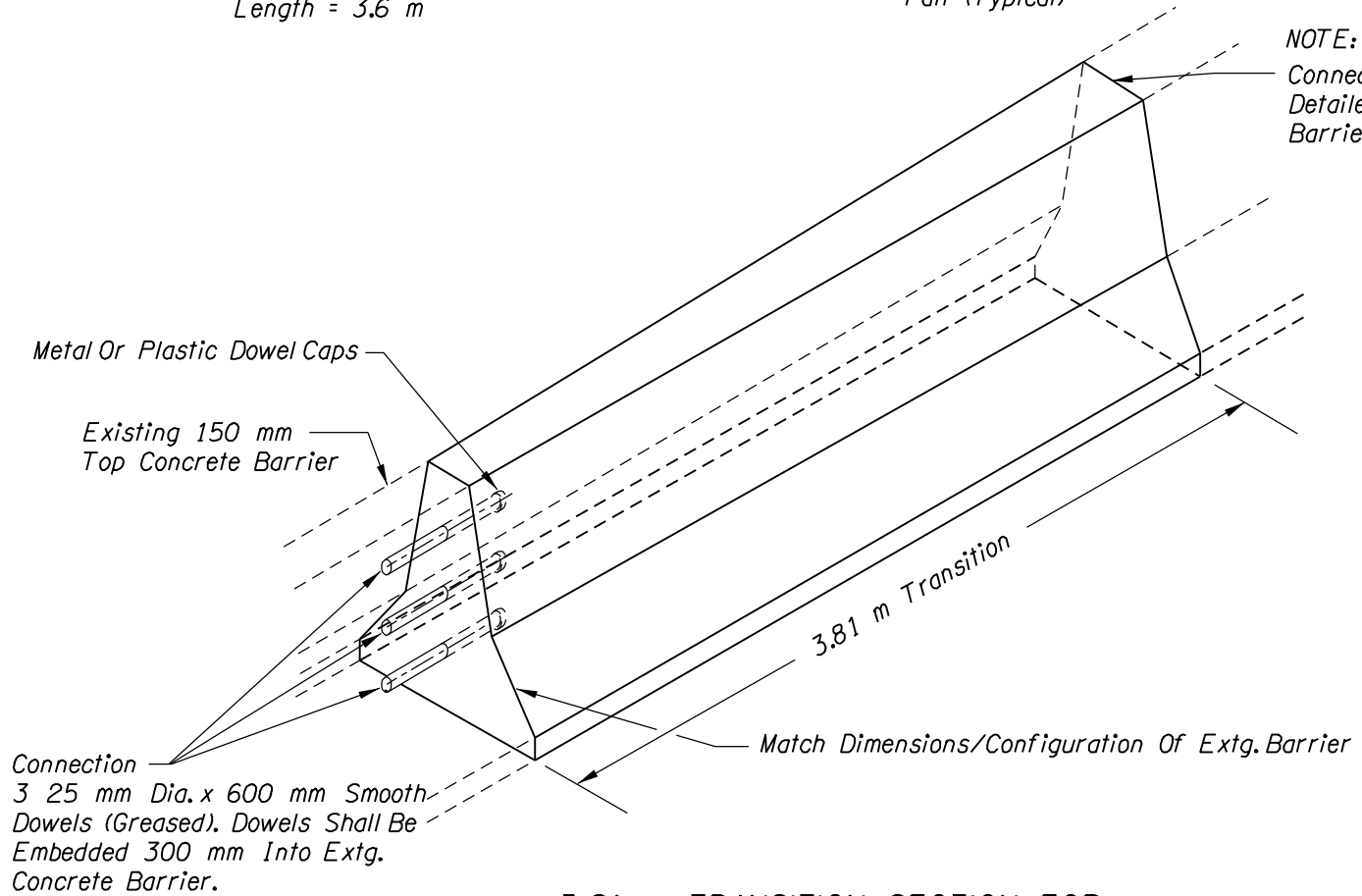

GENERAL NOTES:

1. See Drg. No. RD500 For Details Not Shown.
2. All Reinforcing Steel Shall Conform To ASTM A706M Or AASHTO M31M (ASTM A615M) Grade 420
3. All Metal Reinforcement Shall Be 40 mm (Min.) Clear Of Nearest Face Of Concrete, Unless Otherwise Shown.

• All dimensions are in mm unless otherwise noted.

**3.81 m TRANSITION SECTION FOR
 MEDIAN BARRIER OR SHOULDER BARRIER (CAST IN PLACE)**

	OREGON DEPARTMENT OF TRANSPORTATION
	SHEET NO.

ne7360ab/usr/mdet/detail105.dgn 5-14-97

DET 105